

*colección | collection*

**2018**

**GRESPANIA**

*colección | collection*

**2018**

**GRESPANIA**

Grespania es una empresa internacional dedicada a la fabricación y comercialización de productos cerámicos innovadores en cuanto a propiedades y diseño. La inversión constante, la incorporación continua de los últimos avances en fabricación y diseño y el máximo respeto por el medio ambiente han consolidado su liderazgo mundial a lo largo de los últimos 40 años.

Grespania dispone en la actualidad de 3 fábricas que incorporan las últimas tecnologías y los procesos más avanzados para la producción de pavimentos de gres porcelánico, de revestimientos de pasta blanca y de laminado porcelánico de gran formato, de hasta 120x360 cm y de reducidos espesores. Además de sus centros productivos en España, la empresa cuenta con filiales en Francia, Italia, Holanda, Polonia y Reino Unido.

Gracias a esta combinación de centros productivos avanzados con una red de filiales consistente, Grespania es capaz de ofrecer productos de calidad en todo el mundo.

Hoy, 40 años después, la historia de Grespania sigue mirando al futuro.

Grespania is an international ceramic manufacturing company, producing collections which boast both innovative technical properties as well as innovative cutting edge designs. A combination of ongoing investment in further improving the manufacturing process, continual adaption to latest advances in design, and a permanent concern for the 'good of the environment' have all helped 'stamp' the Grespania brand as a global market leader for the past 40 years.

The possibilities within the Grespania product range are endless: from ideas for those seeking a touch of personality and unique style for their homes, to technical solutions for professionals involved in the most exciting building projects.

Grespania has three factories all equipped with state-of-the-art technology and the most advanced processes for the production of porcelain floor tiles, white body wall tiles and large format porcelain slabs up to 120x360 in size in varying thicknesses.

In addition to its production facilities Grespania has two service centres in Santiago de Compostela and Granada in Spain. The company also has 5 subsidiaries companies serving as distribution hubs in strategic European countries: France, Italy, the Netherlands, Poland and the UK.

Today, 40 years on, Grespania continues to build and look towards the future.

Grespania è un'azienda internazionale che si dedica alla produzione e alla vendita di prodotti in ceramica, innovativi in termini di proprietà e di design. Gli investimenti costanti, l'inserimento continuo degli accorgimenti tecnici più avanzati nella progettazione e nella produzione, nonché il massimo rispetto nei confronti dell'ambiente ne hanno consolidato la leadership nel mondo nel corso degli ultimi 40 anni.

La gamma di prodotti di Grespania non ha limiti: dagli spunti per chi cerca un tocco di personalità e di stile da donare alla propria casa alle soluzioni tecniche per gli operatori più esigenti del settore.

Grespania dispone attualmente di tre stabilimenti che si avvalgono delle tecnologie e dei processi più avanzati per la produzione di pavimenti in gres porcellanato, di rivestimenti in pasta bianca e di gres porcellanato laminato di grande formato, fino a 120x360 cm e con spessore ridotto. Oltre ai centri produttivi in Spagna, l'azienda possiede filiali in Francia, Italia, Olanda, Polonia e Regno Unito e due centri logistici a Santiago de Compostela e a Granada. Grazie a questa struttura formata dai centri produttivi avanzati e dalla rete consistente di filiali, Grespania è in grado di offrire prodotti di qualità in tutto il mondo.

Oggi, dopo 40 anni, la storia di Grespania continua a puntare sul futuro.

Grespania to międzynarodowa firma specjalizująca się w produkcji i sprzedaży produktów ceramicznych, innowacyjnych zarówno pod względem technologii jak i wzornictwa. 40 lat ciągłych inwestycji, wdrażanie nowych technologii produkcji, innowacyjne wzornictwo oraz szczególna dbałość i poszanowanie środowiska umocniły naszą pozycję lidera na skalę światową.

Szeroka gama produktów Grespanii nie zna ograniczeń, począwszy od idei dla tych, którzy szukają oryginalności i własnego stylu, aż po rozwiązania techniczne dla najbardziej wymagających specjalistów.

Obecnie firma posiada trzy fabryki produkcyjne stosujące najnowocześniejsze rozwiązania i procedury w technologii produkcji płytek podłogowych z gresu porcelanowego oraz płytek ściennych z białej masy a także porcelanowe płyty wielkoformatowe aż do 120x360 wielkości, występujące w różnych grubościach. Poza fabrykami znajdującymi się w Hiszpanii, firma posiada również oddziały we Francji, Włoszech, Holandii, Polsce, Wielkiej Brytanii oraz dwa centra serwisowe w Santiago de Compostela i Granadzie. Połączenie nowoczesnych zakładów i sieci oddziałów gwarantuje możliwość oferowania produktów doskonałej jakości na całym świecie.

Obecnie, po prawie 40 latach od powstania firmy, Grespania nadal spogląda w przyszłość.



ESPAÑA - Castellón



ESPAÑA - Nules



ESPAÑA - Moncofar



UNITED KINGDOM



ITALIA



NEDERLANDS



POLSKA



FRANCE

Grespania ist ein internationales Unternehmen, das der Herstellung und dem Vertrieb von eigenschafts- und designmäßig innovativen Keramikprodukten gewidmet ist. Die ständige Investition, die kontinuierliche Übernahme der modernsten Herstellungs- und Designfortschritte sowie maximaler Umweltschutz haben in den vergangenen 40 Jahren weltweit die Führungsposition des Unternehmens gefestigt.

Das Produktsortiment von Grespania kennt keine Grenzen: Angefangen von Ideen für alle, die für ihre Wohnbereiche einen persönlichen Touch und eigenen Stil suchen, bis hin zu technischen Lösungen für anspruchsvolle Fachleute im Bauwesen.

Grespania verfügt derzeit über drei Produktionsstätten, in denen die jüngsten Technologien und fortschrittlichsten Verfahren für die Herstellung von Bodenfliesen aus Feinsteinzeug, Wandfliesen aus Weißscherben und Feinsteinzeug Laminat im Grossformat, bis zu 120x360 cm und reduzierten Stärken zur Anwendung kommen. Neben den Produktionszentren in Spanien besitzt das Unternehmen auch Niederlassungen in Frankreich, Italien, den Niederlanden, Polen und Großbritannien sowie zwei Serviceeinrichtungen in Santiago de Compostela und Granada. Dank dieser Kombination aus fortschrittlichen Produktionszentren mit einem konsistenten Netz an Filialen ist Grespania in der Lage, weltweit erstklassige Produkte anzubieten.

Heute, nach beinahe 40 Jahren, blickt man bei Grespania nach wie vor in die Zukunft.

Grespania est une société internationale se consacrant à la fabrication et à la commercialisation de produits céramiques innovants en termes de fonctionnalités et de design. L'investissement constant, l'intégration continue des dernières avancées en matière de fabrication et de design et le respect maximum de l'environnement ont consolidé son leadership mondial tout au long des 40 dernières années.

La gamme de produits de Grespania ne connaît pas de limites, des idées pour ceux qui souhaitent une touche de personnalité et de style propres chez eux, aux solutions techniques pour les professionnels du bâtiment les plus exigeants.

Grespania dispose actuellement de trois usines qui utilisent les dernières technologies et les procédés les plus avancés pour la production de carreaux de sol en grès cérame et de carreaux de mur en pâte blanche, ainsi que des carreaux en grès cérame laminés de très faible épaisseur et mesurants jusqu'à 120cmx360cm. En plus de ses centres de production en Espagne, la société dispose de filiales en France, Italie, Hollande, Pologne et Royaume-Uni, ainsi que de deux centres de service à Saint Jacques de Compostelle et à Grenade. Grâce à la combinaison des centres de production avec un solide réseau de filiales, Grespania est capable d'offrir des produits de qualité dans le monde entier.

À ce jour, 40 ans après, l'histoire de Grespania est toujours tournée vers le futur.

Grespania is een internationaal bedrijf dat zich wijdt aan de vervaardiging en het op de markt brengen van keramische producten die zeer innoverend zijn qua eigenschappen en ontwerp. De constante investeringen, het voortdurend toevoegen van de laatste vooruitgang op het gebied van productie en ontwerp met een maximale milieuvriendelijkheid hebben ervoor gezorgd dat het bedrijf in de afgelopen 40 jaar een leidende positie in heeft genomen op de wereldmarkt.

Het assortiment van Grespania kent geen grenzen: van ideeën voor diegenen die hun woning een persoonlijke touch en eigen stijl willen geven tot technische oplossingen voor de meest veeleisende professionals uit de bouwsector.

Grespania beschikt op dit moment over drie fabrieken die uitgerust zijn met de laatste technologie en de meest geavanceerde processen voor het vervaardigen van porseleinen vloertegels, witte scherf wandtegels en grootformaat, porseleinen platen in verschillende diktes.

Naast de productiecentra in Spanje, bezit het bedrijf filialen in Frankrijk, Italië, Nederland, Polen en het Verenigd Koninkrijk en twee servicecentra in Santiago de Compostela en Granada. Deze combinatie van geavanceerde productiecentra met een consistent netwerk aan filialen maakt dat Grespania in staat is kwaliteitsproducten te leveren over de hele wereld.

Nu, 40 jaar later, kijkt Grespania nog steeds naar de toekomst.

Grespania — это международная компания, которая занимается производством и коммерческой реализацией керамических продуктов с инновационными характеристиками и дизайном. Постоянные инвестиции и внедрение последних достижений в производство и дизайн, а также максимально бережное отношение к окружающей среде — все это в течение 40 лет существования компании сделало ее признанным мировым лидером. Гамма продукции Grespania поистине безгранична: здесь найдется все, начиная от идей для тех, кто желает придать своему жилью персонализированные штрихи и собственный стиль, до технических решений для самых требовательных профессионалов строительства.

В настоящий момент Grespania имеет три фабрики, включающие последние технологии и самые передовые процессы производства напольных покрытий из керамогранита и ультратонкого керамогранита больших форматов размерами до 120 x 360 см, а также настенной керамической плитки из белой глины. Кроме производственных центров в Испании, компания располагает филиалами во Франции, Италии, Голландии, Польше и Великобритании, а также двумя сервисными центрами в Сантьяго-де-Компостела и Гранаде. Благодаря такой комбинации передовых производственных центров с устойчивой сетью филиалов Grespania оказывается способной предлагать качественные продукты по всему миру. Сегодня, почти 40 лет спустя, Grespania продолжает уверенно смотреть в будущее.



#### ¿QUÉ ES H&CTILES?

H&CTILES es la aplicación en el campo de la cerámica de la tecnología Hydrotect®, un recubrimiento de Dióxido de Titanio que permite reducir la contaminación ambiental y proporciona al material cerámico propiedades autolimpiables, bactericidas y de eliminación de malos olores.

La exposición del Dióxido de Titanio a la radiación ultravioleta produce una reacción fotocatalítica que genera oxígeno activo y descompone la suciedad en partículas más pequeñas y menos adhesivas. Gracias a las propiedades hidrófilas de H&CTILES, el agua se expande sobre la superficie de forma uniforme, facilitando de esta forma el arrastre y la eliminación de las partículas de suciedad.

El producto aplicado se convierte en parte integrante del mismo material cerámico, ofreciendo un efecto duradero en el tiempo, autoregenerable, todo ello sin alterar las propiedades técnicas y estéticas propias de la cerámica.

#### WHAT IS H&CTILES?

H&CTILES is the ceramic application using Hydrotect® technology, in which a titanium dioxide coating reduces pollution and provides ceramics with self-cleaning, antibacterial and odour removal properties.

The exposure of titanium dioxide to ultraviolet radiation produces a photo-catalytic reaction that generates active oxygen and breaks down dirt into smaller and less adhesive particles. Due to the hydrophilic properties of H&CTILES, water spreads over the surface uniformly, thereby facilitating drag and the removal of dirt particles.

The applied product becomes an integral part of the same ceramic material, providing a lasting effect over time that is self-regenerating, all without altering the technical properties and the aesthetics of the ceramics.

#### WAT IS H&CTILES?

H&CTILES is de toepassing van Hydrotect® technologie op het gebied van de keramiek. Het betreft hier een Titaandioxide coating, waarmee milieuvervuiling teruggebracht wordt, die het keramische materiaal zelfreinigende, bacteriedodende eigenschappen geeft en die slechte geuren verwijdert.

Wanneer titaandioxide blootgesteld wordt aan ultraviolette straling ontstaat er een fotokatalytische reactie, die actieve zuurstof produceert, waarmee vuil afgebroken wordt in kleinere en minder sterk klevende deeltjes. Vanwege de hydrofiele eigenschappen van H&CTILES verspreidt het water zich gelijkmatig over het oppervlak, zodat alle vuildeeltjes door het water meegevoerd en verwijderd worden.

Het aangebrachte product wordt een geïntegreerd deel van het keramische materiaal en geeft het zo een duurzame, zelf regenererbare werking. Dit alles zonder de technische en esthetische eigenschappen van de keramiek te wijzigen.

#### QU'EST CE QUE H&CTILES?

H&CTILES est l'application dans le domaine de la céramique, de la Technologie Hydrotect®, une couche en Dioxyde de Titane permettant de réduire la pollution de l'environnement, et procurant aux matériaux de céramique des propriétés autonettoyantes, bactéricides et d'élimination des mauvaises odeurs. L'exposition de Dioxyde de Titane aux rayons ultra-violet, produit une réaction photocatalytique qui génère de l'oxygène actif et décompose la saleté en particules fines, moins adhérentes. Grâce aux propriétés hydrophiles de H&CTILES, l'eau se répand sur la surface de manière uniforme, facilitant l'écoulement et l'élimination des particules de salissures.

Le produit appliqué devient partie intégrante de la céramique, offrant un effet durable dans le temps, auto-régénérable, tout cela sans altérer les propriétés techniques et esthétiques de la céramique.



**AUTOLIMPIABLE**  
SELF CLEANING  
AUTONETTOYANT  
AUTOPULENTE  
SELBSTREINIGEND  
WŁAŚCIWOŚCI SAMOCZYSZCZĄCE  
ZELFREINIGEND  
САМООЧИЩАЕТСЯ



**PURIFICA EL AIRE**  
AIR PURIFYING  
PURIFIANT DE L'AIR  
PURIFICA L'ARIA  
LFTREINIGEND  
OCZYSZCZANIE POWIETRZA  
LUCHTZUIVEREND  
ОЧИЩАЕТ ВОЗДУХ



**ANTIBACTERIAS Y OLORES**  
ANTI-BACTERIA AND ODOUR REMOVING  
ANTIBACTÉRIEN ET ANTI-ODEUR  
COMBATTE I BATTERI E I CATTIVI ODORI  
ANTIBAKTERIELL UND GERUCHSMINDERND  
DZIAŁANIE ANTYBAKTERYJNE, NIWELOWANIE BRZYDKICH ZAPACHÓW  
ANTIBACTERIEEL EN ANTI GEUR  
АНТИБАКТЕРИАЛЬНОЕ И УСТРАНЯЕТ НЕПРИЯТНЫЕ ЗАПАХИ

#### COS'È H&CTILES?

H&CTILES è l'applicazione nel campo della ceramica della tecnologia Hydrotect®, un rivestimento al biossido di titanio che consente di ridurre l'inquinamento ambientale e che conferisce al materiale ceramico proprietà autopulenti, battericide e di eliminazione dei cattivi odori.

L'esposizione del biossido di titanio alla radiazione ultravioletta provoca una reazione fotocatalitica che genera ossigeno attivo e decompone lo sporco in particelle più piccole e meno aderenti. Grazie alle proprietà idrofile di H&CTILES, l'acqua si distribuisce uniformemente sulla superficie, agevolando in tal modo la rimozione delle particelle di sporco.

Il prodotto applicato diventa parte integrante del materiale ceramico, offrendo un effetto duraturo nel tempo, autorigenerabile, il tutto senza alterare le proprietà tecniche ed estetiche tipiche della ceramica.

#### ЧТО ТАКОЕ H&CTILES?

H&CTILES — это применение технологии Hydrotect® в сфере керамической плитки. Технология Hydrotect® состоит в покрытии диоксидом титана, которое позволяет сократить загрязнение окружающей среды и придает керамическому материалу такие свойства, как самоочищение, бактерицидность и удаление неприятных запахов.

Подвергаясь ультрафиолетовому облучению, диоксид титана вызывает photocatalyticкую реакцию, которая порождает активный кислород и разлагает загрязнения на более мелкие и менее прилипающие частицы. Благодаря гидрофильным свойствам H&CTILES вода распространяется по поверхности равномерно, смывая частицы грязи. Применяемое средство становится неотъемлемой частью самого керамического материала, обеспечивая длительный и самовосстанавливаемый эффект, причем все это без нарушения собственных технических и эстетических свойств керамической плитки.

#### WAS IST H&CTILES?

H&CTILES ist die Anwendung der Technologie Hydrotect® auf den Bereich der Keramik. Dabei handelt es sich um eine Beschichtung aus Titandioxid, mit der die Umweltverschmutzung reduziert werden kann, das Keramikmaterial selbstreinigende und bakterizide Eigenschaften erhält und schlechte Gerüche entfernt werden.

Wenn Titandioxid ultravioletter Strahlung ausgesetzt wird, entsteht eine photokatalytische Reaktion, die Aktivsauerstoff erzeugt und den Schmutz in kleinere und weniger stark haftende Partikel zersetzt. Aufgrund der hydrophilen Eigenschaften von H&CTILES breitet sich das Wasser gleichmäßig auf der Fläche aus, sodass die Schmutzpartikel mitgespült und entfernt werden.

Das aufgetragene Produkt wird zu einem integrierenden Bestandteil des Keramikmaterials selbst und verleiht ihm eine dauerhafte, von selbst regenerierbare Wirkung, ohne dabei die technischen und ästhetischen Eigenschaften der Keramik zu verändern.

#### CZYM JEST H&CTILES?

H&C TILES to wynik zastosowania w ceramice technologii Hydrotect®. Jest to szkliwo zawierające dwutlenek tytanu, które zmniejsza zanieczyszczenie środowiska, a pokryte nim płytki posiadają właściwości samoczyszczące, bakteriobójcze i niwelują brzydkie zapachy.

Wystawienie dwutlenku tytanu na działanie promieniowania ultrafioletowego wywołuje reakcję fotokataliczną, powodującą wydzielanie się aktywnego tlenu oraz rozkład brudu na mniejsze i mniej przyczepne cząstki. Dzięki cechom hydrofilnym H&C TILES, woda rozprzodza się równomiernie po powierzchni, ułatwiając tym samym usuwanie cząstek brudu.

Produkt ten stosowany na płytce staje się jej integralną częścią, przez co jest trwały i działa samoistnie, nie zmieniając jednocześnie właściwości technicznych i estetycznych płytki ceramicznej.



APPLICATIONS ET ATOUTS / APPLICAZIONI E VANTAGGI / ANWENDUNGEN UND VORTEILE / ZASTOSOWANIE I ZALETY / TOEPASSINGEN EN VOORDELEN / ПРИМЕНЕНИЯ И ПРЕИМУЩЕСТВА

INTERIORES

INTERIORS / INTÉRIEURS / INTERNI / INNENBEREICHE / WNĘTRZA / BINNEN / ВНУТРЕННИЕ ПОМЕЩЕНИЯ



ELIMINA LAS BACTERIAS Y OLORES, FACILITA LA LIMPIEZA

Centros sanitarios / Centros productivos con necesidades de atmósferas estériles y de tecnología avanzada / Cocinas industriales, centros de catering, establecimientos de alimentación / Baños públicos, vestuarios / Piscinas, spa, centros wellness, deportivos y recreativos / Uso privado (baños, cocinas...)

REMOVES BACTERIA AND SMELLS, EASES CLEANING

Health Centres / Production centres with sterile atmospheres and those for high technology / Industrial kitchens, catering centres, food preparation centres / Public baths, changing rooms / Swimming pools, wellness centres and spas, sports and recreational centres / Private use (Bathrooms, kitchens...)

ELIMINIERT BAKTERIEN UND GERÜCHE, ERLEICHTERT DIE REINIGUNG.

Gesundheitszentren / Produktionsstätten, in denen sterile Luftverhältnisse und fortschrittliche Technologie erforderlich ist / Schwimmbäder, Wellness- und Spa-Anlagen, Sport- und Freizeiteinrichtungen usw./ Gewerbliche Küchen, Catering-Einrichtungen, Lebensmittelgeschäfte usw. / Öffentliche Bäder und Toiletten, Umkleidekabinen / Privatnutzung (Bäder, Küchen)

ÉLIMINE LES BACTÉRIES ET ODEURS, FACILITE LE NETTOYAGE.

Centres de Santé / Centres productifs à atmosphère stérile, et de Haute Technologie / Piscines, centres de bien-être et SPA, centres sportifs et récréatifs / Cuisines industrielles, centres de ravitaillement, établissements alimentaires / Bains publics, vestiaires / Usage privé (salle de bain, cuisine)

ELIMINA I BATTERI E I CATTIVI ODORI, AGEVOLA LA PULIZIA

Centri sanitari / Centri produttivi richiedenti atmosfere sterili e tecnologia avanzata / Piscine, centri wellness e SPA, centri sportivi e ricreativi / Cucine industriali, centri di catering, lavorazione di prodotti alimentari / Bagni pubblici, spogliatoi / Uso privato (bagni, cucine)

ZABIJA BAKTERIE, NIWELUJE BRZYDKIE ZAPACHY, UŁATWIA CZYSZCZENIE.

ośrodki zdrowia / ośrodki produkcyjne o zaawansowanej technologii i sterylnych warunkach / baseny, centra odnowy biologicznej, SPA, ośrodki sportowe i rekreacyjne, itp / kuchnie przemysłowe, centra cateringowe i inne, gdzie przetwarzane są produkty spożywcze / publiczne toalety, szatnie / pomieszczenia prywatne (łazienki, kuchnie)

VERWIJDELT BACTERIËN EN GEUREN, MAKKELIJKER TE REINIGEN.

gezondheidscentra / productiecentra waar steriele lucht en geavanceerde technologie een must zijn / zwembaden, wellness- en spacentra, sport- en recreatiecentra / industriële keukens, cateringcentra, eetgelegenheden / openbare toiletten, kleedkamers / privégebruik (badkamers, keukens)

УСТРАНЯЕТ БАКТЕРИИ И НЕПРИЯТНЫЕ ЗАПАХИ, ОБЛЕГЧАЕТ ЧИСТКУ.

Медицинские центры / Производственные центры, для которых необходима стерильная атмосфера и передовая технология / Бассейны, центры велнеса и спа, спортивные и досуговые центры и т. П. / Индустриальные кухни, центры кейтеринга, заведения общественного питания и т. П. / Общественные бани, раздевалки / Применение в частных домах (ванные комнаты, кухни)

EXTERIORES

EXTERIORS / EXTÉRIEURS / ESTERNI / AUSSENBEREICHE / NA ZEWNAŹRZ / BUITEN / НАРУЖНЫЕ ПРОСТРАНСТВА

PURIFICA EL AIRE, ELIMINA EL NOX, ES AUTOLIMPIABLE

Fachadas

PURIFIES THE AIR, ELIMINATES NOX, SELF CLEANING

Facades



LUFTREINIGUNG, ELIMINIEREN VON NOX-EMISSIONEN, SELBSTREINIGUNG.

Fassaden

PURIFIE L'AIR, ÉLIMINE LE NOX, EST AUTONETTOYANT.

Façades

PURIFICA L'ARIA, ELIMINA IL NOX, È AUTOPULENTE

Facciate

OCZYSZCZA POWIETRZE, USUWA TLENKI AZOTU, SAMOCZYSZCZĄCE SIĘ POWIERZCHNIE.

Elewacje budynków

ZUIVERT DE LUCHT, VERWIJDELT NOX, ZELFREINIGEND.

Gevels

ОЧИЩАЕТ ВОЗДУХ, УСТРАНЯЕТ ОКСИДЫ АЗОТА, САМООЧИЩАЕТСЯ

Фасады

H&C TILES INDEX

PORCELÁNICO / PORCELAIN TILES

AMAZONIA NATURAL 068  
METEOR 044

REVESTIMIENTO / WALL TILES

FINLANDIA BLANCO 290  
SIBERIA BLANCO 290  
MONTBLANC BLANCO 258  
FRESH BLANCO  
ICE BLANCO

El resto de series y modelos pueden ser suministradas con este tratamiento con una exigencia de cantidad mínima. Rogamos consulten a nuestro departamento comercial.

The others ranges can be treated into H&C Tiles although minimum quantities will be required. Please contact our sales department.

Die restlichen Serien und Modelle können mit dieser Anwendung unter Einhaltung einer Mindestbestellmenge geliefert werden. Wir bitten unsere Verkaufsabteilung zu fragen.

Les restes des séries et modèles peuvent être proposés avec ce procédé à condition d'atteindre la quantité minimum exigée. Veuillez consulter notre service commercial.

Le altre serie possono essere sottoposte a questo trattamento a condizione che ci sia una quantitativo minimo. Per ulteriori chiarimenti rivolgetevi al nostro ufficio commerciale.

Technologia H&C Tiles może zostać zastosowana również do innych kolekcji, wymogiem jest złożenie zamówienia na odpowiednią ilość płytek. W tej sprawie, prosimy o kontakt z naszym działem handlowym.

De andere collecties kunnen op verzoek behandeld worden tot H&C Tiles, hoewel hiervoor een minimale hoeveelheid gevraagd zal worden. Neem gerust contact op met onze verkoopafdeling voor meer informatie.

Остальные серии и модели могут быть обработаны H&C TILES при заказе с определенным минимальным объемом. Необходима предварительная консультация с нашим коммерческим отделом.

\* La Tecnología Hydrotect se encuentra actualmente en proceso de registro de acuerdo al Reglamento Europeo de Biocidas nº 528/2012.

\* Hydrotect technology is currently undergoing registration for the European Biocides Standard nº 528/2012.

\* Die Hydrotect-Technologie befindet sich derzeit im Prozess der Registrierung, gemäß der europäischen Biozid-Verordnung Nr. 528/2012.

\* La Technologie 'Hydrotect' est actuellement en cours d'enregistrement conformément à la Réglementation Européenne des produits biocides nº 528/2012.

\* La tecnologia Hidrotect è attualmente in fase di registrazione in accordo con il regolamento Europeo sui Biocidi nº 528/2012.

\* Hydrotect technologie is momenteel in het proces van registratie voor de European Biocides Standard no. 528/12.

\* Technologia Hydrotect jest obecnie w trakcie rejestracji dla Europejskiego Standardu Biocydów nr 528/2012.

\* Технология HYDROTECT находится в процессе регистрации в соответствии с Регламентом 528/2012/ЕС «Положение о биоцидных веществах»



20MM

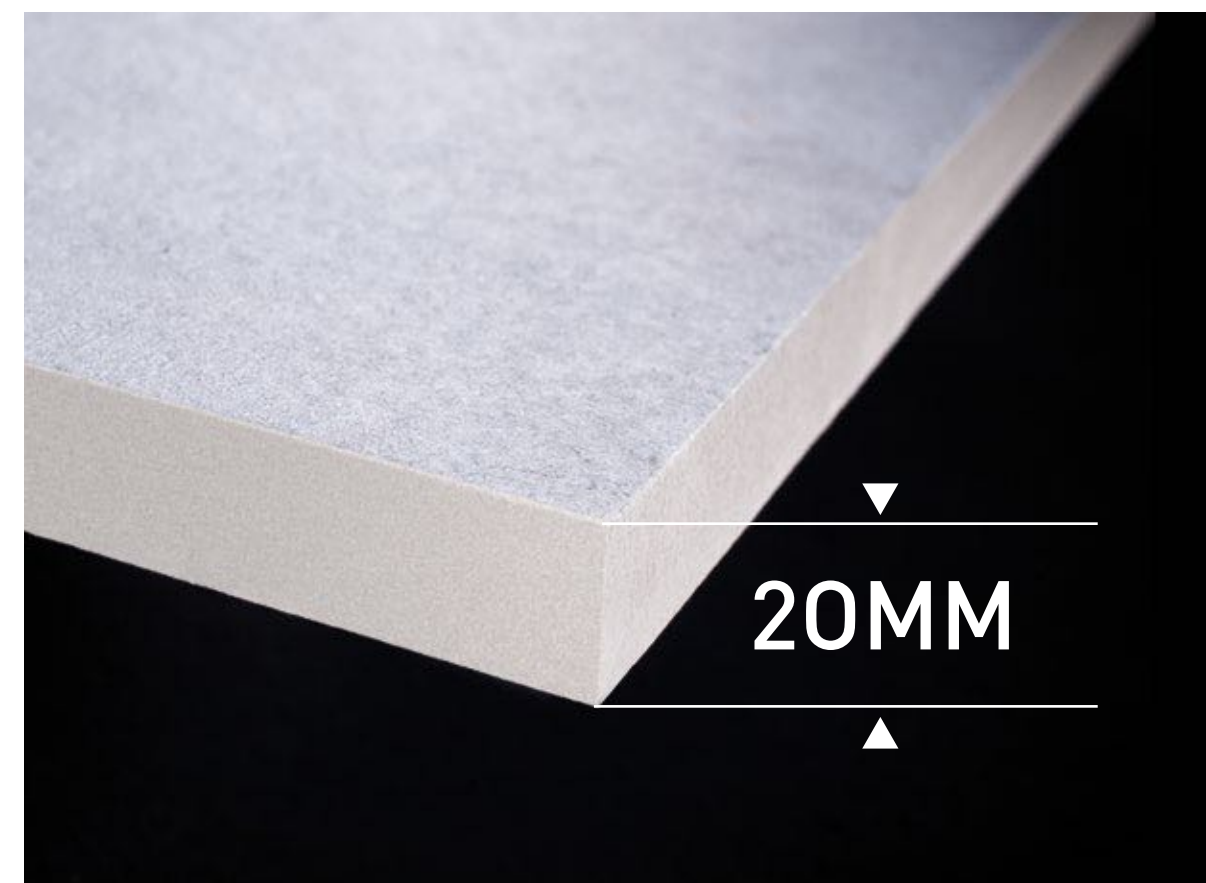

**30X120** 11<sup>13/16"</sup> X 47<sup>11/16"</sup> **20MM**  
 LYON 022  
 PATAGONIA 026

**60,3X60,3** 23<sup>3/4"</sup> X 23<sup>3/4"</sup> **20MM**  
 AVALON 012  
 CAUCASO 014  
 DOCK 016

**75X75** 29<sup>17/32"</sup> X 29<sup>17/32"</sup> **20MM**  
 DOCK 016  
 GEA 018  
 MONTREAL 024

**45X90** 17<sup>3/4"</sup> X 35<sup>7/16"</sup> **20MM**  
 ATLAS 010  
 LAVICA 020

**60X60** 23<sup>5/8"</sup> X 23<sup>5/8"</sup> **20MM**  
 GEA 018  
 LYON 022  
 PATAGONIA 026



BEIGE

IV



GRIS

IV



NEGRO

IV

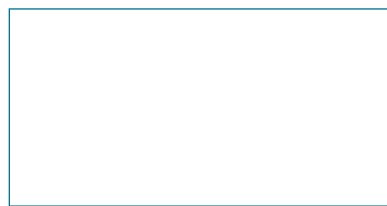

45x90 Atlas 20MM  
Beige 54AT77E (96-65)  
Gris 54AT37E (96-65)  
Negro 54AT97E (96-65)

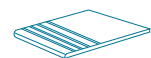

● Peldaño Porcelánico Romo Huella  
30x90 (20-10)

COMBINA CON EL PORCELÁNICO  
MATCHES PORCELAIN TILES  
**ATLAS** PÁG. 070

MULTIFORMATO

45X90 ATLAS  
22X90 ATLAS  
60X60 ATLAS  
30X60 ATLAS

Blanco, Beige, Gris,  
Negro



10mm



● Peldaño Escuadra  
30x30 (13-97)  
30x90 (20-40)

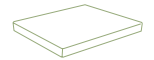

● Peldaño Escuadra Ang.  
30x30 (20-60)  
30x90 (20-50)



● Rodapié  
8x45 (11-81)  
8x60 (12-46)



≡ Pavimento: Atlas 20mm Gris 45x90.



alto

medida cm	nºpzax/box	m²/box	kg/box	boxes/pallet	m²/pallet	kg/pallet
45x90 20MM	2	0,81	36,23	24	19,44	869,52

**AVALON** 60,3X60,3 23<sup>3</sup>/<sub>4</sub>"X23<sup>3</sup>/<sub>4</sub>" 



CEMENTO

IV

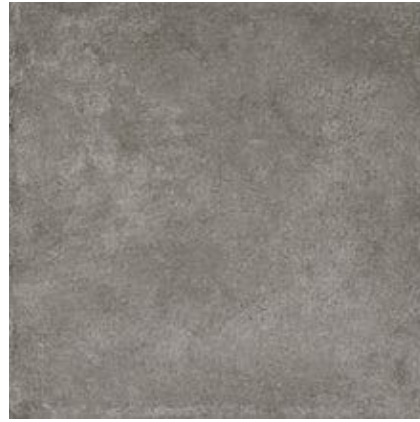

ANTRACITA

IV



MARENGO

IV

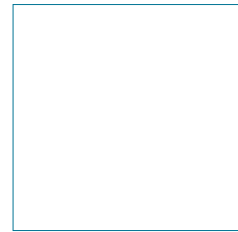

60,3x60,3 Avalon 20MM 

Cemento 52LNE15 (96-50)  
Antracita 52LNE65 (96-50)  
Marengo 52LNE55 (96-50)

COMBINA CON EL PORCELÁNICO  
MATCHES PORCELAIN TILES  
**AVALON** PÁG. 074

MULTIFORMATO  10mm  
80X80 AVALON  
40X80 AVALON  
60X60 AVALON  
7X28 AVALON  
Blanco, Cemento, Antracita,  
Taupé, Marengo

 Peldaño Escuadra  
30x30 (13-97)  
30x60 (20-60)

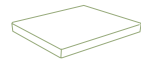
 Peldaño Escuadra Ang.  
30x30 (20-60)  
30x60 (20-70)

 Rodapié  
8x60 (12-46)  
8x80 (13-04)

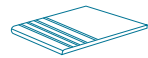
 Peldaño Porcelánico  
Romo Huella  
30x60,3 (13-81)



≡ Pavimento: Avalon 20mm Cemento 60,3 x 60,3.



R11  
C2/C3

B



alto

medida cm	nºpzax/box	m <sup>2</sup> /box	kg/box	boxes/pallet	m <sup>2</sup> /pallet	kg/pallet
60,3x60,3 20MM	2	0,73	33,50	32	23,36	1.072,00



CAUCASO 60,3X60,3 23<sup>3/4</sup>"X23<sup>3/4</sup>" 



BEIGE

IV



CEMENTO

IV



60,3x60,3 Caucaso   
 20MM Relieve  
 Beige 52CCE75 (96-50)  
 Cemento 52CCE15 (96-50)

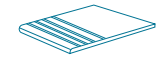

Peldaño Porcelánico  
 Romo Huella  
 30x60,3 (13-81)

COMBINA CON EL PORCELÁNICO  
 MATCHES PORCELAIN TILES

CAUCASO

MULTIFORMATO

45X90 CAUCASO 10,5mm (45x90)  
 60X60 CAUCASO 10mm(60x60/30x60)  
 30X60 CAUCASO  
 Beige, Gris, Cemento

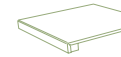

Peldaño Escuadra  
 30x30 (13-97)  
 30x90 (20-40)

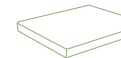

Peldaño Escuadra Ang.  
 30x30 (20-60)  
 30x90 (20-50)



Rodapié  
 8x45 (11-81)  
 8x60 (12-46)

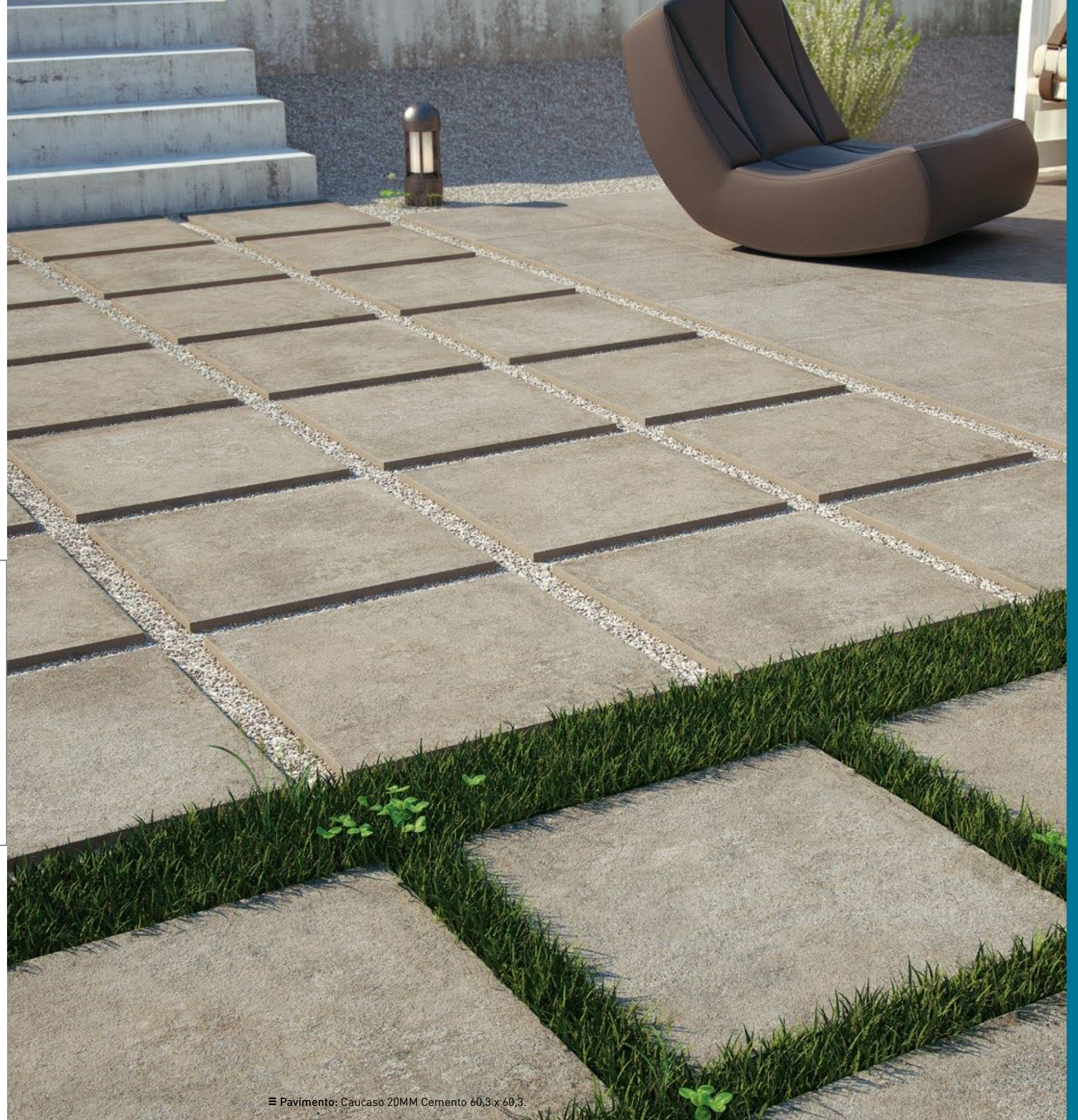

≡ Pavimento: Caucaso 20MM Cemento 60,3 x 60,3.



60,3x60,3



R12  
C2/C3



medio

medida cm	nºpzax/box	m²/box	kg/box	boxes/pallet	m²/pallet	kg/pallet
60,3x60,3 20MM	2	0,73	33,50	32	23,36	1.072,00

DOCK 75X75 29<sup>17/32</sup>" X 29<sup>17/32</sup>" **20MM** 60,3X60,3 23<sup>3/4</sup>" X 23<sup>3/4</sup>" **20MM**



BEIGE



GRIS



ANTRACITA



TAUPE



NEGRO

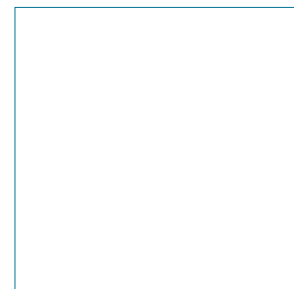

**75x75 Dock 20MM Relieve** **20MM**  
 Beige **61DOE76** (96-65)  
 Gris **61DOE36** (96-65)  
 Antracita **61DOE66** (96-65)

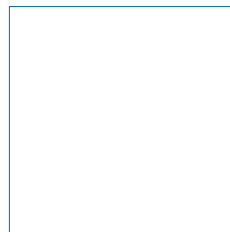

**60,3x60,3 Dock 20MM Relieve** **20MM**  
 Beige **52DOR75** (96-50)  
 Gris **52DOR35** (96-50)  
 Antracita **52DOR65** (96-50)  
 Taupe **52DOR25** (96-50)  
 Negro **52DOR95** (96-50)

**Peldaño Porcelánico Romo Huella**  
 30x75 (18-00)  
 30x60,3 (13-81)

COMBINA CON EL PORCELÁNICO  
 MATCHES PORCELAIN TILES  
**DOCK** PÁG. 112

MULTIFORMATO **10mm**  
 60X60 DOCK  
 30X60 DOCK  
 45X45 DOCK  
 Beige, Gris, Antracita,  
 Taupe, Negro

**Peldaño Escuadra**  
 30x30 (13-97)  
 30x60 (20-60)

**Peldaño Escuadra Ang.**  
 30x30 (20-60)  
 30x60 (20-70)

**Rodapié**  
 8x60 (12-46)



≡ Pavimento: Dock 20MM Antracita 60,3 x 60,3.

medida cm	nºpzax/box	m²/box	kg/box	boxes/pallet	m²/pallet	kg/pallet
75x75 20MM	1	0,56	24,91	42	23,63	1.046,22
60,3x60,3 20MM	2	0,73	33,50	32	23,36	1.072,00

GEA 75X75 29<sup>17/32</sup>"X29<sup>17/32</sup>" **20MM** 60X60 23<sup>5/8</sup>"X23<sup>5/8</sup>" **20MM**



CEMENTO

IV



ANTRACITA

IV

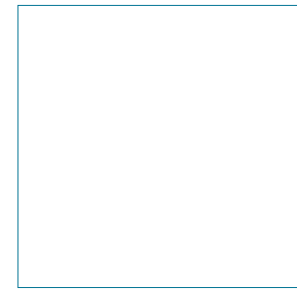

75x75 Gea 20MM

Cemento **61EGE16** (96-65)  
Antracita **61EGE66** (96-65)

**20MM**

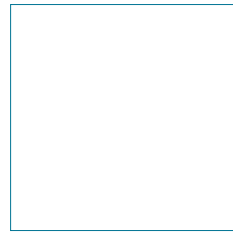

60x60 Gea 20MM

Cemento **52EGE15** (96-60)  
Antracita **52EGE65** (96-60)

**20MM**

COMBINA CON EL PORCELÁNICO  
MATCHES PORCELAIN TILES  
**GEA** PÁG. 120

MULTIFORMATO

60X120 GEA 11,3mm  
80X80 GEA 11,3mm  
60X60 GEA 10mm  
Blanco, Perla, Cemento,  
Taupé, Antacita



Peldaño Escuadra  
30x30 (13-97)  
30x120 (20-80)

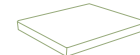

Peldaño Escuadra Ang.  
30x30 (20-60)  
30x120 (20-90)



Rodapié  
8x60 (12-46)  
8x80 (13-04)

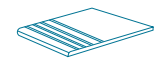

Peldaño Porcelánico  
Romo Huella  
30x75 (18-00)  
30x60 (13-81)



≡ Pavimento: Gea 20MM Antracita 75 x 75.

III Revestimiento: Coverlam Lava Corten 100 x 300.

medida cm	nºpzax/box	m²/box	kg/box	boxes/pallet	m²/pallet	kg/pallet
75x75 20MM	1	0,56	24,91	42	23,63	1.046,22
60x60 20MM	2	0,73	33,50	32	23,36	1.072,00



R11  
C2/C3 **B**



medio

LAVICA 45X90 17<sup>3</sup>/<sub>4</sub>"X35<sup>7</sup>/<sub>16</sub>"



LAVICA



45x90 Lavica Relieve 20MM  
54LA97E (96-65)

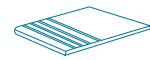

● Peldaño Porcelánico Romo Huella  
30x90 (20-10)

COMBINA CON EL PORCELÁNICO  
MATCHES PORCELAIN TILES  
**LAVICA** PÁG. 038

MULTIFORMATO  
60X120 LAVICA 11,3mm (80x80/60x120)  
80X80 LAVICA 10mm (30x60/60x60)  
60X60 LAVICA  
30X60 LAVICA



● Peldaño Escuadra  
30x30 (12-80)  
30x120 (20-80)



● Peldaño Escuadra Ang.  
30x30 (12-80)  
30x120 (20-90)

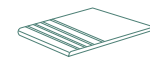

● Peldaño Porcelánico Romo Huella  
30x30 (12-80)  
30x120 (20-13)



● Rodapié  
8x30 (12-46)  
8x80 (13-04)



T PORCELÁNICO TÉCNICO / TODO MASA  
PORCELAIN TILES / FULL BODY

NUEVO NEW

≡ Pavimento: Lavica 20mm Gris 45x90.

medida cm	nºpzax/box	m²/box	kg/box	boxes/pallet	m²/pallet	kg/pallet
45x90 20MM	2	0,81	36,23	24	19,44	869,52



medio

LYON 30X120 11<sup>13/16</sup>" X 47<sup>11/16</sup>" **20MM** 60X60 23<sup>5/8</sup>" X 23<sup>5/8</sup>" **20MM**



GRIS



GALENA



TAUPE

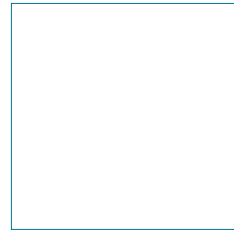

**60x60 Lyon 20MM Relieve** **20MM**

Gris **55LY320** (96-60)  
Galena **55LY520** (96-60)  
Taupe **55LY220** (96-60)

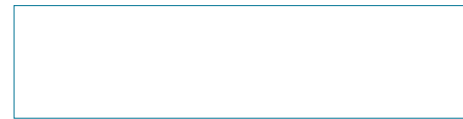

**30x120 Lyon 20MM Relieve** **20MM**

Gris **59LY39M** (96-70)  
Galena **59LY59M** (96-70)  
Taupe **59LY29M** (96-70)

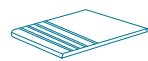

**Peldaño Porcelánico Romo Huella**  
30x60 (13-81)  
30x120 (20-14)

COMBINA CON EL PORCELÁNICO  
MATCHES PORCELAIN TILES  
**LYON** PÁG. 042

MULTIFORMATO

**80X80 LYON**  
**40X80 LYON**  
**60X60 LYON**  
**30X60 LYON**  
**30X30 LYON**

Marfil, Gris, Antracita,  
Galena, Taupe

11,3mm (80x80/40x80)  
10mm (30x60/60x60/30x30)

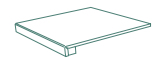

**Peldaño Escuadra**  
30x30 (13-97)  
30x60 (20-60)

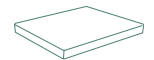

**Peldaño Escuadra Ang.**  
30x30 (20-60)  
30x60 (20-70)

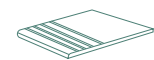

**Peldaño Porcelánico Romo Huella**  
30x30 (12-80)  
30x60 (13-70)



**Rodapié**  
8x60 (12-46)

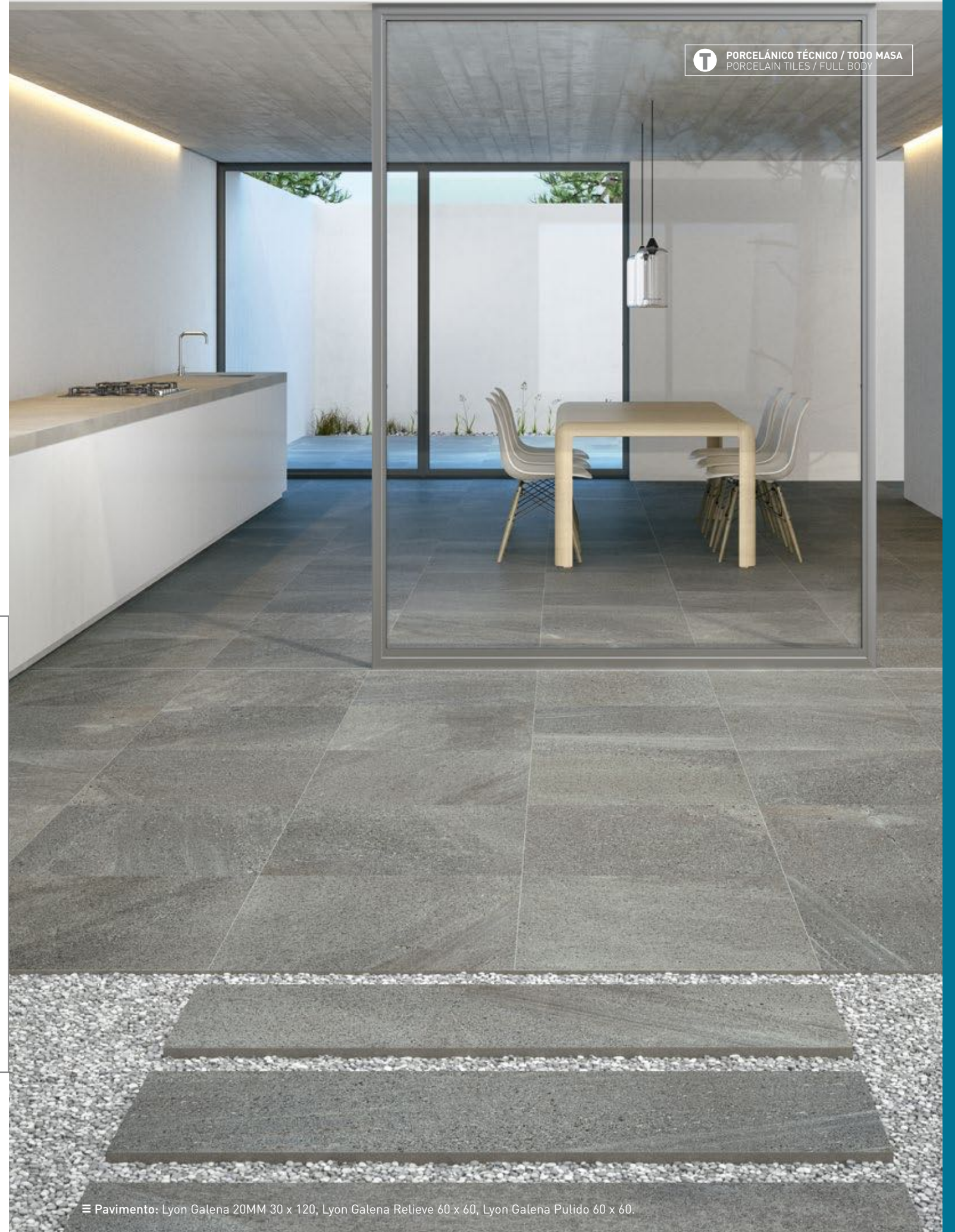

**T** PORCELÁNICO TÉCNICO / TODO MASA  
PORCELAIN TILES / FULL BODY

≡ Pavimento: Lyon Galena 20MM 30 x 120, Lyon Galena Relieve 60 x 60, Lyon Galena Pulido 60 x 60.

medida cm	nºpzax/box	m²/box	kg/box	boxes/pallet	m²/pallet	kg/pallet
30x120 20MM	2	0,72	33,50	20	14,40	670,00
60x60 20MM	2	0,73	33,50	32	23,36	1.072,00





BLANCO



CEMENTO



GRIS



TAUPÉ



ANTRACITA

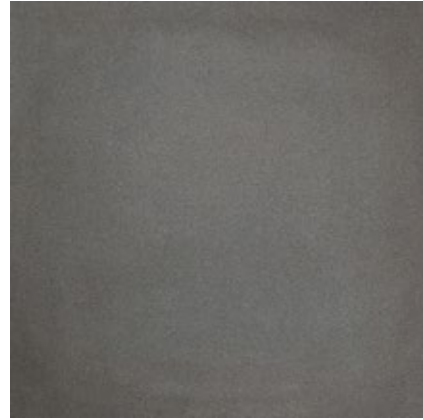

NEGRO



75x75 Montreal 20MM



Blanco **61MTE46** (96-65)  
Gris **61MTE36** (96-65)  
Cemento **61MTE16** (96-65)  
Taupé **61MTE26** (96-65)  
Antracita **61MTE66** (96-65)  
Negro **61MTE96** (96-65)

**Peldaño Porcelánico Romo Huella**  
30x75 (18-00)

COMBINA CON EL PORCELÁNICO  
MATCHES PORCELAIN TILES  
**MONTREAL** PÁG. 048



MULTIFORMATO  
80X80 MONTREAL  
60X60 MONTREAL  
30X60 MONTREAL  
30X30 MONTREAL  
15X15 MONTREAL  
Blanco, Cemento, Gris,  
Antracita, Taupé, Negro

11,3mm (80x80)  
10mm  
(30x60/60x60/30x30/15x15)  
**T**

- Peldaño Escuadra**  
30x30 (13-97)  
30x80 (20-40)
- Peldaño Escuadra Ang.**  
30x30 (20-60)  
30x80 (20-50)
- Peldaño Porcelánico Romo Huella**  
30x30 (12-80)  
30x80 (18-00)
- Rodapié**  
8x60 (12-65)  
8x80 (13-04)

≡ Pavimento: Montreal 20MM Gris 75 x 75.

medida cm	nºpzax/box	m²/box	kg/box	boxes/pallet	m²/pallet	kg/pallet
75x75 20MM	1	0,56	24,91	42	23,63	1.046,22

PATAGONIA 30X120 11<sup>13/16</sup>"X47<sup>11/16</sup>"  60X60 23<sup>5/8</sup>"X23<sup>5/8</sup>" 



FRESNO



CASTAÑO



ENCINA

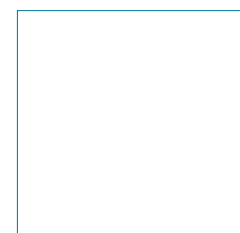

**60x60 Patagonia 20MM**   
 Fresno **52PT55R** (96-60)  
 Castaño **52PT85R** (96-60)  
 Encina **52PT15R** (96-60)

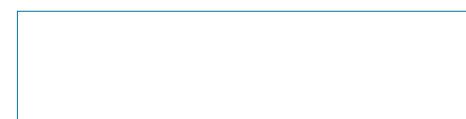

**30x120 Patagonia 20MM**   
 Fresno **59PT59R** (96-70)  
 Castaño **59PT89R** (96-70)  
 Encina **59PT19R** (96-70)

COMBINA CON EL PORCELÁNICO  
 MATCHES PORCELAIN TILES  
**PATAGONIA** PÁG. 160

MULTIFORMATO  11,3mm  
 14,5X120 PATAGONIA  
 19,5X129 PATAGONIA

Fresno, Roble, Castaño,  
 Azahar, Encina, Ébano.

 **Peldaño Escuadra**  
 30x30 (13-97)  
 120 x 30 (20-80)

 **Peldaño Escuadra Ang.**  
 30x30 (20-60)  
 120 x 30 (20-90)

 **Rodapié**  
 8x60 (12-65)

 **Peldaño Porcelánico**  
 Romo Huella  
 30x60 (13-81)  
 30x120 (20-14)



≡ Pavimento: Patagonia 20MM Castaño 30 x 120.



medida cm	nºpzax/box	m²/box	kg/box	boxes/pallet	m²/pallet	kg/pallet
30x120 20MM	2	0,72	33,50	20	14,40	670,00
60x60 20MM	2	0,73	33,50	32	23,36	1.072,00

## PORCELÁNICO TÉCNICO - TODO MASA THROUGHBODY PORCELAIN TILES - FULL BODY

GRÈS CÉRAME TECHNIQUE - PLEIN MASSE  
FEINSTEINZEUG - UNGLASIERT  
PORCELLANATO TECNICO - TUTTA MASSA  
GRES TECHNICZNY - BARWIONY W PEŁNEJ MASIE  
FULL BODY TEGELS  
КОЛОРИРОВАННЫЙ В МАССЕ ТЕХНИЧЕСКИЙ КЕРАМОГРАНИТ



### 60X120 47<sup>11/16</sup>" X 23<sup>5/8</sup>"

ALPES	030
LAVICA	036 <b>N</b>
STARK	056
TITAN	058

### 45X90 17<sup>3/4</sup>" X 35<sup>7/16</sup>"

LAVICA	036 <b>N</b>
--------	--------------

### 80X80 31<sup>1/2</sup>" X 31<sup>1/2</sup>"

LAVICA	036 <b>N</b>
LYON	040
METEOR	044
MONTREAL	048 <b>N</b>
NEXO	052

### 40X80 15<sup>6/4</sup>" X 31<sup>1/2</sup>"

LYON	040
------	-----

### 45X45 17<sup>3/4</sup>" X 17<sup>3/4</sup>"

ATACAMA	032
---------	-----

### 60X60 23<sup>5/8</sup>" X 23<sup>5/8</sup>"

ALPES	030
ATACAMA	032
CITY	034
LAVICA	036 <b>N</b>
LYON	040
METEOR	044
MONTREAL	048 <b>N</b>
NEXO	052
STARK	056
TITAN	058

### 30X60 11<sup>13/16</sup>" X 23<sup>5/8</sup>"

ALPES	030
ATACAMA	032
LAVICA	036 <b>N</b>
LYON	040
METEOR	044
MONTREAL	048 <b>N</b>
NEXO	052

### 30X30 11<sup>13/16</sup>" X 11<sup>13/16</sup>"

ALPES	030
CITY	034
LYON	040
METEOR	044
MONTREAL	048 <b>N</b>
NEXO	052

### 15X15 5<sup>7/8</sup>" X 5<sup>7/8</sup>"

ATACAMA	032
LYON	040
METEOR	044
MONTREAL	048 <b>N</b>
NEXO	052

**N**  
nuevo · new · nouveau  
neu · nuovo · nowość nieuw  
· новое





BLANCO



GRAFITO



NEGRO

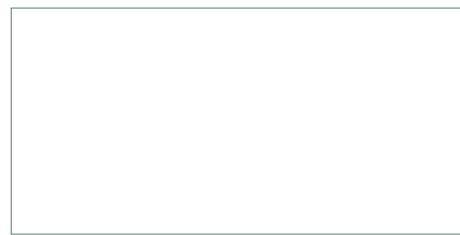

60x120 Alps  
Blanco **58AP49R** [06-03]  
Grafito **58AP69R** [06-03]  
Negro **58AP99R** [06-03]

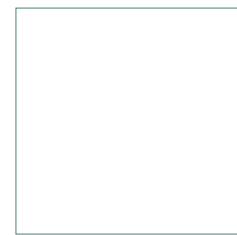

60x60 Alps  
Blanco **52AP45R** [05-58]  
Grafito **52AP65R** [05-58]  
Negro **52AP95R** [05-58]



30x60 Alps  
Blanco **47AP42R** [05-05]  
Grafito **47AP62R** [05-05]  
Negro **47AP92R** [05-05]



30x30 Alps  
Blanco **60AP-40** [05-15]  
Grafito **60AP-60** [05-15]  
Negro **60AP-90** [05-15]



III Revestimiento: Alps Grafito 60 x 120, Valle Negro 16 x 60.

≡ Pavimento: Alps Negro 60 x 120



16x60 Valle  
Blanco **08VA-44** [13-05]  
Grafito **08VA-64** [13-05]  
Negro **08VA-94** [13-05]



30x30 Cima  
Blanco **41AP40C** [09-05]  
Grafito **41AP60C** [09-05]  
Negro **41AP90C** [09-05]

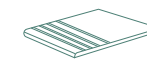

Peldaño Porcelánico Romo Huella  
30x30 [12-80]  
30x120 [20-13]



Peldaño Escuadra  
30x30 [13-97]  
30x120 [20-80]

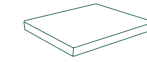

Peldaño Escuadra Ang.  
30x30 [20-60]  
30x120 [20-90]



Rodapié  
8x60 [12-46]

medida cm	nº pzas/box	m <sup>2</sup> /box	kg/box	boxes/pallet	m <sup>2</sup> /pallet	kg/pallet
60x120	2	1,44	38,50	25	36,00	962,50
60x60	3	1,08	25,75	32	34,56	824,00
30x60	6	1,08	24,80	40	43,20	992,00
30x30	9	0,81	18,45	38,88	38,88	717,34



11,3mm [120x60]  
10mm [30x30/30x60/60x60]



ATACAMA 60X60 23<sup>5/8</sup>"X23<sup>5/8</sup>" 45X45 17<sup>3/4</sup>"X17<sup>3/4</sup>" 30X60 11<sup>13/16</sup>"X23<sup>5/8</sup>" 15X15 5<sup>7/8</sup>" X5<sup>7/8</sup>"

T PORCELÁNICO TÉCNICO / TODO MASA  
PORCELAIN TILES / FULL BODY



BLANCO



GRIS



MARENGO



NEGRO



BEIGE



TABACO

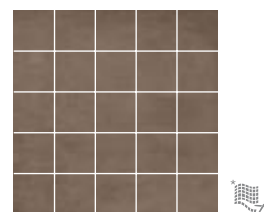

**Paine 30x30**  
Tabaco **41PA-20** (09-05) Marengo **41PA-50** (09-05)  
Blanco **41PA-40** (09-05) Negro **41PA-90** (09-05)  
Gris **41PA-30** (09-05) Beige **41PA-70** (09-05)

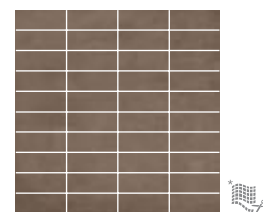

**Chiloe 30x30**  
Tabaco **41CH-20** (09-30) Marengo **41CH-50** (09-30)  
Blanco **41CH-40** (09-30) Negro **41CH-90** (09-30)  
Gris **41CH-30** (09-30) Beige **41CH-70** (09-30)



**14,5x60 / 9,7x60 / 4,7x60**  
**Atacama Mix 60**  
Blanco **57AT4MX** (05-84)  
Gris **57AT3MX** (05-84)  
Marengo **57AT5MX** (05-84)  
Negro **57AT9MX** (05-84)  
Beige **57AT7MX** (05-84)  
Tabaco **57AT2MX** (05-84)

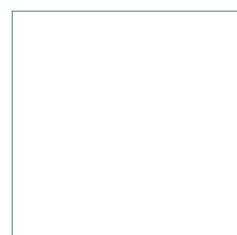

**60x60 Atacama**  
Blanco **52AT45R** (07-83)  
Gris **52AT35R** (07-83)  
Marengo **52AT55R** (07-83)  
Negro **52AT95R** (07-83)  
Beige **52AT75R** (07-83)  
Tabaco **52AT25R** (07-83)



**45x45 Atacama**  
Blanco **42AT-48** (07-70)  
Gris **42AT-38** (07-70)  
Marengo **42AT-58** (07-70)  
Negro **42AT-98** (07-70)  
Beige **42AT-78** (07-70)  
Tabaco **42AT-28** (07-70)

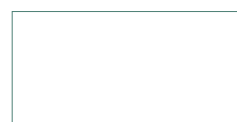

**30x60 Atacama**  
Blanco **46AT-42** (07-76)  
Gris **46AT-32** (07-76)  
Marengo **46AT-52** (07-76)  
Negro **46AT-92** (07-76)  
Beige **46AT-72** (07-76)  
Tabaco **46AT-22** (07-76)



**15x15 Atacama**  
Blanco **06TATA4** (05-12)  
Gris **06TATA3** (05-12)  
Marengo **06TATA5** (05-12)  
Negro **06TATA9** (05-12)  
Beige **06TATA7** (05-12)  
Tabaco **06TATA2** (05-12)

**30x60 Atacama Rectificado**  
Blanco **46AT42R** (07-82)  
Gris **46AT32R** (07-82)  
Marengo **46AT52R** (07-82)  
Negro **46AT92R** (07-82)  
Beige **46AT72R** (07-82)  
Tabaco **46AT22R** (07-82)

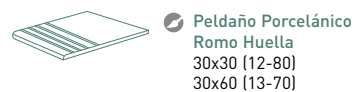

**Peldaño Porcelánico Romo Huella**  
30x30 (12-80)  
30x60 (13-70)

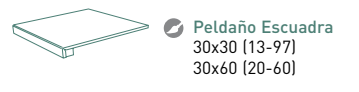

**Peldaño Escuadra**  
30x30 (13-97)  
30x60 (20-60)

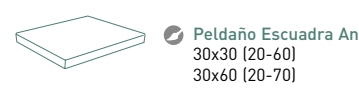

**Peldaño Escuadra Ang.**  
30x30 (20-60)  
30x60 (20-70)

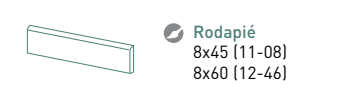

**Rodapié**  
8x45 (11-08)  
8x60 (12-46)

**60x60 Atacama Antislip**  
Blanco **52ATA45** (07-89)  
Gris **52ATA35** (07-89)  
Marengo **52ATA55** (07-89)  
Negro **52ATA95** (07-89)  
Beige **52ATA75** (07-89)  
Tabaco **52ATA25** (07-89)

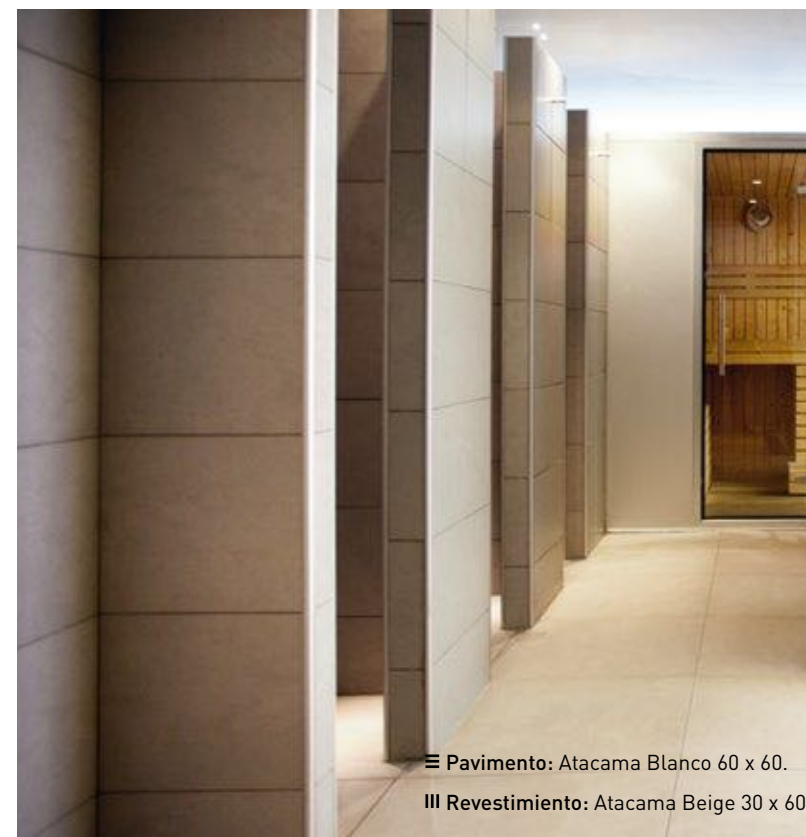

III Pavimento: Atacama Blanco 60 x 60.  
III Revestimiento: Atacama Beige 30 x 60.



III Pavimento: Atacama Gris Antislip 60 x 60.

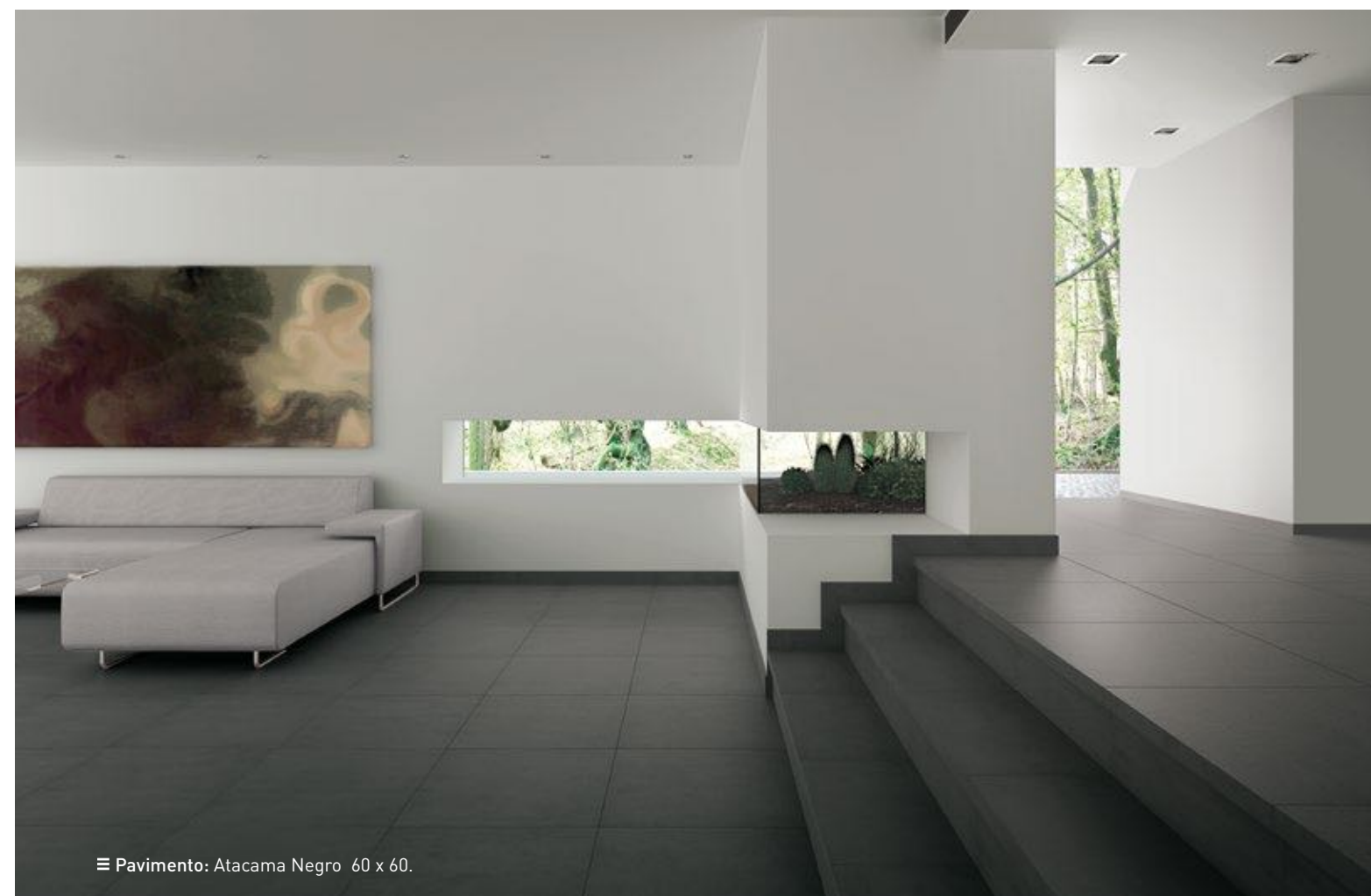

III Pavimento: Atacama Negro 60 x 60.

medida cm	nºpzax/box	m²/box	kg/box	boxes/pallet	m²/pallet	kg/pallet
60x60	3	1,08	25,75	32	34,56	824,00
45x45	5	1,01	23,30	66	66,66	1.537,80
30x60	6	1,08	24,80	40	43,20	992,00
30x30 mallado	9	0,81	18,45	38,88	38,88	717,34
15x15	20	0,45	7,80	100	-	-



CITY 60X60 23<sup>5/8</sup>"X23<sup>5/8</sup>" 15MM 30X30 11<sup>13/16</sup>"X11<sup>13/16</sup>" 15MM

T PORCELÁNICO TÉCNICO / TODO MASA  
PORCELAIN TILES / FULL BODY



MARRÓN



GRIS

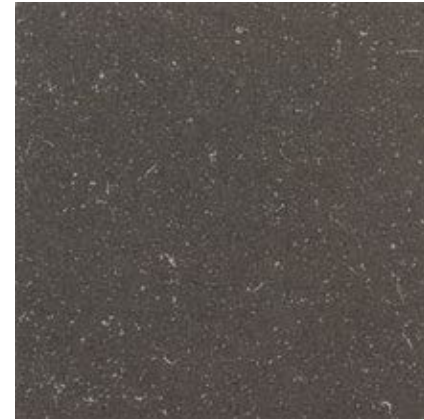

NEGRO



9,6x60 Line 15MM  
Beige 08LI-71 (13-11)  
Gris 08LI-31 (13-11)  
Marrón 08LI-21 (13-11)  
Negro 08LI-91 (13-11)



30x30 Park 15MM  
Blanco 60PA-40 (04-90)

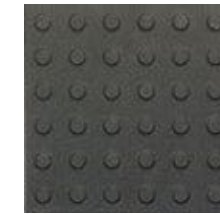

30x30 Park 15MM  
Negro 60PA-90 (04-90)



30x30 Park 15MM  
Gris 60PA-30 (04-90)

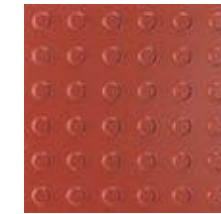

30x30 Park 15MM  
Rojo 60PA-80 (04-90)

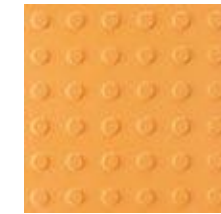

30x30 Park 15MM  
Naranja 60PA-00 (04-90)

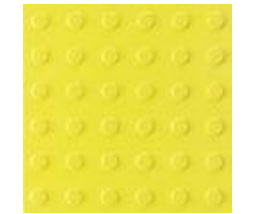

30x30 Park 15MM  
Amarillo 60PA-20 (04-90)



30x30 Center 15MM  
Blanco 60CE-40 (04-90)



30x30 Center 15MM  
Negro 60CE-90 (04-90)



30x30 Center 15MM  
Gris 60CE-30 (04-90)



30x30 Center 15MM  
Rojo 60CE-80 (04-90)



30x30 Center 15MM  
Naranja 60CE-00 (04-90)



30x30 Center 15MM  
Amarillo 60CE-20 (04-90)

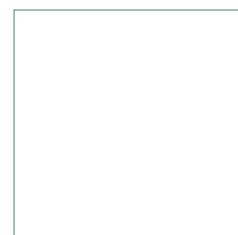

60x60 City Liso 15MM  
Marrón 55CY-25 (04-81)  
Gris 55CY-35 (04-81)  
Negro 55CY-95 (04-81)



30x30 City Liso 15MM  
Gris 60CY-30 (04-78)  
Marrón 60CY-20 (04-78)  
Negro 60CY-90 (04-78)



60x60 City Relieve 15MM  
Marrón 55CYR25 (04-81)  
Gris 55CYR35 (04-81)  
Negro 55CYR95 (04-81)

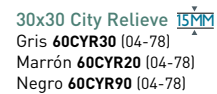

30x30 City Relieve 15MM  
Gris 60CYR30 (04-78)  
Marrón 60CYR20 (04-78)  
Negro 60CYR90 (04-78)



60x60 City Antislip 15MM  
Marrón 55CYA25 (04-81)  
Gris 55CYA35 (04-81)  
Negro 55CYA95 (04-81)



30x30 City Antislip 15MM  
Gris 60CYA30 (04-78)  
Marrón 60CYA20 (04-78)  
Negro 60CYA90 (04-78)

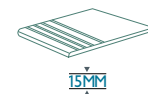

Peldaño Porcelánico  
Romo Huella  
30x30 (12-80)  
30x60 (13-70)

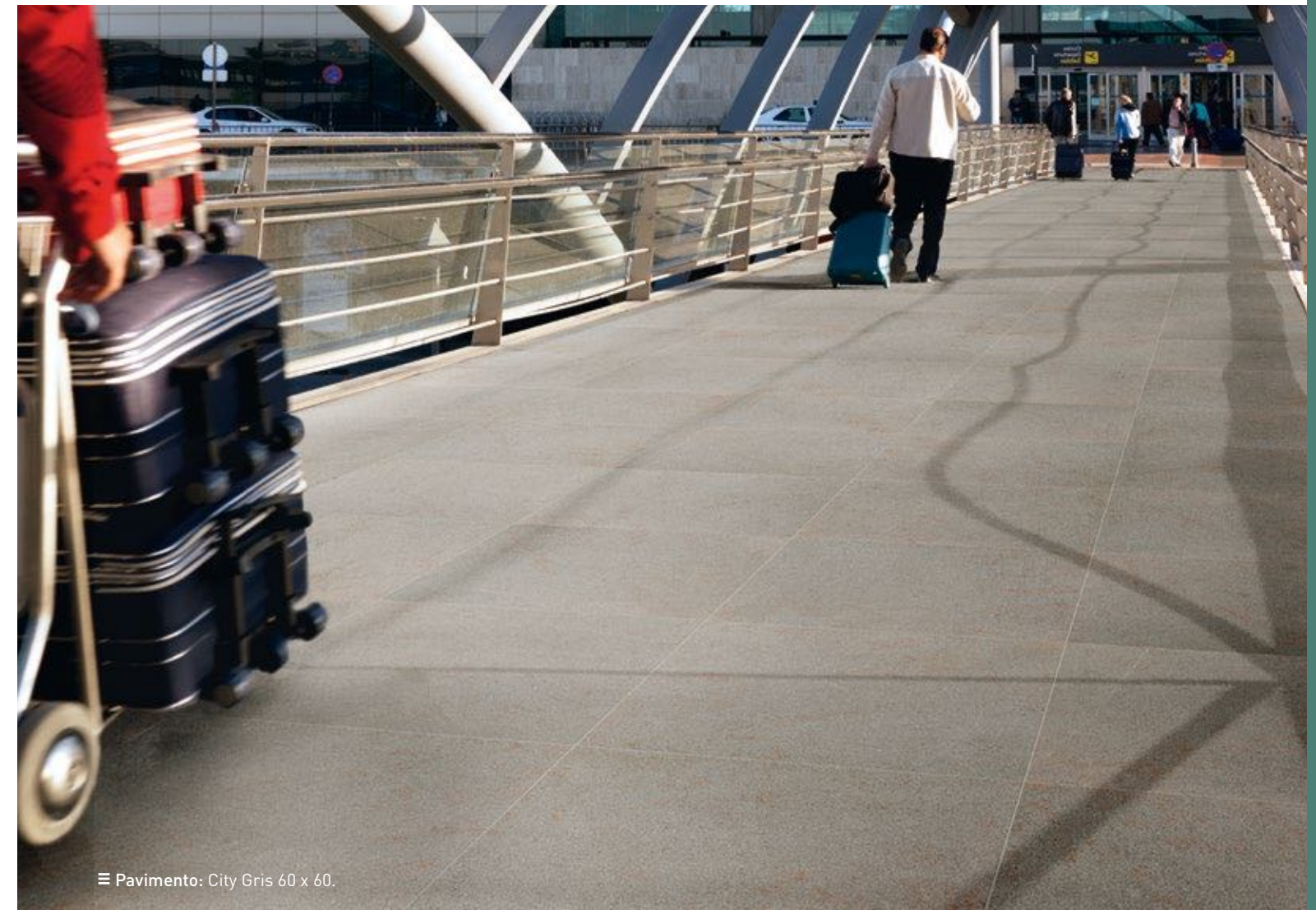

Pavimento: City Gris 60 x 60.

medida cm	nº pzas/box	m²/box	kg/box	boxes/pallet	m²/pallet	kg/pallet
60x60 15MM	2	0,72	26,25	32	23,04	840,00
30x30 15MM	6	0,54	19,10	48	25,92	916,80
30X30 CENTER 15MM	6	0,54	18,45	48	25,92	885,60
30X30 PARK 15MM	6	0,54	19,50	48	25,92	936,00



LAVICA 60X120 23<sup>5/8</sup>" X 47<sup>11/16</sup>" 80X80 31<sup>1/2</sup>" X 31<sup>1/2</sup>" 60X60 23<sup>5/8</sup>" X 23<sup>5/8</sup>" 30X60 11<sup>13/16</sup>" X 23<sup>5/8</sup>"  
45X90 17<sup>3/4</sup>" X 35<sup>7/16</sup>" 

 PORCELÁNICO TÉCNICO / TODO MASA  
PORCELAIN TILES / FULL BODY

NUEVO NEW



PORCELÁNICO TÉCNICO TODO MASA THROUGHBODY PORCELAIN TILES - FULL BODY

III Revestimiento: Lavica Natural 60 x 60, Vulcanic 60 x 60.

≡ Pavimento: Lavica Natural 60x120, Lavica Relieve 60x120.

**LAVICA** 60X120 23<sup>5/8</sup>"X 47<sup>11/16</sup>" 80X80 31<sup>1/2</sup>"X31<sup>1/2</sup>" 60X60 23<sup>5/8</sup>"X23<sup>5/8</sup>" 30X60 11<sup>13/16</sup>"X23<sup>5/8</sup>"  
 45X90 17<sup>3/4</sup>"X35<sup>7/16</sup>" **20MM**

**T** PORCELÁNICO TÉCNICO / TODO MASA  
 PORCELAIN TILES / FULL BODY

**NUEVO NEW**



LAVICA

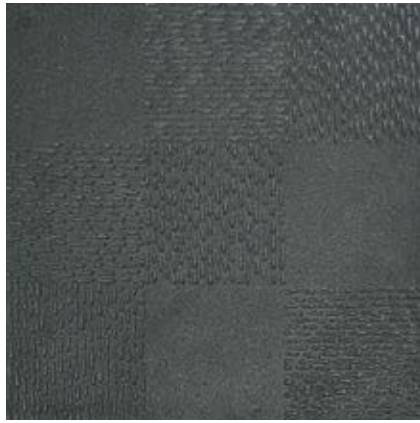
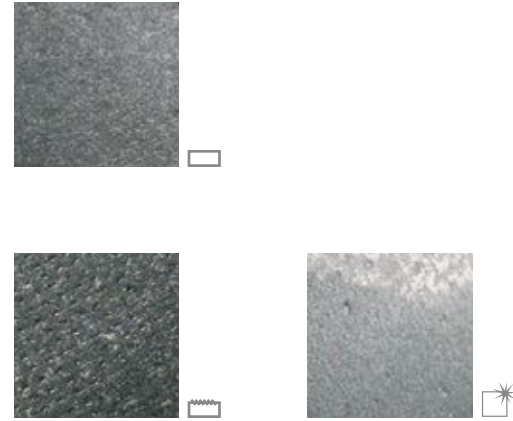

**VULCANIC 60X60**  
**52LA925** (07-89)

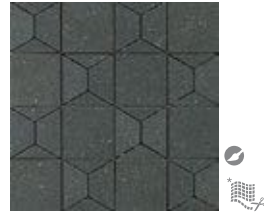

**MANTO 30X30**  
**08LA90M** (13-78)



**CALDERA 30X30**  
**08LA90C** (13-73)

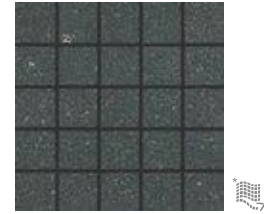

**MAGMA 30X30**  
**41LA90M** (09-05)

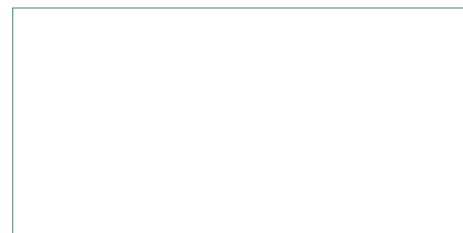

**60x120 Lavica Natural**  
**58LA99R** (08-08)  
**60x120 Lavica Pulido**  
**58LA99P** (08-55)  
**60x120 Lavica Relieve**  
**58LA919** (08-08)

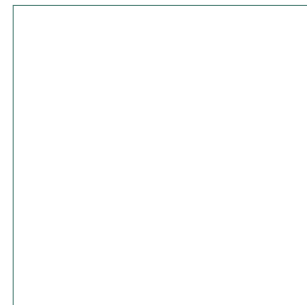

**80x80 Lavica Natural**  
**61LA96R** (06-07)  
**80x80 Lavica Pulido**  
**61LA96P** (06-10)  
**80x80 Lavica Relieve**  
**61LA916** (06-07)



**60x60 Lavica Natural**  
**52LA95R** (08-05)  
**60x60 Lavica Pulido**  
**52LA95P** (07-94)  
**60x60 Lavica Relieve**  
**52LA915** (08-05)



**30x60 Lavica Natural**  
**46LA92R** (07-83)  
**30x60 Lavica Pulido**  
**46LA92P** (07-93)  
**30x60 Lavica Relieve**  
**46LA912** (07-83)

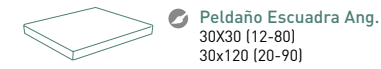

**Peldaño Escuadra Ang.**  
 30X30 (12-80)  
 30x120 (20-90)



**Rodapié**  
 8x30 (12-46)  
 8X80 (13-04)

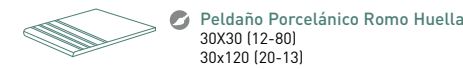

**Peldaño Porcelánico Romo Huella**  
 30X30 (12-80)  
 30x120 (20-13)



**Peldaño Escuadra**  
 30X30 (12-80)  
 30x120 (20-80)

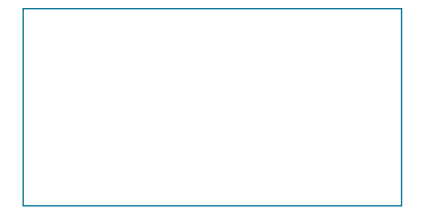

**45x90 Lavica Relieve 20MM**  
**54LA97E** (96-65)

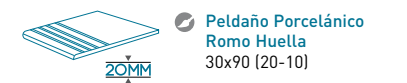

**Peldaño Porcelánico Romo Huella**  
 30x90 (20-10)

medida cm	nºpzax/box	m²/box	kg/box	boxes/pallet	m²/pallet	kg/pallet
60x120	2	1,44	38,50	25	36,00	962,00
80x80	2	1,28	34,25	40	51,20	1.370,00
60x60	3	1,08	25,75	32	34,56	824,00
30x60	6	1,08	24,80	40	43,20	992,00
45x90 20MM	2	0,81	36,23	24	19,44	869,52



**LYON** 80X80 31<sup>1</sup>/<sub>2</sub>"X31<sup>1</sup>/<sub>2</sub>" 80X40 31<sup>1</sup>/<sub>2</sub>"X15<sup>6</sup>/<sub>4</sub>" 60X60 23<sup>5</sup>/<sub>8</sub>"X23<sup>5</sup>/<sub>8</sub>" 30X60 11<sup>13</sup>/<sub>16</sub>"X23<sup>5</sup>/<sub>8</sub>"  
30X30 11<sup>13</sup>/<sub>16</sub>"X11<sup>13</sup>/<sub>16</sub>" 15X15 5<sup>7</sup>/<sub>8</sub>" X5<sup>7</sup>/<sub>8</sub>"  
30X120 11<sup>13</sup>/<sub>16</sub>"X 47<sup>11</sup>/<sub>16</sub>" **20MM** 60X60 23<sup>5</sup>/<sub>8</sub>"X23<sup>5</sup>/<sub>8</sub>" **20MM**

**T** PORCELÁNICO TÉCNICO / TODO MASA  
PORCELAIN TILES / FULL BODY



**LYON** 80X80 31<sup>1</sup>/<sub>2</sub>"X31<sup>1</sup>/<sub>2</sub>" 80X40 31<sup>1</sup>/<sub>2</sub>"X15<sup>6</sup>/<sub>4</sub>" 60X60 23<sup>5</sup>/<sub>8</sub>"X23<sup>5</sup>/<sub>8</sub>" 30X60 11<sup>13</sup>/<sub>16</sub>"X23<sup>5</sup>/<sub>8</sub>"  
 30X30 11<sup>13</sup>/<sub>16</sub>"X11<sup>13</sup>/<sub>16</sub>" 15X15 5<sup>7</sup>/<sub>8</sub>" X5<sup>7</sup>/<sub>8</sub>"  
 30X120 11<sup>13</sup>/<sub>16</sub>"X 47<sup>11</sup>/<sub>16</sub>" **20MM** 60X60 23<sup>5</sup>/<sub>8</sub>"X23<sup>5</sup>/<sub>8</sub>" **20MM**

**T** PORCELÁNICO TÉCNICO / TODO MASA  
 PORCELAIN TILES / FULL BODY



MARFIL



GRIS



GALENA



ANTRACITA



TAUPE

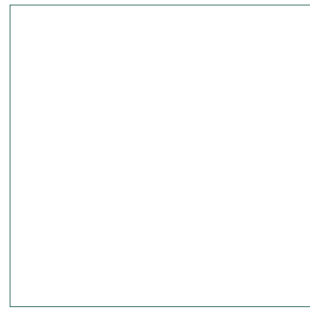
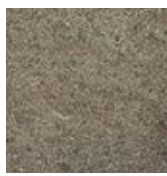
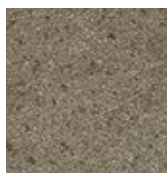

**80x80 Lyon Relieve**  
 Marfil **61LY46R** (05-69)  
 Gris **61LY36R** (05-69)  
 Galena **61LY56R** (05-69)  
 Taupe **61LY26R** (05-69)  
 Antracita **61LY66R** (05-69)



**40x80 Lyon Relieve**  
 Marfil **61LY43R** (05-86)  
 Gris **61LY33R** (05-86)  
 Galena **61LY53R** (05-86)  
 Taupe **61LY23R** (05-86)  
 Antracita **61LY63R** (05-86)



**60x60 Lyon Relieve**  
 Marfil **55LY45R** (05-58)  
 Gris **55LY35R** (05-58)  
 Galena **55LY55R** (05-58)  
 Taupe **55LY25R** (05-58)  
 Antracita **55LY65R** (05-58)

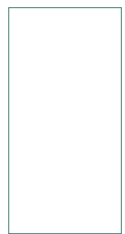

**30x60 Lyon Relieve**  
 Marfil **47LY42R** (05-37)  
 Gris **47LY32R** (05-37)  
 Galena **47LY52R** (05-37)  
 Taupe **47LY22R** (05-37)  
 Antracita **47LY62R** (05-37)



**30x30 Lyon Relieve**  
 Marfil **60LY40R** (05-15)  
 Gris **60LY30R** (05-15)  
 Galena **60LY50R** (05-15)  
 Taupe **60LY20R** (05-15)  
 Antracita **60LY60R** (05-15)



**80x80 Lyon Natural**  
 Marfil **61LY46N** (05-69)  
 Gris **61LY36N** (05-69)  
 Galena **61LY56N** (05-69)  
 Taupe **61LY26N** (05-69)  
 Antracita **61LY66N** (05-69)

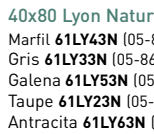

**40x80 Lyon Natural**  
 Marfil **61LY43N** (05-86)  
 Gris **61LY33N** (05-86)  
 Galena **61LY53N** (05-86)  
 Taupe **61LY23N** (05-86)  
 Antracita **61LY63N** (05-86)

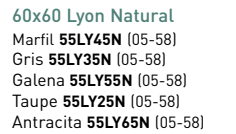

**60x60 Lyon Natural**  
 Marfil **55LY45N** (05-58)  
 Gris **55LY35N** (05-58)  
 Galena **55LY55N** (05-58)  
 Taupe **55LY25N** (05-58)  
 Antracita **55LY65N** (05-58)



**30x60 Lyon Natural**  
 Marfil **47LY42N** (05-37)  
 Gris **47LY32N** (05-37)  
 Galena **47LY52N** (05-37)  
 Taupe **47LY22N** (05-37)  
 Antracita **47LY62N** (05-37)



**30x30 Lyon Natural**  
 Marfil **60LY40N** (05-15)  
 Gris **60LY30N** (05-15)  
 Galena **60LY50N** (05-15)  
 Taupe **60LY20N** (05-15)  
 Antracita **60LY60N** (05-15)

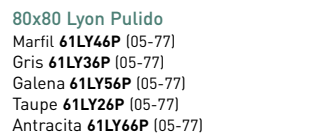

**80x80 Lyon Pulido**  
 Marfil **61LY46P** (05-77)  
 Gris **61LY36P** (05-77)  
 Galena **61LY56P** (05-77)  
 Taupe **61LY26P** (05-77)  
 Antracita **61LY66P** (05-77)

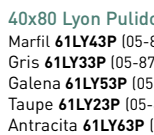

**40x80 Lyon Pulido**  
 Marfil **61LY43P** (05-87)  
 Gris **61LY33P** (05-87)  
 Galena **61LY53P** (05-87)  
 Taupe **61LY23P** (05-87)  
 Antracita **61LY63P** (05-87)

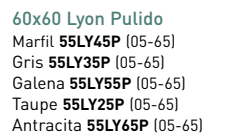

**60x60 Lyon Pulido**  
 Marfil **55LY45P** (05-65)  
 Gris **55LY35P** (05-65)  
 Galena **55LY55P** (05-65)  
 Taupe **55LY25P** (05-65)  
 Antracita **55LY65P** (05-65)



**30x60 Lyon Pulido**  
 Marfil **47LY42P** (05-63)  
 Gris **47LY32P** (05-63)  
 Galena **47LY52P** (05-63)  
 Taupe **47LY22P** (05-63)  
 Antracita **47LY62P** (05-63)

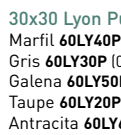

**30x30 Lyon Pulido**  
 Marfil **60LY40P** (05-20)  
 Gris **60LY30P** (05-20)  
 Galena **60LY50P** (05-20)  
 Taupe **60LY20P** (05-20)  
 Antracita **60LY60P** (05-20)



**20x80 Rodano**  
 Galena **08RO-56** (14-00)  
 Marfil **08RO-46** (14-00)  
 Gris **08RO-36** (14-00)  
 Taupe **08RO-26** (14-00)  
 Antracita **08RO-66** (14-00)



**30x30 Saona**  
 Galena **41LY50S** (13-71)  
 Marfil **41LY40S** (13-71)  
 Gris **41LY30S** (13-71)  
 Taupe **41LY20S** (13-71)  
 Antracita **41LY60S** (13-71)



**30x30 Bron**  
 Galena **41LY50B** (09-05)  
 Marfil **41LY40B** (09-05)  
 Gris **41LY30B** (09-05)  
 Taupe **41LY20B** (09-05)  
 Antracita **41LY60B** (09-05)



**15x15 Lyon Natural**  
 Marfil **06TLY40** (05-12)  
 Gris **06TLY30** (05-12)  
 Galena **06TLY50** (05-12)  
 Taupe **06TLY20** (05-12)  
 Antracita **06TLY60** (05-12)



**14,5x60 Lyon Natural**  
 Marfil **57LY42L** (05-57)  
 Gris **57LY32L** (05-57)  
 Galena **57LY52L** (05-57)  
 Taupe **57LY22L** (05-57)  
 Antracita **57LY62L** (05-57)



**9,7x60 Lyon Natural**  
 Marfil **57LY41D** (05-76)  
 Gris **57LY31D** (05-76)  
 Galena **57LY51D** (05-76)  
 Taupe **57LY21D** (05-76)  
 Antracita **57LY61D** (05-76)



**4,7x60 Lyon Natural**  
 Marfil **57LY45C** (05-90)  
 Gris **57LY35C** (05-90)  
 Galena **57LY55C** (05-90)  
 Taupe **57LY25C** (05-90)  
 Antracita **57LY65C** (05-90)

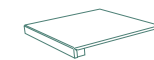

**Peldaño Escuadra**  
 30x30 (13-97)  
 30x60 (20-60)

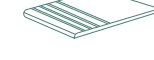

**Peldaño Escuadra Ángulo**  
 30x30 (20-60)  
 30x60 (20-70)



**Peldaño Porcelánico Romo Huella**  
 30x30 (12-80)  
 30x60 (13-70)



**Rodapié**  
 8x30 (11-60)  
 8x60 (12-65)  
 8x80 (13-04)

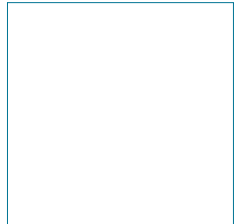

**60x60 Lyon 20MM Relieve** **20MM**  
 Gris **55LY320** (96-60)  
 Galena **55LY520** (96-60)  
 Taupe **55LY220** (96-60)

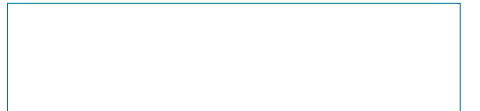

**30x120 Lyon 20MM Relieve** **20MM**  
 Gris **59LY39M** (96-70)  
 Galena **59LY59M** (96-70)  
 Taupe **59LY29M** (96-70)

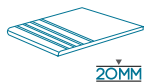

**Peldaño Porcelánico Romo Huella**  
 30x60 (13-81)  
 30x120 (20-14)

medida cm	nºpzax/box	m <sup>2</sup> /box	kg/box	boxes/pallet	m <sup>2</sup> /pallet	kg/pallet
30x120 20MM	2	0,72	33,50	20	14,40	670,00
60x60 20MM	2	0,73	33,50	32	23,36	1.072,00
80x80	2	1,28	34,25	40	51,20	1.370,00
40x80	3	0,96	26,75	30	28,80	802,50
60x60	3	1,08	25,75	32	34,56	824,00
30x60	6	1,08	24,80	40	43,20	992,00
30x30	9	0,81	18,45	48	38,88	885,60
15x15	20	0,45	7,80	100	-	-



METEOR 80X80 31<sup>1</sup>/<sub>2</sub>"X31<sup>1</sup>/<sub>2</sub>" 60X60 23<sup>5</sup>/<sub>8</sub>"X23<sup>5</sup>/<sub>8</sub>" 30X60 11<sup>13</sup>/<sub>16</sub>"X23<sup>5</sup>/<sub>8</sub>" 30X30 11<sup>13</sup>/<sub>16</sub>"X11<sup>13</sup>/<sub>16</sub>"  
15X15 5<sup>7</sup>/<sub>8</sub>" X5<sup>7</sup>/<sub>8</sub>"  
60X60 23<sup>5</sup>/<sub>8</sub>"X23<sup>5</sup>/<sub>8</sub>" **ISMM** 30X30 11<sup>13</sup>/<sub>16</sub>"X11<sup>13</sup>/<sub>16</sub>" **ISMM**

**T** PORCELÁNICO TÉCNICO / TODO MASA  
PORCELAIN TILES / FULL BODY



PORCELÁNICO TÉCNICO TODO MASA THROUGHBODY PORCELAIN TILES - FULL BODY



METEOR 80X80 31 1/2" X 31 1/2" 60X60 23 5/8" X 23 5/8" 30X60 11 13/16" X 23 5/8" 30X30 11 13/16" X 11 13/16"

T PORCELÁNICO TÉCNICO / TODO MASA  
PORCELAIN TILES / FULL BODY



15X15 5 7/8" X 5 7/8"

60X60 23 5/8" X 23 5/8" 15MM 30X30 11 13/16" X 11 13/16" 15MM

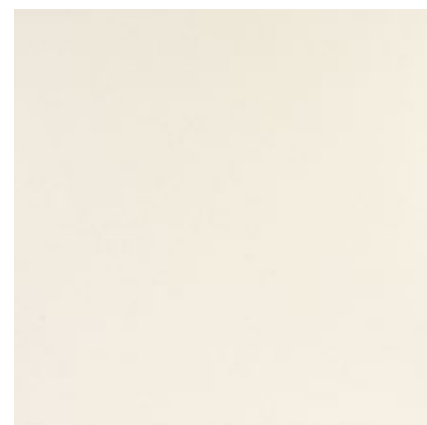

BLANCO

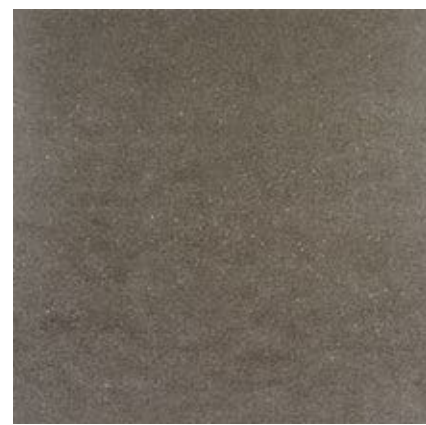

MOKA

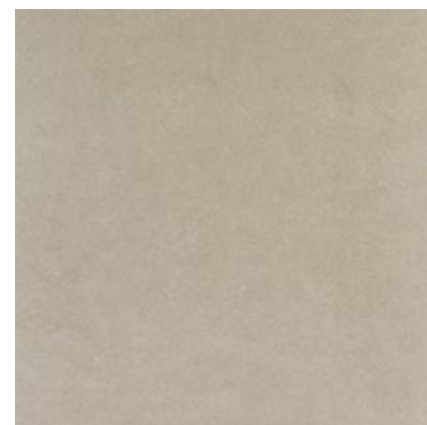

GRIS



MARENGO



ANTRACITA



NEGRO

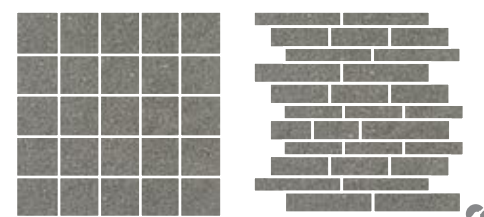

**30x30 Marte Natural**  
Blanco **41MT-40** (09-05)  
Moka **41MT-20** (09-05)  
Gris **41MT-30** (09-05)  
Marengo **41MT-50** (09-05)  
Antracita **41MT-60** (09-05)  
Negro **41MT-90** (09-05)

**30x30 Jupiter Natural**  
Blanco **41JU-40** (13-77)  
Moka **41JU-20** (13-77)  
Gris **41JU-30** (13-77)  
Marengo **41JU-50** (13-77)  
Antracita **41JU-60** (13-77)  
Negro **41JU-90** (13-77)

**30x30 Marte Relieve**  
Blanco **41MT40R** (09-05)  
Moka **41MT20R** (09-05)  
Gris **41MT30R** (09-05)  
Marengo **41MT50R** (09-05)  
Antracita **41MT60R** (09-05)  
Negro **41MT90R** (09-05)

**30x30 Jupiter Relieve**  
Blanco **41JU40R** (13-77)  
Moka **41JU20R** (13-77)  
Gris **41JU30R** (13-77)  
Marengo **41JU50R** (13-77)  
Antracita **41JU60R** (13-77)  
Negro **41JU90R** (13-77)

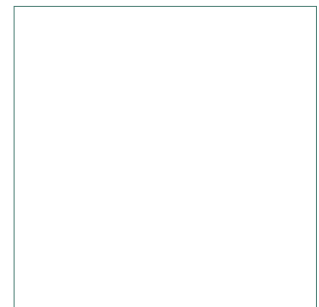

**80x80 Meteor Natural**  
Blanco **61ME-46** (05-79)  
Moka **61ME-26** (05-49)  
Gris **61ME-36** (05-49)  
Marengo **61ME-56** (05-49)  
Antracita **61ME-66** (05-49)  
Negro **61ME-96** (05-49)

**80x80 Meteor Pulido**  
Blanco **61ME46P** (05-83)  
Moka **61ME26P** (05-82)  
Gris **61ME36P** (05-82)  
Marengo **61ME56P** (05-82)  
Antracita **61ME66P** (05-82)  
Negro **61ME96P** (05-82)

**14,5x60 / 9,7x60 / 4,7x60 Mix Meteor**  
Blanco **57ME4MX** (05-84)  
Moka **57ME2MX** (05-84)  
Gris **57ME3MX** (05-84)  
Marengo **57ME5MX** (05-84)  
Antracita **57ME6MX** (05-84)  
Negro **57ME9MX** (05-84)



**60x60 Meteor Natural**  
Blanco **55ME-45** (05-59)  
Moka **55ME-25** (05-58)  
Gris **55ME-35** (05-58)  
Marengo **55ME-55** (05-58)  
Antracita **55ME-65** (05-58)  
Negro **55ME-95** (05-58)

**60x60 Meteor Pulido**  
Blanco **55ME45P** (05-66)  
Moka **55ME25P** (05-65)  
Gris **55ME35P** (05-65)  
Marengo **55ME55P** (05-65)  
Antracita **55ME65P** (05-65)  
Negro **55ME95P** (05-65)

**60x60 Meteor Relieve**  
Blanco **55ME45R** (05-59)  
Moka **55ME25R** (05-58)  
Gris **55ME35R** (05-58)  
Marengo **55ME55R** (05-58)  
Antracita **55ME65R** (05-58)  
Negro **55ME95R** (05-58)



**30x60 Meteor Natural**  
Blanco **47ME-42** (05-59)  
Moka **47ME-22** (05-58)  
Gris **47ME-32** (05-58)  
Marengo **47ME-52** (05-58)  
Antracita **47ME-62** (05-58)  
Negro **47ME-92** (05-58)

**30x60 Meteor Pulido**  
Blanco **47ME42P** (05-66)  
Moka **47ME22P** (05-65)  
Gris **47ME32P** (05-65)  
Marengo **47ME52P** (05-65)  
Antracita **47ME62P** (05-65)  
Negro **47ME92P** (05-65)

**30x60 Meteor Relieve**  
Blanco **47ME42R** (05-59)  
Moka **47ME22R** (05-58)  
Gris **47ME32R** (05-58)  
Marengo **47ME52R** (05-58)  
Antracita **47ME62R** (05-58)  
Negro **47ME92R** (05-58)

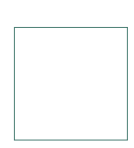

**30x30 Meteor Natural**  
Blanco **60ME-40** (05-16)  
Moka **60ME-20** (05-15)  
Gris **60ME-30** (05-15)  
Marengo **60ME-50** (05-15)  
Antracita **60ME-60** (05-15)  
Negro **60ME-90** (05-15)

**30x30 Meteor Pulido**  
Blanco **60ME40P** (04-79)  
Moka **60ME20P** (05-65)  
Gris **60ME30P** (04-78)  
Marengo **60ME50P** (04-78)  
Antracita **60ME60P** (04-78)  
Negro **60ME90P** (04-78)

**30x30 Meteor Relieve**  
Blanco **60ME40R** (05-16)  
Moka **60ME20R** (05-15)  
Gris **60ME30R** (05-15)  
Marengo **60ME50R** (05-15)  
Antracita **60ME60R** (05-15)  
Negro **60ME90R** (05-15)



**15x15 Meteor Natural**  
Blanco **06TME40** (05-12)  
Moka **06TME20** (05-12)  
Gris **06TME30** (05-12)  
Marengo **06TME50** (05-12)  
Antracita **06TME60** (05-12)  
Negro **06TME90** (05-12)

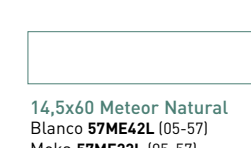

**14,5x60 Meteor Natural**  
Blanco **57ME42L** (05-57)  
Moka **57ME22L** (05-57)  
Gris **57ME32L** (05-57)  
Marengo **57ME52L** (05-57)  
Antracita **57ME62L** (05-57)  
Negro **57ME92L** (05-57)

**14,5x60 Meteor Pulido**  
Blanco **57ME4PL** (05-67)  
Moka **57ME2PL** (05-67)  
Gris **57ME3PL** (05-67)  
Marengo **57ME5PL** (05-67)  
Antracita **57ME6PL** (05-67)  
Negro **57ME9PL** (05-67)

**14,5x60 Meteor Relieve**  
Blanco **57ME4RL** (05-57)  
Moka **57ME2RL** (05-57)  
Gris **57ME3RL** (05-57)  
Marengo **57ME5RL** (05-57)  
Antracita **57ME6RL** (05-57)  
Negro **57ME9RL** (05-57)

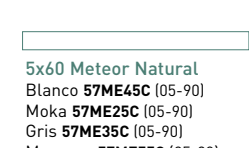

**5x60 Meteor Natural**  
Blanco **57ME45C** (05-90)  
Moka **57ME25C** (05-90)  
Gris **57ME35C** (05-90)  
Marengo **57ME55C** (05-90)  
Antracita **57ME65C** (05-90)  
Negro **57ME95C** (05-90)

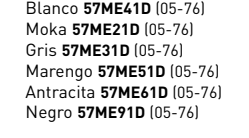

**10x60 Meteor Natural**  
Blanco **57ME41D** (05-76)  
Moka **57ME21D** (05-76)  
Gris **57ME31D** (05-76)  
Marengo **57ME51D** (05-76)  
Antracita **57ME61D** (05-76)  
Negro **57ME91D** (05-76)

Peldaño Escuadra Ang.  
30x30 (20-60)  
30x60 (20-70)

Peldaño Escuadra  
30x30 (13-97)  
30x60 (20-60)

Peldaño Porcelánico  
Romo Huella  
30x30 Natural y Relieve (12-80)  
30x30 Pulido (13-04)  
30x60 Natural y Relieve (13-70)  
30x60 Pulido (13-75)

Rodapié  
8x30 (11-60)  
8x60 (12-65)

medida cm	nºpzax/box	m²/box	kg/box	boxes/pallet	m²/pallet	kg/pallet
80x80	2	1,28	34,25	40	51,20	1.370,00
60x60	3	1,08	25,75	32	34,56	824,00
30x60	6	1,08	24,80	40	43,20	992,00
30x30	9	0,81	18,45	48	38,88	885,60
15x15	20	0,45	7,80	100	-	-
60x60 15MM	2	0,72	26,25	32	23,04	840,00
30x30 15MM	6	0,54	19,10	48	25,92	916,80
30x30 mallado	11	1,00	20,00	36	36,00	720,00



MONTREAL 80X80 31<sup>1</sup>/<sub>2</sub>"X31<sup>1</sup>/<sub>2</sub>" 60X60 23<sup>5</sup>/<sub>8</sub>"X23<sup>5</sup>/<sub>8</sub>" 30X60 11<sup>13</sup>/<sub>16</sub>"X23<sup>5</sup>/<sub>8</sub>" 30X30 11<sup>13</sup>/<sub>16</sub>"X11<sup>13</sup>/<sub>16</sub>"  
15X15 5<sup>7</sup>/<sub>8</sub>"X5<sup>7</sup>/<sub>8</sub>" 75X75 29<sup>17</sup>/<sub>32</sub>"X29<sup>17</sup>/<sub>32</sub>" 

 PORCELÁNICO TÉCNICO / TODO MASA  
PORCELAIN TILES / FULL BODY

NUEVO NEW

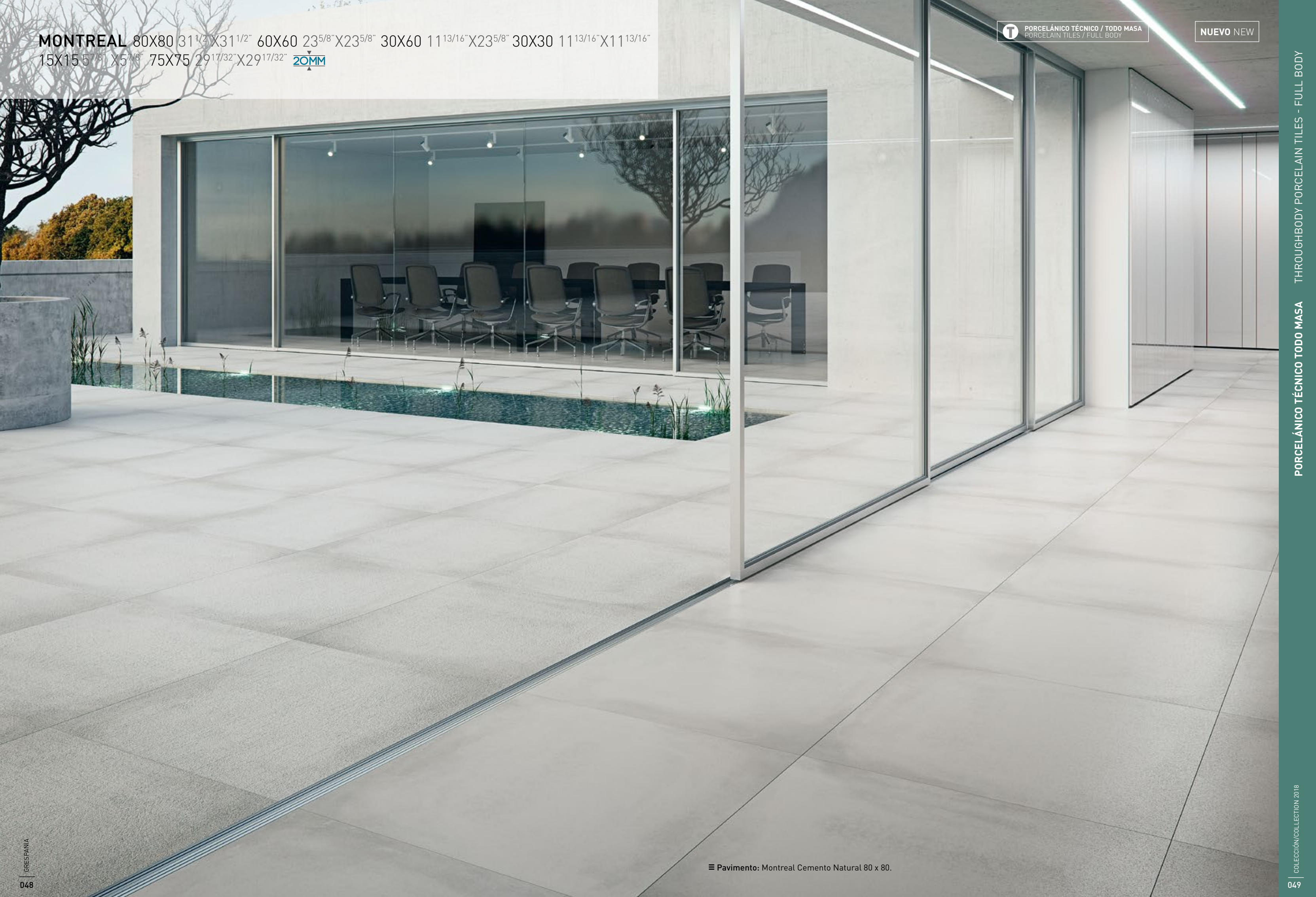

PORCELÁNICO TÉCNICO TODO MASA THROUGHBODY PORCELAIN TILES - FULL BODY

**MONTREAL** 80X80 31<sup>1</sup>/<sub>2</sub>"X31<sup>1</sup>/<sub>2</sub>" 60X60 23<sup>5</sup>/<sub>8</sub>"X23<sup>5</sup>/<sub>8</sub>" 30X60 11<sup>13</sup>/<sub>16</sub>"X23<sup>5</sup>/<sub>8</sub>" 30X30 11<sup>13</sup>/<sub>16</sub>"X11<sup>13</sup>/<sub>16</sub>"  
 15X15 5<sup>7</sup>/<sub>8</sub>" X5<sup>7</sup>/<sub>8</sub>" 75X75 29<sup>17</sup>/<sub>32</sub>"X29<sup>17</sup>/<sub>32</sub>" **ZOMM**

**T** PORCELÁNICO TÉCNICO / TODO MASA  
 PORCELAIN TILES / FULL BODY

**NUEVO NEW**



BLANCO



CEMENTO



GRIS



ANTRACITA

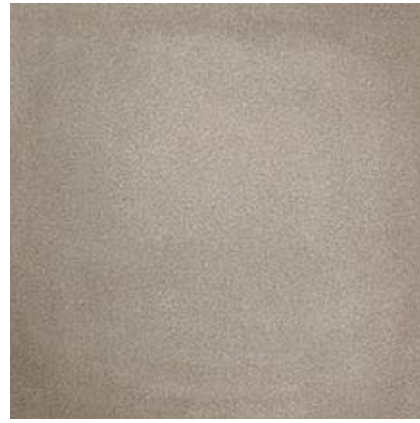

TAUPE

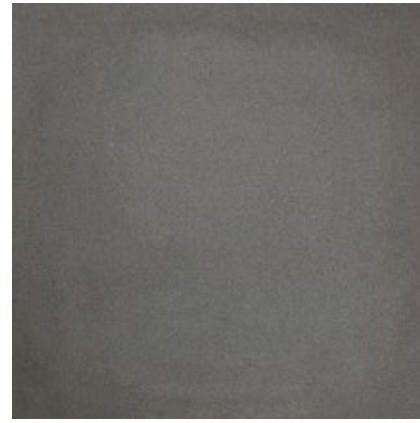

NEGRO

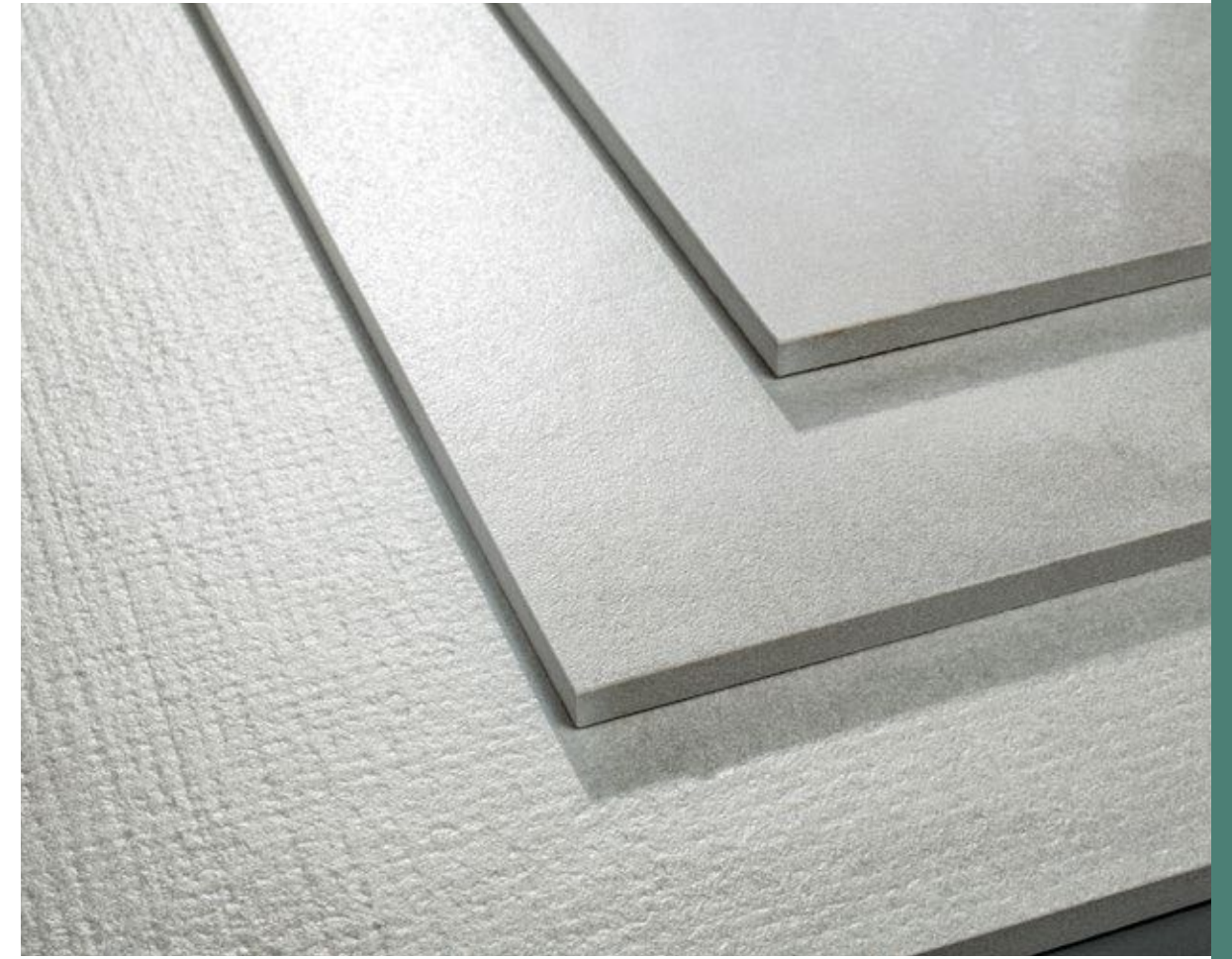

**80x80 Montreal Natural**  
 Blanco **61MT-46** [05-69]  
 Gris **61MT-36** [05-69]  
 Cemento **61MT-16** [05-69]  
 Taupé **61MT-26** [05-69]  
 Antracita **61MT-66** [05-69]  
 Negro **61MT-96** [05-69]



**60x60 Montreal Natural**  
 Blanco **55MT-45** [05-58]  
 Gris **55MT-35** [05-58]  
 Cemento **55MT-15** [05-58]  
 Taupé **55MT-25** [05-58]  
 Antracita **55MT-65** [05-58]  
 Negro **55MT-95** [05-58]



**30x60 Montreal Natural**  
 Blanco **47MT-42** [05-37]  
 Gris **47MT-32** [05-37]  
 Cemento **47MT-12** [05-37]  
 Taupé **47MT-22** [05-37]  
 Antracita **47MT-62** [05-37]  
 Negro **47MT-92** [05-37]



**30x30 Montreal Natural**  
 Blanco **60MT-40** [05-15]  
 Gris **60MT-30** [05-15]  
 Cemento **60MT-10** [05-15]  
 Taupé **60MT-20** [05-15]  
 Antracita **60MT-60** [05-15]  
 Negro **60MT-90** [05-15]



**15x15 Montreal Natural**  
 Blanco **06TMT40** [05-12]  
 Gris **06TMT30** [05-12]  
 Cemento **06TMT10** [05-12]  
 Taupé **06TMT20** [05-12]  
 Antracita **06TMT60** [05-12]  
 Negro **06TMT90** [05-12]

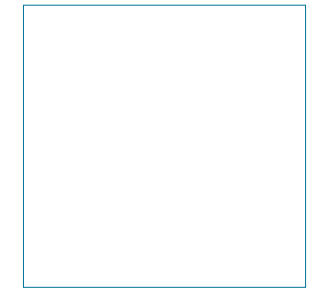

**75x75 Montreal 20MM**  
 Blanco **61MTE46** [96-65]  
 Gris **61MTE36** [96-65]  
 Cemento **61MTE16** [96-65]  
 Taupé **61MTE26** [96-65]  
 Antracita **61MTE66** [96-65]  
 Negro **61MTE96** [96-65]

**80x80 Montreal Pulido**  
 Blanco **61MT46P** [05-77]  
 Gris **61MT36P** [05-77]  
 Cemento **61MT16P** [05-77]  
 Taupé **61MT26P** [05-77]  
 Antracita **61MT66P** [05-77]  
 Negro **61MT96P** [05-77]

**60x60 Montreal Pulido**  
 Blanco **55MT45P** [05-65]  
 Gris **55MT35P** [05-65]  
 Cemento **55MT15P** [05-65]  
 Taupé **55MT25P** [05-65]  
 Antracita **55MT65P** [05-65]  
 Negro **55MT95P** [05-65]

**30x60 Montreal Pulido**  
 Blanco **47MT42P** [05-63]  
 Gris **47MT32P** [05-63]  
 Cemento **47MT12P** [05-63]  
 Taupé **47MT22P** [05-63]  
 Antracita **47MT62P** [05-63]  
 Negro **47MT92P** [05-63]

**30x30 Montreal Pulido**  
 Blanco **60MT40P** [05-20]  
 Gris **60MT30P** [05-20]  
 Cemento **60MT10P** [05-20]  
 Taupé **60MT20P** [05-20]  
 Antracita **60MT60P** [05-20]  
 Negro **60MT90P** [05-20]

**80x80 Montreal Relieve**  
 Blanco **61MT46R** [05-69]  
 Gris **61MT36R** [05-69]  
 Cemento **61MT16R** [05-69]  
 Taupé **61MT26R** [05-69]  
 Antracita **61MT66R** [05-69]  
 Negro **61MT96R** [05-69]

**60x60 Montreal Relieve**  
 Blanco **55MT45R** [05-58]  
 Gris **55MT35R** [05-58]  
 Cemento **55MT15R** [05-58]  
 Taupé **55MT25R** [05-58]  
 Antracita **55MT65R** [05-58]  
 Negro **55MT95R** [05-58]

**30x60 Montreal Relieve**  
 Blanco **47MT42R** [05-37]  
 Gris **47MT32R** [05-37]  
 Cemento **47MT12R** [05-37]  
 Taupé **47MT22R** [05-37]  
 Antracita **47MT62R** [05-37]  
 Negro **47MT92R** [05-37]

**30x30 Montreal Relieve**  
 Blanco **60MT40R** [05-15]  
 Gris **60MT30R** [05-15]  
 Cemento **60MT10R** [05-15]  
 Taupé **60MT20R** [05-15]  
 Antracita **60MT60R** [05-15]  
 Negro **60MT90R** [05-15]

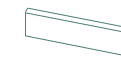

**Rodapié**  
 8x60 [12-65]  
 8x80 [13-04]

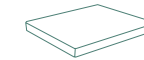

**Peldaño Escuadra Ang.**  
 30x30 [20-60]  
 30x80 [20-50]

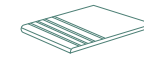

**Peldaño Porcelánico Romo Huella**  
 30x30 [12-80]  
 30x80 [18-00]

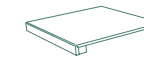

**Peldaño Escuadra**  
 30x30 [13-97]  
 30x80 [20-40]

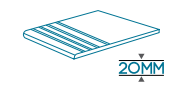

**Peldaño Porcelánico Romo Huella**  
 30x75 [18-00]

medida cm	nºpzax/box	m²/box	kg/box	boxes/pallet	m²/pallet	kg/pallet
80x80	2	1,28	34,25	40	51,20	1.370,00
60x60	3	1,08	25,75	32	34,56	824,00
30x60	6	1,08	24,80	40	43,20	992,00
30x30	9	0,81	18,45	48	38,88	885,60
15x15	20	0,45	7,80	100	-	-
75x75 20MM	1	0,56	24,91	42	23,63	1.046,22



11,3mm [80x80]  
 10mm [60x60/30x60/30x30/15x15]  
 20MM [75x75]

NEXO 80X80 31<sup>1</sup>/<sub>2</sub>"X31<sup>1</sup>/<sub>2</sub>" 60X60 23<sup>5</sup>/<sub>8</sub>"X23<sup>5</sup>/<sub>8</sub>" 30X60 11<sup>13</sup>/<sub>16</sub>"X23<sup>5</sup>/<sub>8</sub>" 30X30 11<sup>13</sup>/<sub>16</sub>"X11<sup>13</sup>/<sub>16</sub>"  
15X15 5<sup>7</sup>/<sub>8</sub>" X5<sup>7</sup>/<sub>8</sub>"

T PORCELÁNICO TÉCNICO / TODO MASA  
PORCELAIN TILES / FULL BODY



III Revestimiento: Nexo beige Natural 30 x 60.

III Pavimento: Nexo beige Pulido 60 x 60.

**NEXO** 80x80 31<sup>1/2</sup>"x31<sup>1/2</sup>" 60x60 23<sup>5/8</sup>"x23<sup>5/8</sup>" 30x60 11<sup>13/16</sup>"x23<sup>5/8</sup>" 30x30 11<sup>13/16</sup>"x11<sup>13/16</sup>"  
15x15 5<sup>7/8</sup>" x5<sup>7/8</sup>"

**T** PORCELÁNICO TÉCNICO / TODO MASA  
PORCELAIN TILES / FULL BODY



BLANCO



BEIGE



MARRÓN



GRIS



ANTRACITA



NEGRO

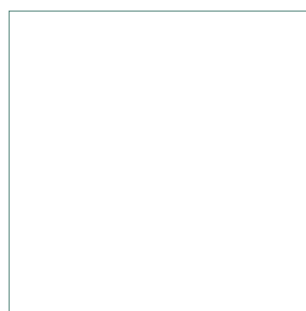
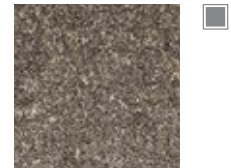
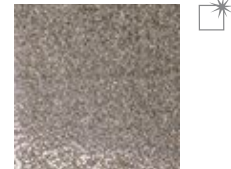

**80x80 Nexo Natural**  
Blanco **61NX-46** (05-79)  
Beige **61NX-76** (05-49)  
Marrón **61NX-26** (05-49)  
Gris **61NX-36** (05-49)  
Antracita **61NX-56** (05-49)  
Negro **61NX-96** (05-49)

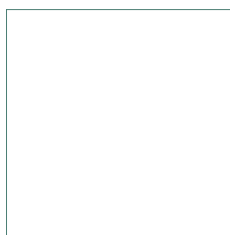

**60x60 Nexo Natural**  
Blanco **55NX-45** (05-59)  
Beige **55NX-75** (05-58)  
Marrón **55NX-25** (05-58)  
Gris **55NX-35** (05-58)  
Antracita **55NX-55** (05-58)  
Negro **55NX-95** (05-58)



**30x30 Nexo Natural**  
Blanco **60NX-40** (05-16)  
Beige **60NX-70** (05-15)  
Marrón **60NX-20** (05-15)  
Gris **60NX-30** (05-15)  
Antracita **60NX-50** (05-15)  
Negro **60NX-90** (05-15)

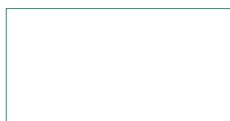

**30x60 Nexo Natural**  
Blanco **47NX-42** (05-38)  
Beige **47NX-72** (05-37)  
Marrón **47NX-22** (05-37)  
Gris **47NX-32** (05-37)  
Antracita **47NX-52** (05-37)  
Negro **47NX-92** (05-37)



**14,5x60 Nexo Natural**  
Blanco **57NX42L** (05-57)  
Beige **57NX72L** (05-57)  
Marrón **57NX22L** (05-57)  
Gris **57NX32L** (05-57)  
Antracita **57NX52L** (05-57)  
Negro **57NX92L** (05-57)

**80x80 Nexo Pulido**  
Blanco **61NXP46** (05-83)  
Beige **61NXP76** (05-82)  
Marrón **61NXP26** (05-82)  
Gris **61NXP36** (05-82)  
Antracita **61NXP56** (05-82)  
Negro **61NXP96** (05-82)

**60x60 Nexo Pulido**  
Blanco **55NXP45** (05-66)  
Beige **55NXP75** (05-65)  
Marrón **55NXP25** (05-65)  
Gris **55NXP35** (05-65)  
Antracita **55NXP55** (05-65)  
Negro **55NXP95** (05-65)

**30x30 Nexo Pulido**  
Blanco **60NXP40** (05-21)  
Beige **60NXP70** (05-20)  
Marrón **60NXP20** (05-20)  
Gris **60NXP30** (05-20)  
Antracita **60NXP50** (05-20)  
Negro **60NXP90** (05-20)

**30x60 Nexo Pulido**  
Blanco **47NXP42** (05-64)  
Beige **47NXP72** (05-63)  
Marrón **47NXP22** (05-63)  
Gris **47NXP32** (05-63)  
Antracita **47NXP52** (05-63)  
Negro **47NXP92** (05-63)

**14,5x60 Nexo Pulido**  
Blanco **57NX4PL** (05-67)  
Beige **57NX7PL** (05-67)  
Marrón **57NX2PL** (05-67)  
Gris **57NX3PL** (05-67)  
Antracita **57NX5PL** (05-67)  
Negro **57NX9PL** (05-67)

**60x60 Nexo Relieve**  
Blanco **55NXR45** (05-59)  
Beige **55NXR75** (05-58)  
Marrón **55NXR25** (05-58)  
Gris **55NXR35** (05-58)  
Antracita **55NXR55** (05-58)  
Negro **55NXR95** (05-58)

**30x30 Nexo Relieve**  
Blanco **47NXR42** (05-37)  
Beige **47NXR72** (05-37)  
Marrón **47NXR22** (05-37)  
Gris **47NXR32** (05-37)  
Antracita **47NXR52** (05-37)  
Negro **47NXR92** (05-37)

**30x60 Nexo Relieve**  
Blanco **47NXR42** (05-38)  
Beige **47NXR72** (05-37)  
Marrón **47NXR22** (05-37)  
Gris **47NXR32** (05-37)  
Antracita **47NXR52** (05-37)  
Negro **47NXR92** (05-37)

**14,5x60 Nexo Relieve**  
Blanco **57NX4RL** (05-57)  
Beige **57NX7RL** (05-57)  
Marrón **57NX2RL** (05-57)  
Gris **57NX3RL** (05-57)  
Antracita **57NX5RL** (05-57)  
Negro **57NX9RL** (05-57)



**15x15 Nexo Natural**  
Blanco **06TNX40** (05-12)  
Beige **06TNX70** (05-12)  
Marrón **06TNX20** (05-12)  
Gris **06TNX30** (05-12)  
Antracita **06TNX50** (05-12)  
Negro **06TNX90** (05-12)



**10x60 Nexo Natural**  
Blanco **57NX41D** (05-76)  
Beige **57NX71D** (05-76)  
Marrón **57NX21D** (05-76)  
Gris **57NX31D** (05-76)  
Antracita **57NX51D** (05-76)  
Negro **57NX91D** (05-76)



**5x60 Nexo Natural**  
Blanco **57NX45C** (05-90)  
Beige **57NX75C** (05-90)  
Marrón **57NX25C** (05-90)  
Gris **57NX35C** (05-90)  
Antracita **57NX55C** (05-90)  
Negro **57NX95C** (05-90)

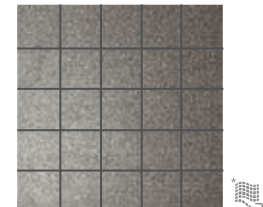

**30x30 Noam**  
Antracita **41NO-50** (09-05)  
Blanco **41NO-40** (09-05)  
Beige **41NO-70** (09-05)  
Marrón **41NO-20** (09-05)  
Gris **41NO-30** (09-05)  
Negro **41NO-90** (09-05)



**30x30 Union**  
Antracita **41UN-50** (13-15)  
Blanco **41UN-40** (13-15)  
Beige **41UN-70** (13-15)  
Marrón **41UN-20** (13-15)  
Gris **41UN-30** (13-15)  
Negro **41UN-90** (13-15)



**28x28 Solido**  
Antracita **41SD-50** (13-80)  
Blanco **41SD-40** (13-80)  
Beige **41SD-70** (13-80)  
Marrón **41SD-20** (13-80)  
Gris **41SD-30** (13-80)  
Negro **41SD-90** (13-80)



**30x30 Matrix**  
Gris **41MX-30** (13-30)



**30x30 Matrix**  
Marrón **41MX-20** (13-30)



**Peldaño Porcelánico Romo Huella**  
30x30 Natural y Relieve (12-80) / Pulido (13-04)  
30x60 Natural y Relieve (13-70) / Pulido (13-75)



**Peldaño Escuadra**  
30x30 (13-97)  
30x60 (20-60)



**Peldaño Escuadra Ang.**  
30x30 (20-60)  
30x60 (20-70)

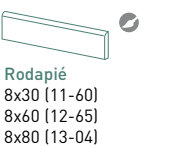

**Rodapié**  
8x30 (11-60)  
8x60 (12-65)  
8x80 (13-04)

medida cm	nºpzax/box	m²/box	kg/box	boxes/pallet	m²/pallet	kg/pallet
80x80	2	1,28	34,25	40	51,20	1.370,00
60x60	3	1,08	25,75	32	34,56	824,00
30x60	6	1,08	24,80	40	43,20	992,00
30x30	9	0,81	18,45	48	38,88	885,60
15x15	20	0,45	7,80	100	-	-

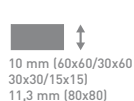

STARK 60X120 23<sup>5/8</sup>"X 47<sup>11/16</sup>" 60X60 23<sup>5/8</sup>"X23<sup>5/8</sup>" 60X60 23<sup>5/8</sup>"X23<sup>5/8</sup>" 15MM

T PORCELÁNICO TÉCNICO / TODO MASA  
PORCELAIN TILES / FULL BODY

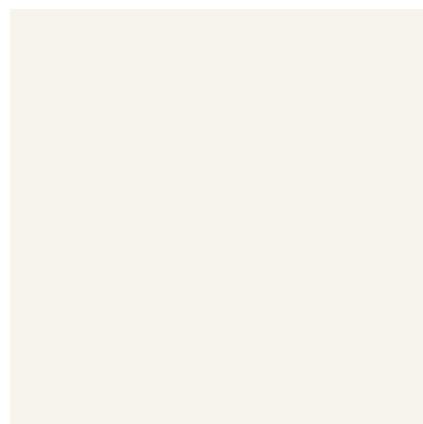

BLANCO

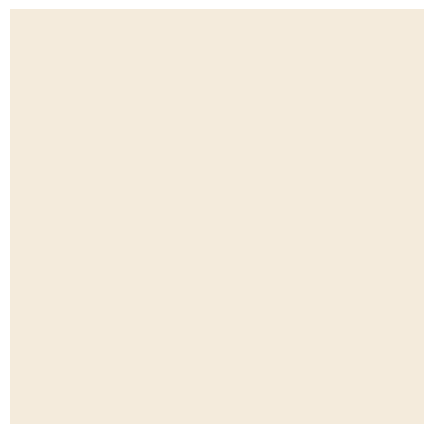

MARFIL

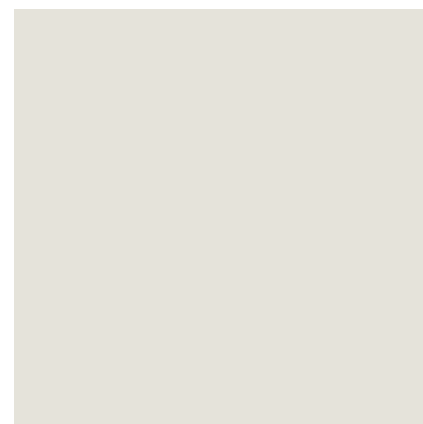

CEMENTO



TAUPE

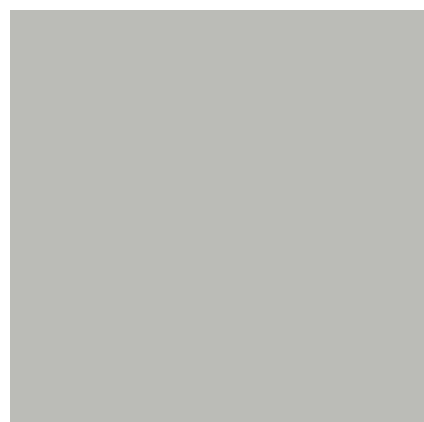

GRIS



MARENGO

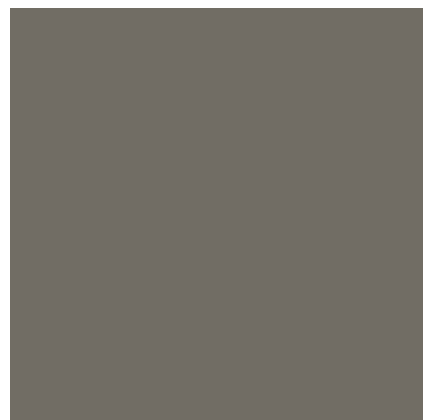

ANTRACITA



NEGRO

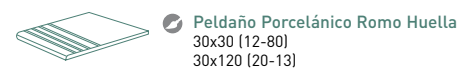

Peldaño Porcelánico Romo Huella  
30x30 [12-80]  
30x120 [20-13]



Peldaño Escuadra  
30x30 [13-97]  
30x120 [20-80]



Peldaño Escuadra Ang.  
30x30 [20-60]  
30x120 [20-90]



Rodapié  
8x60 [12-46]

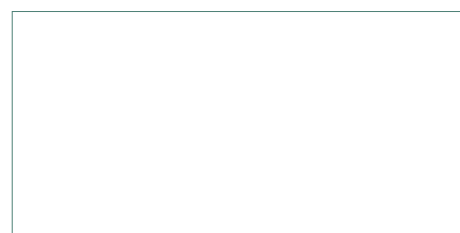

60x120 Stark  
Blanco **52RK49R** (08-10)  
Marfil **52RK79R** (08-08)  
Cemento **52RK19R** (08-08)  
Taupe **52RK29R** (08-08)  
Gris **52RK39R** (08-08)  
Marengo **52RK59R** (08-08)  
Antracita **52RK69R** (08-08)  
Negro **52RK99R** (08-08)

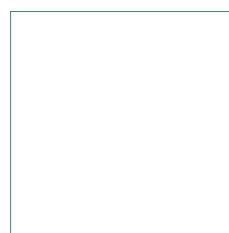

60x60 Stark  
Blanco **52RK45R** (05-26)  
Marfil **52RK75R** (05-25)  
Cemento **52RK15R** (05-25)  
Taupe **52RK25R** (05-25)  
Gris **52RK35R** (05-25)  
Marengo **52RK55R** (05-25)  
Antracita **52RK65R** (05-25)  
Negro **52RK95R** (05-25)

60x60 Stark 15MM  
Blanco **55RK45E** (04-82)  
Marfil **55RK75E** (04-81)  
Cemento **55RK15E** (04-81)  
Taupe **55RK25E** (04-81)  
Gris **55RK35E** (04-81)  
Marengo **55RK55E** (04-81)  
Antracita **55RK65E** (04-81)  
Negro **55RK95E** (04-81)



III Revestimiento: Stark Blanco 60 x 120, Stark Taupe 60 x 120. P Pavimento: Lyon Gris 20MM 60 x 60, Lyon gris 20MM 60 x 120.

medida cm	nº pzas/box	m <sup>2</sup> /box	kg/box	boxes/pallet	m <sup>2</sup> /pallet	kg/pallet
60x120	2	1,44	38,50	25	36,00	962,50
60x60	3	1,08	25,75	32	34,56	824,00
60x60 15MM	2	0,72	26,25	32	23,04	840,00



**TITAN 120X60 47<sup>11/16</sup>"X23<sup>5/8</sup>" 60X60 23<sup>5/8</sup>"X23<sup>5/8</sup>"**

**T** PORCELÁNICO TÉCNICO / TODO MASA  
PORCELAIN TILES / FULL BODY



GRIS



CEMENTO



ANTRACITA

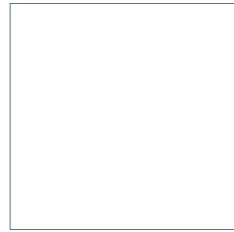

60x60 Titan  
Gris **52TI35R** (05-39)  
Cemento **52TI15R** (05-39)  
Antracita **52TI55R** (05-39)

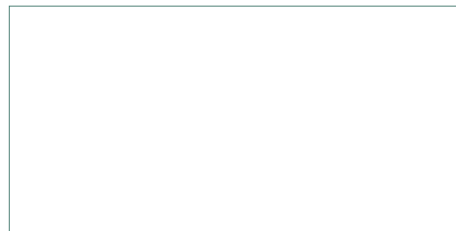

120x60 Titan  
Gris **58TI39R** (08-12)  
Cemento **58TI19R** (08-12)  
Antracita **58TI59R** (08-12)

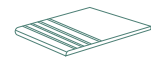

● Peldaño Porcelánico Romo Huella  
30x30 (12-80)  
30x120 (20-13)

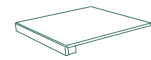

● Peldaño Escuadra  
30x30 (13-97)  
30x120 (20-80)

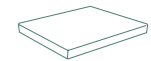

● Peldaño Escuadra Ang.  
30x30 (20-60)  
30x120 (20-90)

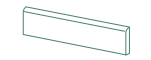

● Rodapié  
8x60 (12-46)



III Revestimiento: Titan Antracita 120 x 60.  
III Pavimento: Caucaso 20MM Cemento 60,5 x 60,5.



10 mm (60x60)  
11,3 mm (60x120)



medio



medida cm	nº pzas/box	m <sup>2</sup> /box	kg/box	boxes/pallet	m <sup>2</sup> /pallet	kg/pallet
60x120	2	1,44	38,50	25	36,00	962,50
60x60	3	1,08	25,75	32	34,56	824,00

# PORCELÁNICO PORCELAIN TILES

GRÈS CÉRAMÉ  
FEINSTEINZEUG  
PORCELLANATO  
GRES PORCELANOWY  
PORSELEINEN TEGELS  
КЕРАМОГРАНИТ

## 7X28 2<sup>3</sup>/<sub>4</sub>" X 11<sup>1</sup>/<sub>32</sub>"

AVALON	074
--------	-----

## 15X15 5<sup>7</sup>/<sub>8</sub>" X 5<sup>7</sup>/<sub>8</sub>"

ABADÍA	062
AVALON	074
AVENUE	078
VULCANO	178

## 15X80 5<sup>7</sup>/<sub>8</sub>" X 31<sup>1</sup>/<sub>2</sub>"

AMAZONIA	068
CAMBRIDGE	096
CAVA	104
SHERWOOD	162

## 29,5X120 11<sup>39</sup>/<sub>64</sub>" X 47<sup>11</sup>/<sub>16</sub>"

CAMBRIDGE	096
CAVA	104

## 30X30 11<sup>13</sup>/<sub>16</sub>" X 11<sup>13</sup>/<sub>16</sub>"

ABADÍA	062
BELLVER	084
ICARIA	128
KANSAS	278
REIMS	320
SINTRA	170

## 45X45 17<sup>3</sup>/<sub>4</sub>" X 17<sup>3</sup>/<sub>4</sub>"

BELLVER	084
BOSTON	088
COLUMBIA 45	282
CRETA	286
DOCK	112
HOMESTONE	126
ICARIA	128
MILAN	298
NEPAL	275
SINTRA	170
SKYLINE	172

## 60X60 23<sup>5</sup>/<sub>8</sub>" X 23<sup>5</sup>/<sub>8</sub>"

ALTAI	064
ATLAS	070
AUSTIN	199
AVALON	074
AVENUE	078
BASEL	194
BILBAO	086
BOSTON	088
CALACATA	092
CRETA	286
DOCK	112
ESCORIAL	114 <b>N</b>
ESTUCO	260
GALA	206
GEA	118
HABANA	122 <b>N</b>
HOMESTONE	126
ICARIA	128
KATMANDU	130
LIEJA	132
LORD	267
PRAGA	240
SIDNEY	166 <b>N</b>
SKYLINE	172
TEMPO	174
VULCANO	178
WABI CONCRETE	241 <b>N</b>

## 78X78 30<sup>3</sup>/<sub>4</sub>" X 30<sup>3</sup>/<sub>4</sub>"

PALACE	134 <b>N</b>
--------	--------------

## 9,5X28 3<sup>15</sup>/<sub>16</sub>" X 11<sup>7</sup>/<sub>32</sub>"

PALACE	134 <b>N</b>
--------	--------------

## 15X30 5<sup>7</sup>/<sub>8</sub>" X 11<sup>13</sup>/<sub>16</sub>"

ABADÍA	062
--------	-----

## 22X90 8<sup>11</sup>/<sub>16</sub>" X 35<sup>7</sup>/<sub>8</sub>"

ATLAS	070
BASILEA	082

## 19,5X120 7<sup>10</sup>/<sub>16</sub>" X 47<sup>11</sup>/<sub>16</sub>"

CAMBRIDGE	096
CAVA	104
CUBANA	110
PATAGONIA	160
SHERWOOD	162

## 30X60 11<sup>13</sup>/<sub>16</sub>" X 23<sup>5</sup>/<sub>8</sub>"

ALTAI	064
ATLAS	070
AVENUE	078
BELLVER	084
BILBAO	086
CALACATA	092
DOCK	112
HOMESTONE	126
ICARIA	128
KATMANDU	130
MELTEMI	312
SINTRA	170
SKYLINE	172
TEMPO	174

## 59X59 23<sup>1</sup>/<sub>4</sub>" X 23<sup>1</sup>/<sub>4</sub>"

ALTAI	064
PALACE	134 <b>N</b>

## 80X80 31<sup>1</sup>/<sub>2</sub>" X 31<sup>1</sup>/<sub>2</sub>"

AVALON	074
AVENUE	078
BOSTON	088
ESCORIAL	114 <b>N</b>
GEA	118
HABANA	122 <b>N</b>
SIDNEY	166 <b>N</b>
TEMPO	174
VULCANO	178

## 10X30 3<sup>15</sup>/<sub>16</sub>" X 11<sup>13</sup>/<sub>16</sub>"

CALACATA	092
----------	-----

## 15X60 5<sup>7</sup>/<sub>8</sub>" X 23<sup>5</sup>/<sub>8</sub>"

CANAIMA	102
---------	-----

## 28X59 11<sup>7</sup>/<sub>32</sub>" X 23<sup>1</sup>/<sub>4</sub>"

ALTAI	064
-------	-----

## 14,5X120 5<sup>23</sup>/<sub>32</sub>" X 47<sup>11</sup>/<sub>16</sub>"

CAMBRIDGE	096
CAVA	104
CUBANA	110
PATAGONIA	160
SHERWOOD	162

## 40X80 15<sup>4</sup>/<sub>4</sub>" X 31<sup>1</sup>/<sub>2</sub>"

AVALON	074
BOSTON	088
VULCANO	178

## 45X90 17<sup>3</sup>/<sub>4</sub>" X 35<sup>7</sup>/<sub>16</sub>"

ATLAS	070
BASILEA	082
BELLVER	084
BILBAO	086
HOMESTONE	126
SKYLINE	172

## 59X119 23<sup>1</sup>/<sub>4</sub>" X 46<sup>7</sup>/<sub>8</sub>"

PALACE	134 <b>N</b>
--------	--------------

## 60X120 47<sup>11</sup>/<sub>16</sub>" X 23<sup>5</sup>/<sub>8</sub>"

CALACATA	092
GEA	118
HABANA	122 <b>N</b>



nuevo · new · nouveau  
neu · nuovo · nowość nieuw  
· новое



ABADÍA 30X30 11<sup>13/16</sup>"X11<sup>13/16</sup>" 15X30 5<sup>7/8</sup>"X11<sup>13/16</sup>" 15X15 5<sup>7/8</sup>"X5<sup>7/8</sup>"



ROJO

IV



FUEGO

IV



SALMÓN

IV



BLANCO

IV



≡ Pavimento: Abadía Salmón 15 x 30.



≡ Pavimento: Abadía Rojo 30 x 30, Rectoría 5 x 30.



30x30 Nartex  
Blanco **41NX-40** (09-05)  
Fuego **41NX-80** (09-05)  
Salmón **41NX-70** (09-05)  
Rojo **41NX-20** (09-05)



5x30 Monasterio  
Blanco **06AB41M** (11-71)  
Fuego **06AB81M** (11-71)  
Salmón **06AB71M** (11-71)  
Rojo **06AB21M** (11-71)



5x30 Rectoría 30  
**06RE-30** (12-50)



30x30 Abadía  
Rojo **41AB-20** (02-51)  
Fuego **41AB-80** (02-51)  
Salmón **41AB-70** (02-51)  
Blanco **41AB-40** (02-51)

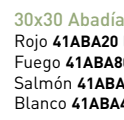

30x30 Abadía Antislip  
Rojo **41ABA20** (04-02)  
Fuego **41ABA80** (04-02)  
Salmón **41ABA70** (04-02)  
Blanco **41ABA40** (04-02)



15x30 L. Abadía  
Rojo **06LAB20** (05-10)  
Fuego **06LAB80** (05-10)  
Salmón **06LAB70** (05-10)  
Blanco **06LAB40** (05-10)



15x15 T. Abadía  
Rojo **06TAB20** (06-00)  
Fuego **06TAB80** (06-00)  
Salmón **06TAB70** (06-00)  
Blanco **06TAB40** (06-00)

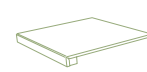

Peldaño Escuadra  
30 x 30 (13-97)

Peldaño Escuadra  
Antislip  
30 x 30 (13-97)

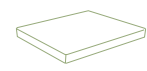

Peldaño Escuadra Ang.  
30 x 30 (20-60)

Peldaño Escuadra Ang.  
Antislip  
30 x 30 (20-60)



Rodapié  
8 x 30 (10-65)



≡ Pavimento: Abadía Fuego 30 x 30 / 15 x 30 / 15 x 15.

medida cm	nºpzax/box	m²/box	kg/box	boxes/pallet	m²/pallet	kg/pallet
30x30	10	0,90	20,70	48	43,20	993,60
30x30 mallado	11	1,00	20,00	36	36,00	720,00
15x30	10	0,45	7,80	100	45,00	780,00
15x15	20	0,45	7,80	100	45,00	780,00



10 mm



R9  
C1  
natural



R11  
C2  
antislip



A



alto



3mm

ALTAI 60X60 23<sup>5/8</sup>"X23<sup>5/8</sup>" 30X60 11<sup>13/16</sup>"X23<sup>5/8</sup>" 59X59 23<sup>1/4</sup>"X23<sup>1/4</sup>" 28X59 11<sup>7/32</sup>"X23<sup>1/4</sup>"



≡ Pavimento: Altai Pulido Gris 59 x 59.

ALTAI 60X60 23<sup>5/8</sup>"X23<sup>5/8</sup>" 30X60 11<sup>13/16</sup>"X23<sup>5/8</sup>" 59X59 23<sup>1/4</sup>"X23<sup>1/4</sup>" 28X59 11<sup>7/32</sup>"X23<sup>1/4</sup>"



MARFIL V



BEIGE V



30x30 Belukha  
Marfil 41TL40B (09-05)  
Beige 41TL70B (09-05)  
Blanco 41TL00B(09-05)  
Gris 41TL30B (09-05)



BLANCO V



GRIS IV

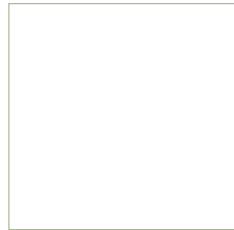

60x60 Altai Natural  
Marfil 52TL45R (07-83) V  
Beige 52TL75R (07-83) V  
Blanco 52TL05R (07-83) V  
Gris 52TL35R (07-83) IV

59x59 Altai Pulido  
Marfil 52TL45P (07-93) V  
Beige 52TL75P (07-93) V  
Blanco 52TL05P (07-93) IV  
Gris 52TL35P (07-93) IV



30X60 Altai Natural  
Marfil 46TL42R (07-79) V  
Beige 46TL72R (07-79) V  
Blanco 46TL02R (07-79) V  
Gris 46TL32R (07-79) IV

28x59 Altai Pulido  
Marfil 46TL42P (07-93) V  
Beige 46TL72P (07-93) V  
Blanco 46TL02P (07-93) IV  
Gris 46TL32P (07-93) IV



Peldaño Escuadra  
30x30 (13-97)  
30x60 (20-60)

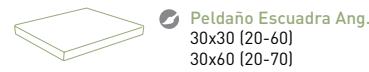

Peldaño Escuadra Ang.  
30x30 (20-60)  
30x60 (20-70)



Rodapié  
8x60 (12-46)



III Revestimiento: Altai Natural Beige 30 x 60, Gobi Beige 30 x 60.



30x60 Gobi  
Marfil 46TL412 (07-83)  
Beige 46TL712 (07-83)  
Blanco 46TL012 (07-83)  
Gris 46TL312 (07-83)



30X60 Sayannes  
Marfil 46TL422 (07-83)  
Beige 46TL722 (07-83)  
Blanco 46TL022 (07-83)  
Gris 46TL322 (07-83)

medida cm	nºpzax/box	m²/box	kg/box	boxes/pallet	m²/pallet	kg/pallet
60x60	3	1,08	25,75	32	34,56	824,00
59x59	3	1,04	25,75	32	33,28	824,00
30x60	6	1,08	24,80	40	43,20	992,00
28x59	6	0,99	23,25	40	39,60	930,00



# AMAZONIA 15X80 5<sup>7</sup>/<sub>8</sub>"X31<sup>1</sup>/<sub>2</sub>"



FRESNO IV



ROBLE IV



CASTAÑO IV



AZAHAR IV



ENCINA IV



ÉBANO IV



15x80 Recife IV

- Fresno **50RE-51** (00-95)
- Roble **50RE-71** (00-95)
- Castaño **50RE-81** (00-95)
- Azahar **50RE-41** (00-95)
- Encina **50RE-11** (00-95)
- Ébano **50RE-91** (00-95)



- 15x80 Amazonia
- Fresno **50AM-51** (00-90)
- Roble **50AM-71** (00-90)
- Castaño **50AM-81** (00-90)
- Azahar **50AM-41** (00-90)
- Encina **50AM-11** (00-90)
- Ébano **50AM-91** (00-90)



- 15x80 Amazonia Antislip
- Fresno **50AMA51** (00-95)
- Roble **50AMA71** (00-95)
- Castaño **50AMA81** (00-95)
- Azahar **50AMA41** (00-95)
- Encina **50AMA11** (00-95)
- Ébano **50AMA91** (00-95)



Rodapié 8 x 30 (10-65)



- 45x45 Bahia IV
- Fresno **42BA-58** (00-92)
- Roble **42BA-78** (00-92)
- Castaño **42BA-88** (00-92)
- Azahar **42BA-48** (00-92)
- Encina **42BA-18** (00-92)
- Ébano **42BA-98** (00-92)



Pavimento: Amazonia Fresno 15 x 80.

medida cm	nºpzax/box	m²/box	kg/box	boxes/pallet	m²/pallet	kg/pallet
15x80	9	1,08	26,00	48	51,84	1.248,00



10 mm



antislip Recife/Bahia



natural



medio



2mm



ATLAS 45X90 17<sup>3/4</sup>"X35<sup>7/6</sup>" 22X90 8<sup>11/16</sup>"X35<sup>7/6</sup>" 60X60 23<sup>5/8</sup>"X23<sup>5/8</sup>" 30X60 11<sup>13/16</sup>"X23<sup>5/8</sup>"  
45X90 17<sup>3/4</sup>"X35<sup>7/6</sup>" ZOMM



≡ Pavimento: Atlas Negro Natural 45 x 90 / 22 x 90.

ATLAS 45X90 17<sup>3</sup>/<sub>4</sub>"X35<sup>7</sup>/<sub>6</sub>" 22X90 8<sup>11</sup>/<sub>16</sub>"X35<sup>7</sup>/<sub>6</sub>" 60X60 23<sup>5</sup>/<sub>8</sub>"X23<sup>5</sup>/<sub>8</sub>" 30X60 11<sup>13</sup>/<sub>16</sub>"X23<sup>5</sup>/<sub>8</sub>"  
 45X90 17<sup>3</sup>/<sub>4</sub>"X35<sup>7</sup>/<sub>6</sub>" **20MM**



BLANCO

IV



BEIGE

IV



NEGRO

IV



GRIS

IV

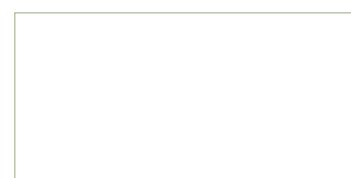
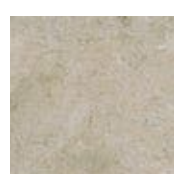
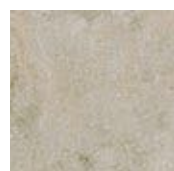

45x90 Atlas Pulido  
 Blanco 54AT47P (08-60)  
 Beige 54AT77P (08-60)  
 Gris 54AT37P (08-60)  
 Negro 54AT97P (08-60)

45x90 Atlas Natural  
 Blanco 54AT47R (08-09)  
 Beige 54AT77R (08-09)  
 Gris 54AT37R (08-09)  
 Negro 54AT97R (08-09)

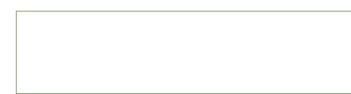

22x90 Atlas Pulido  
 Blanco 56AT4LP (08-60)  
 Beige 56AT7LP (08-60)  
 Gris 56AT3LP (08-60)  
 Negro 56AT9LP (08-60)

22x90 Atlas Natural  
 Blanco 56AT47L (08-09)  
 Beige 56AT77L (08-09)  
 Gris 56AT37L (08-09)  
 Negro 56AT97L (08-09)

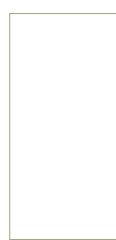

30x60 Atlas Pulido  
 Blanco 46TA42P (07-87)  
 Beige 46TA72P (07-87)  
 Gris 46TA32P (07-87)  
 Negro 46TA92P (07-87)

30x60 Atlas Natural  
 Blanco 46TA-42 (07-75)  
 Beige 46TA-72 (07-75)  
 Gris 46TA-32 (07-75)  
 Negro 46TA-92 (07-75)



60x60 Atlas Pulido  
 Blanco 52TA45P (07-94)  
 Beige 52TA75P (07-94)  
 Gris 52TA35P (07-94)  
 Negro 52TA95P (07-94)

60x60 Atlas Natural  
 Blanco 52TA45R (08-05)  
 Beige 52TA75R (08-05)  
 Gris 52TA35R (08-05)  
 Negro 52TA95R (08-05)

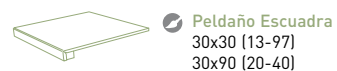

Peldaño Escuadra  
 30x30 (13-97)  
 30x90 (20-40)



Peldaño Escuadra Ang.  
 30x30 (20-60)  
 30x90 (20-50)



Rodapié  
 8x45 (11-81)  
 8x60 (12-46)

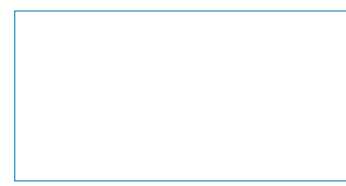

45x90 Atlas 20MM  
 Beige 54AT77E (96-65)  
 Gris 54AT37E (96-65)  
 Negro 54AT97E (96-65)



Peldaño Porcelánico Romo Huella  
 30x90 (20-10)



Pavimento: Atlas Beige Pulido 22 x 90.

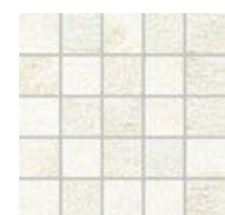

30x30 Sahel  
 Blanco 41HE-40 (09-05)

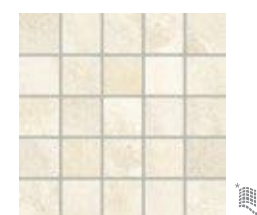

30x30 Sahel  
 Beige 41HE-70 (09-05)



30x30 Sahel  
 Gris 41HE-30 (09-05)



30x30 Sahel  
 Negro 41HE-90 (09-05)



22x22 Tubqal  
 Blanco 6TUB42 (13-72)



22x22 Tubqal  
 Beige 6TUB72 (13-72)





22x22 Tubqal  
 Gris 6TUB32 (13-72)

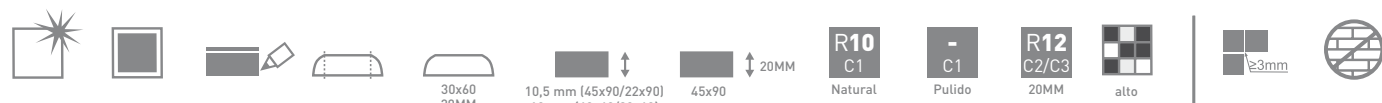

22x22 Tubqal  
 Negro 6TUB92 (13-72)

medida cm	nºpzax/box	m²/box	kg/box	boxes/pallet	m²/pallet	kg/pallet
45x90	3	1,22	30,50	27	32,94	823,50
22x90	5	1,00	25,00	54	54,00	1.350,20
45x90 20MM	2	0,81	36,23	24	19,44	869,52
60x60	3	1,08	25,75	32	34,56	824,00
30x60	6	1,08	25,80	40	43,20	1.032,00



**AVALON** 80X80 31<sup>1</sup>/<sub>2</sub>"X31<sup>1</sup>/<sub>2</sub>" 60X60 23<sup>5</sup>/<sub>8</sub>"X23<sup>5</sup>/<sub>8</sub>" 40X80 15<sup>6</sup>/<sub>4</sub>"X31<sup>1</sup>/<sub>2</sub>" 7X28 2<sup>3</sup>/<sub>4</sub>"X11<sup>1</sup>/<sub>32</sub>"  
15X15 5<sup>7</sup>/<sub>8</sub>" X5<sup>7</sup>/<sub>8</sub>"  
60,3X60,3 23<sup>3</sup>/<sub>4</sub>"X23<sup>3</sup>/<sub>4</sub>" 

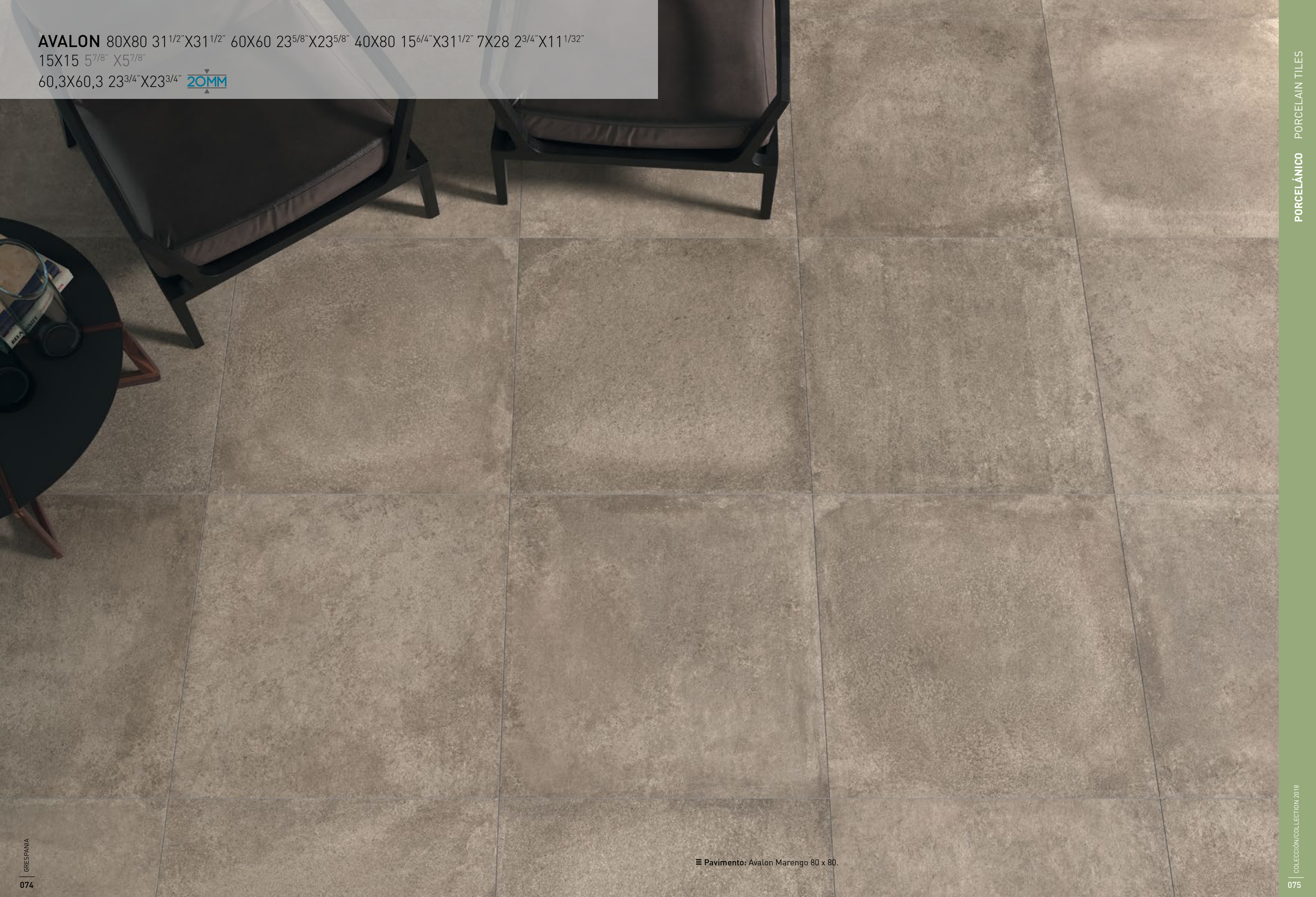

**AVALON** 80X80 31<sup>1</sup>/<sub>2</sub>"X31<sup>1</sup>/<sub>2</sub>" 60X60 23<sup>5</sup>/<sub>8</sub>"X23<sup>5</sup>/<sub>8</sub>" 40X80 15<sup>6</sup>/<sub>4</sub>"X31<sup>1</sup>/<sub>2</sub>" 7X28 2<sup>3</sup>/<sub>4</sub>"X11<sup>1</sup>/<sub>32</sub>"  
 15X15 5<sup>7</sup>/<sub>8</sub>" X5<sup>7</sup>/<sub>8</sub>"  
 60,3X60,3 23<sup>3</sup>/<sub>4</sub>"X23<sup>3</sup>/<sub>4</sub>" **20MM**



BLANCO

IV



CEMENTO

IV

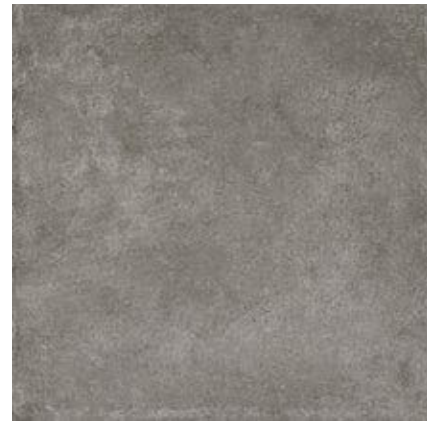

ANTRACITA

IV



TAUPÉ

IV



MARENGO

IV



II Pavimento: Avalon Cemento 80 x 80.

III Revestimiento: Avalon Cemento 60 x 60, Morgana Cemento 60 x 60.

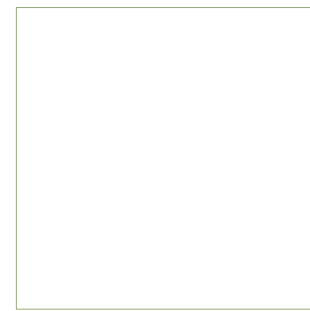

**80x80 Avalon**  
 Marengo **61LN56R** (06-07)  
 Blanco **61LN46R** (06-07)  
 Cemento **61LN16R** (06-07)  
 Antracita **61LN66R** (06-07)  
 Taupé **61LN26R** (06-07)

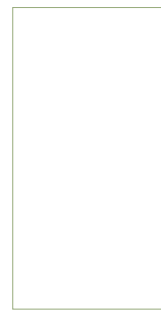

**40x80 Avalon**  
 Marengo **61LN53R** (06-07)  
 Blanco **61LN43R** (06-07)  
 Cemento **61LN13R** (06-07)  
 Antracita **61LN63R** (06-07)  
 Taupé **61LN23R** (06-07)



**60x60 Avalon**  
 Marengo **52LN55R** (07-83)  
 Blanco **52LN45R** (07-83)  
 Cemento **52LN15R** (07-83)  
 Antracita **52LN65R** (07-83)  
 Taupé **52LN25R** (07-83)



**15x15 Avalon**  
 Marengo **06TLN50** (05-12)  
 Blanco **06TLN40** (05-12)  
 Cemento **06TLN10** (05-12)  
 Antracita **06TLN60** (05-12)  
 Taupé **06TLN20** (05-12)

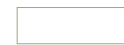

**7x28 Avalon**  
 Marengo **57LN50L** (08-50)  
 Blanco **57LN40L** (08-50)  
 Cemento **57LN10L** (08-50)  
 Antracita **57LN60L** (08-50)  
 Taupé **57LN20L** (08-50)

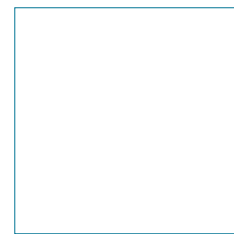

**60,3x60,3 Avalon 20MM**  
 Marengo **52LNE55** (96-50)  
 Cemento **52LNE15** (96-50)  
 Antracita **52LNE65** (96-50)



**Peldaño Escuadra**  
 30x30 (13-97)  
 30x60 (20-60)

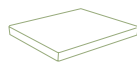

**Peldaño Escuadra Ang.**  
 30x30 (20-60)  
 30x60 (20-70)



**Rodapié**  
 8x60 (12-46)  
 8x80 (13-04)

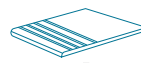

**Peldaño Porcelánico Romo Huella**  
 30x60,3 (13-81)



**60x60 Morgana\***

Marengo **52LN515** (07-89) IV  
 Blanco **52LN415** (07-89) V  
 Cemento **52LN115** (07-89) IV  
 Antracita **52LN615** (07-89) IV  
 Taupé **52LN215** (07-89) IV

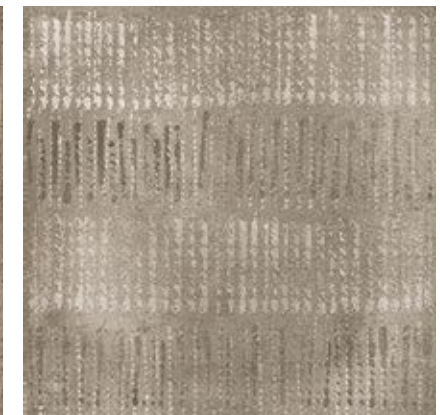

(\*): 3 gráficas diferentes empaquetadas aleatoriamente en cajas de 3 piezas.  
 3 different patterns randomly selected and packed in boxes containing 3 pieces.  
 3 verschiedene Grafiken, aleatorisch verpackt mit 3 Stück pro Karton.  
 3 graphiques différents, empaquetés par cartons de 3 pièces de façon aléatoire.  
 3 pezzi diversi, confezionati casualmente in scatole da 3 pezzi ciascuna.  
 3 verschillende patronen, willekeurig geselecteerd en verpakt in dozen van 3 stuks.  
 3 różnych wzorów powierzchni wybieranych losowo i zapakowane w pudełkach zawierające 3 sztuk.  
 3 различных графических рисунков, упакованных путем случайного выбора по 3 штук в коробке.

medida cm	nºpzax/box	m <sup>2</sup> /box	kg/box	boxes/pallet	m <sup>2</sup> /pallet	kg/pallet
80x80	2	1,28	34,25	40	51,20	1.370,00
40x80	3	0,96	26,75	30	28,80	802,50
60,3x60,3 20MM	2	0,73	33,50	32	23,36	1.072,00
60x60	3	1,08	25,75	32	34,56	824,00
15x15	20	0,45	7,80	100	45,00	780,00
7x28	10	0,20	10,00	100	20,00	1.000,00

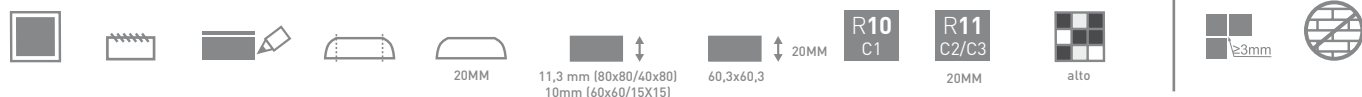



AVENUE 80X80 31<sup>1</sup>/<sub>2</sub>"X31<sup>1</sup>/<sub>2</sub>" 60X60 23<sup>5</sup>/<sub>8</sub>"X23<sup>5</sup>/<sub>8</sub>" 30X60 11<sup>13</sup>/<sub>16</sub>"X23<sup>5</sup>/<sub>8</sub>" 15X15 5<sup>7</sup>/<sub>8</sub>" X5<sup>7</sup>/<sub>8</sub>"



AVENUE 80X80 31<sup>1/2</sup>"X31<sup>1/2</sup>" 60X60 23<sup>5/8</sup>"X23<sup>5/8</sup>" 30X60 11<sup>13/16</sup>"X23<sup>5/8</sup>" 15X15 5<sup>7/8</sup>" X5<sup>7/8</sup>"



BLANCO



NEGRO



MARENGO



GRIS



80x80 Avenue  
Blanco **61AE46P** (06-08)  
Negro **61AE96P** (06-08)  
Marengo **61AE56P** (06-08)  
Gris **61AE36P** (06-08)



60x60 Avenue  
Blanco **52AE45P** (07-94)  
Negro **52AE95P** (07-94)  
Marengo **52AE55P** (07-94)  
Gris **52AE35P** (07-94)

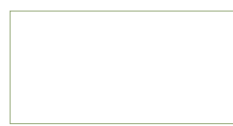

30x60 Avenue  
Blanco **46AE42P** (07-93)  
Negro **46AE92P** (07-93)  
Marengo **46AE52P** (07-93)  
Gris **46AE32P** (07-93)



15x15 Avenue  
Blanco **06TAE4P** (05-44)  
Negro **06TAE9P** (05-44)  
Marengo **06TAE5P** (05-44)  
Gris **06TAE3P** (05-44)



Peldaño Escuadra  
30x30 (13-97)  
30x60 (20-60)



Peldaño Escuadra Ang.  
30x30 (20-60)  
30x60 (20-70)



Rodapié  
8x60 (12-65)  
8x80 (13-04)

≡ Pavimento: Avenue Negro 80 x 80.

medida cm	nºpzax/box	m²/box	kg/box	boxes/pallet	m²/pallet	kg/pallet
80x80	2	1,28	34,25	40	51,20	1.370,00
60x60	3	1,08	25,75	32	34,56	824,00
30x60	6	1,08	24,80	40	43,20	992,00
15x15	20	0,45	7,80	100	45,00	780,00



11,3 mm (80x80)  
10 mm (60x60 / 30x60/15x15)



medio



3mm



**BASILEA** 45X90 17<sup>3</sup>/<sub>4</sub>"X35<sup>7</sup>/<sub>16</sub>" 22X90 8<sup>11</sup>/<sub>16</sub>"X35<sup>7</sup>/<sub>16</sub>"



BLANCO

IV



GRIS

IV



ANTRACITA

IV

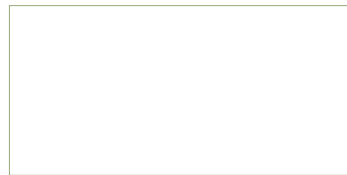

45x90 Basilea  
Blanco **54BA47R** (05-62)  
Gris **54BA37R** (05-62)  
Antracita **54BA57R** (05-62)



22x90 Basilea  
Blanco **56BA47L** (06-05)  
Gris **56BA37L** (06-05)  
Antracita **56BA57L** (06-05)

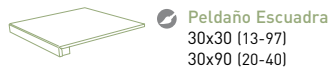

Peldaño Escuadra  
30x30 (13-97)  
30x90 (20-40)

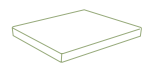

Peldaño Escuadra Ang.  
30x30 (20-60)  
30x90 (20-50)



Rodapié  
8x45 (12-41)



≡ Pavimento: Basilea Gris 45 x 90.

medida cm	nºpzax/box	m <sup>2</sup> /box	kg/box	boxes/pallet	m <sup>2</sup> /pallet	kg/pallet
45x90	3	1,22	30,50	27	32,94	823,50
22x90	5	1,00	25,00	54	54,00	1.350,20



BELLVER 45X90 17<sup>3</sup>/<sub>4</sub>"X35<sup>7</sup>/<sub>16</sub>" 45X45 17<sup>3</sup>/<sub>4</sub>"X17<sup>3</sup>/<sub>4</sub>" 30X60 11<sup>13</sup>/<sub>16</sub>"X23<sup>5</sup>/<sub>8</sub>" 30X30 11<sup>13</sup>/<sub>16</sub>"X11<sup>13</sup>/<sub>16</sub>"



BEIGE IV



30x60 Muralla  
Beige **46MR-72** (07-87)  
Marrón **46MR-22** (07-87)  
Gris **46MR-32** (07-87)



MARRON IV



30x30 Almena  
Beige **41BV70A** (09-05)  
Marrón **41BV20A** (09-05)  
Gris **41BV30A** (09-05)



GRIS IV

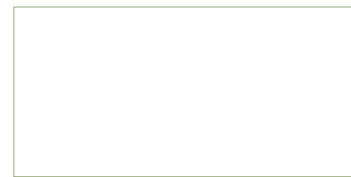

45x90 Bellver  
Beige **54BE77R** (08-09)  
Marrón **54BE27R** (08-09)  
Gris **54BE37R** (08-09)



45x45 Bellver  
Beige **42BV-78** (07-74)  
Marrón **42BV-28** (07-74)  
Gris **42BV-38** (07-74)

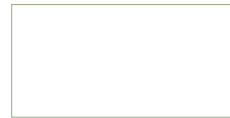

30x60 Bellver  
Beige **46BV-72** (07-81)  
Marrón **46BV-22** (07-81)  
Gris **46BV-32** (07-81)



30x30 Bellver  
Beige **41BV-70** (07-60)  
Marrón **41BV-20** (07-60)  
Gris **41BV-30** (07-60)

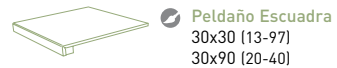

Peldaño Escuadra  
30x30 (13-97)  
30x90 (20-40)

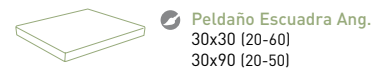

Peldaño Escuadra Ang.  
30x30 (20-60)  
30x90 (20-50)



Rodapié  
8x30 (10-65)  
8x45 (11-81)



30x30 Musa Fossil  
Beige **69MU-FB** (40x40)



30x30 Musa Fossil  
Antracita **69MU-FA** (40-40)



26,4x27,4 Musa Exagono  
Marrón **69MU-EM** (40-70)



26,4x27,4 Musa Exagono  
Negro **69MU-EN** (40-70)



30x30 Musa Rectangular  
Marrón **69MU-RM** (40-40)

≡ Pavimento: Bellver Marrón 45 x 45 / 30 x 60 / 30 x 30.

medida cm	nºpzax/box	m²/box	kg/box	boxes/pallet	m²/pallet	kg/pallet
45x90	3	1,22	30,50	27	32,94	823,50
45x45	5	1,01	23,30	66	66,66	1.537,80
30x60	6	1,08	24,80	40	43,20	992,00
30x30	10	0,90	20,70	48	43,20	993,60
30x30 mallado	11	1,00	20,00	36	36,00	720,00



**BILBAO** 45X90 17<sup>3/4</sup>"X35<sup>7/16</sup>" 60X60 23<sup>5/8</sup>"X23<sup>5/8</sup>" 30X60 11<sup>13/16</sup>"X23<sup>5/8</sup>"



BEIGE V

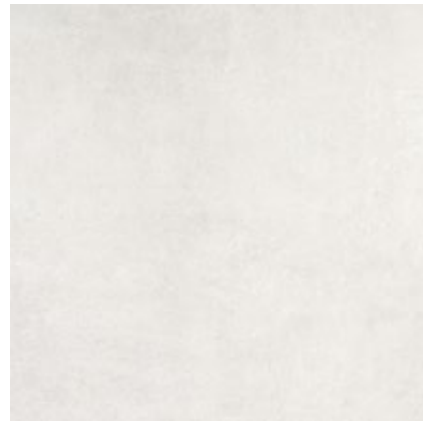

GRIS IV



CEMENTO IV



ANTRACITA IV



≡ Pavimento: Bilbao Cemento 60 x 60.

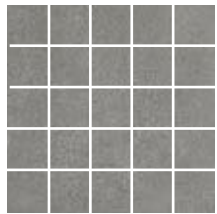

30x30 Nervion  
Beige **41NE-20** (09-05)  
Gris **41NE-30** (09-05)  
Cemento **41NE-10** (09-05)  
Antracita **41NE-50** (09-05)

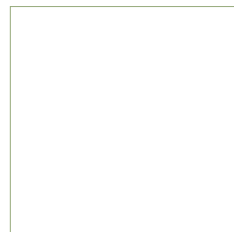

**60x60 Bilbao**  
Beige **52BI25R** (08-05)  
Gris **52BI35R** (08-05)  
Cemento **52BI15R** (08-05)  
Antracita **52BI55R** (08-05)  
**60x60 Bilbao Pulido**  
Beige **52BI25P** (07-94)  
Gris **52BI35P** (07-94)  
Cemento **52BI15P** (07-94)  
Antracita **52BI55P** (07-94)

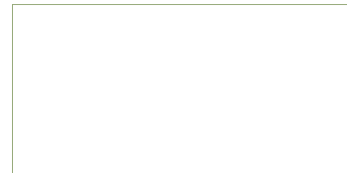

**45x90 Bilbao**  
Beige **54BI27R** (08-09)  
Gris **54BI37R** (08-09)  
Cemento **54BI17R** (08-09)  
Antracita **54BI57R** (08-09)  
**45x90 Bilbao Pulido**  
Beige **54BI27P** (08-11)  
Gris **54BI37P** (08-11)  
Cemento **54BI17P** (08-11)  
Antracita **54BI57P** (08-11)

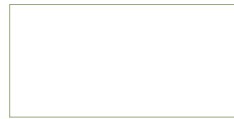

**30x60 Bilbao**  
Beige **46BI-22** (07-81)  
Gris **46BI-32** (07-81)  
Cemento **46BI-12** (07-81)  
Antracita **46BI-52** (07-81)



**9,7x60 Bilbao**  
Beige **57BI21D** (05-74)  
Gris **57BI31D** (05-74)  
Cemento **57BI11D** (05-74)  
Antracita **57BI51D** (05-74)

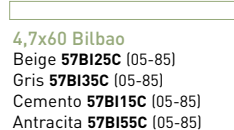

**4,7x60 Bilbao**  
Beige **57BI25C** (05-85)  
Gris **57BI35C** (05-85)  
Cemento **57BI15C** (05-85)  
Antracita **57BI55C** (05-85)



**14,5x60 Bilbao**  
Beige **57BI22L** (05-57)  
Gris **57BI32L** (05-57)  
Cemento **57BI12L** (05-57)  
Antracita **57BI52L** (05-57)

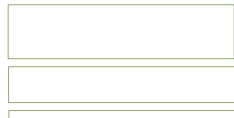

**14,5x60 / 9,7x60 / 4,7x60 Mix Bilbao 60**  
Beige **57BI2MX** (05-84)  
Gris **57BI3MX** (05-84)  
Cemento **57BI1MX** (05-84)  
Antracita **57BI5MX** (05-84)



● Peldaño Escuadra  
30x30 (13-97)  
30x90 (20-40)



● Peldaño Escuadra Ang.  
30x30 (20-60)  
30x90 (20-50)



● Rodapié  
8x45 (11-81)  
8x60 (12-46)

≡ Pavimento: Bilbao Cemento 60 x 60.

medida cm	nºpzax/box	m²/box	kg/box	boxes/pallet	m²/pallet	kg/pallet
45x90	3	1,22	30,50	27	32,94	823,50
60x60	3	1,08	25,75	32	34,56	824,00
30x60	6	1,08	24,80	40	43,20	992,00
30x30 mallado	11	1,00	20,00	36	36,00	720,00

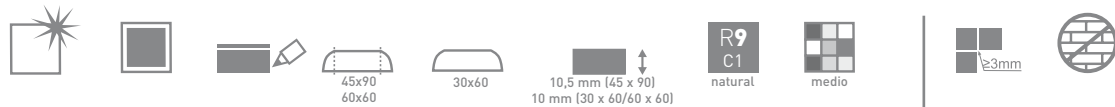

BOSTON 80X80 31 1/2" X 31 1/2" 60X60 23 5/8" X 23 5/8" 40X80 15 6/4" X 31 1/2" 45X45 17 3/4" X 17 3/4"



≡ Pavimento: Boston Antracita 40 x 80.

**BOSTON** 80X80 31<sup>1/2</sup>"X31<sup>1/2</sup>" 60X60 23<sup>5/8</sup>"X23<sup>5/8</sup>" 40X80 15<sup>6/4</sup>"X31<sup>1/2</sup>" 45X45 17<sup>3/4</sup>"X17<sup>3/4</sup>"

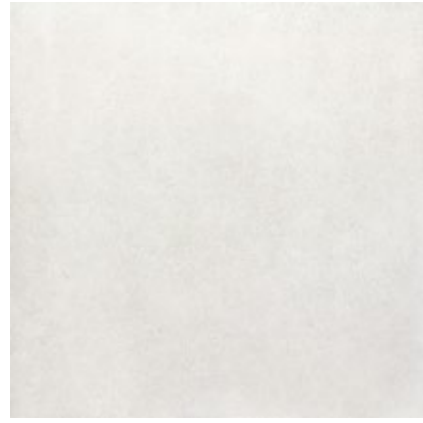

GRIS IV



CEMENTO IV

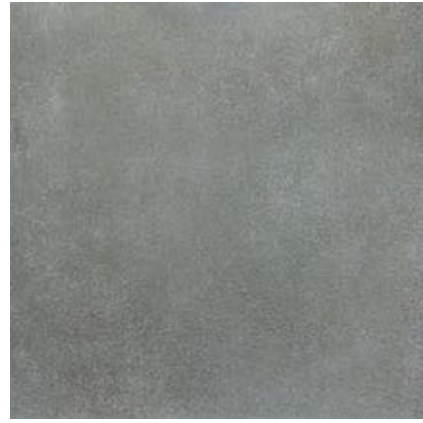

ANTRACITA IV



BEIGE IV

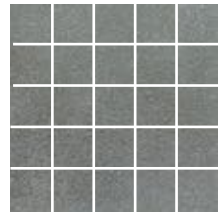

30x30 Mystic  
Gris 41MY-30 [09-05]  
Cemento 41MY-10 [09-05]  
Antracita 41MY-60 [09-05]  
Beige 41MY-70 [09-05]

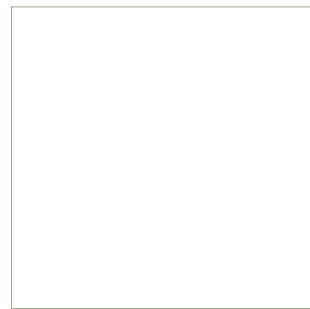

80x80 Boston  
Gris 61B0-36 [06-06]  
Cemento 61B0-16 [06-06]  
Antracita 61B0-66 [06-06]  
Beige 61B0-76 [06-06]

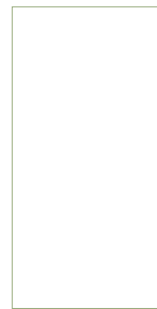

40x80 Boston  
Gris 61B033R [06-06]  
Cemento 61B013R [06-06]  
Antracita 61B063R [06-06]  
Beige 61B073R [06-06]



60x60 Boston  
Gris 52B035R [07-83]  
Cemento 52B015R [07-83]  
Antracita 52B065R [07-83]  
Beige 52B075R [07-83]



45x45 Boston  
Gris 42B0-38 [07-60]  
Cemento 42B0-18 [07-60]  
Antracita 42B0-68 [07-60]  
Beige 42B0-78 [07-60]  
Blanco 42B0-48 [07-60]



Peldaño Escuadra  
30x30 [13-97]  
30x60 [20-60]

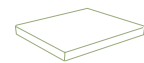

Peldaño Escuadra Ang.  
30x30 [20-60]  
30x60 [20-70]



Rodapié  
8x60 [12-46]  
8x80 [13-04]

≡ Pavimento: Boston Gris 60 x 60.

medida cm	nºpzas/box	m²/box	kg/box	boxes/pallet	m²/pallet	kg/pallet
80x80	2	1,28	34,25	40	51,20	1.370,00
40x80	3	0,96	26,75	30	28,80	802,50
60x60	3	1,08	25,75	32	34,56	824,00
45x45	5	1,01	23,30	66	66,66	1.537,80



**CALACATA** 60X120 23<sup>5/8</sup>"X47<sup>11/16</sup>" 60X60 23<sup>5/8</sup>"X23<sup>5/8</sup>" 30X60 11<sup>13/16</sup>"X23<sup>5/8</sup>"  
10X30 3<sup>15/16</sup>"X11<sup>13/16</sup>"





**CALACATA** 60X120 23<sup>5/8</sup>"X47<sup>11/16</sup>" 60X60 23<sup>5/8</sup>"X23<sup>5/8</sup>" 30X60 11<sup>13/16</sup>"X23<sup>5/8</sup>"  
 30X30 11<sup>13/16</sup>"X11<sup>13/16</sup>" 10X30 3<sup>15/16</sup>"X11<sup>13/16</sup>"



CALACATA IV



CALACATA ABUJARDADO IV



30x60 Ferrara  
46FE42R (08-05)



30x60 Modena  
46MO42R (08-05)



30x30 Lucca  
41LC40L (09-05)



25x25 Forli  
08FO-40 (13-72)



2,5x30 Torello Calacata  
08TOCAL (11-40)

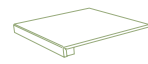

● Peldaño Escuadra  
30x30 (13-97)  
30x120 (20-80)

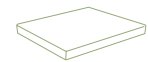

● Peldaño Escuadra Ang.  
30x30 (20-60)  
30x120 (20-90)



● Rodapié  
8x60 (12-46)



≡ Pavimento: Pirineos Antracita 60 x 120. III Revestimiento: Calacata 30 x 60, Modena 30 x 60, Forli 25 x 25.  
 □ Mueble: Coverlam Basic Gris.

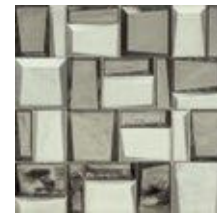

30 x 30 Musa Cristal Plata  
69MU-CP (40-75)



30 x 30 Musa Cristal Oro  
69MU-CR (40-75)



30 x 30 Musa Marquina  
69MU-MA (40-40)

**CALACATA 25 25X40** 9<sup>7/8</sup>"X15<sup>6/8</sup>"

REVESTIMIENTO  
WALL TILE

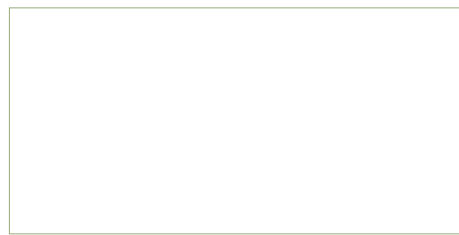

60x120 Calacata  
58LC49R (08-12)

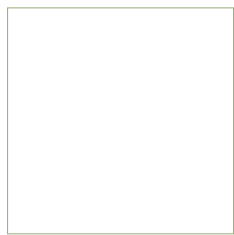

60x60 Calacata  
52LC45R (08-05)

60x60 Calacata Abujardado  
52LC415 (08-05)



10x30 Calacata  
57LC40L (08-65)

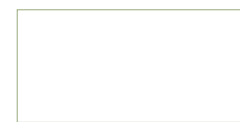

30x60 Calacata  
46LC42R (05-05)

30x60 Calacata Abujardado  
46LC412 (05-05)

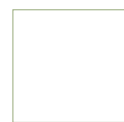

30x30 Calacata  
40LC40 (1-35)



25x40 Calacata 25  
15LC405 (01-30)



25x40 Parma 25  
15LC415 (01-40)



25x40 Pisa 25  
15LC425 (01-40)

medida cm	nºpzax/box	m²/box	kg/box	boxes/pallet	m²/pallet	kg/pallet
60x120	2	1,44	38,50	25	36,00	962,50
60x60	3	1,08	25,75	32	34,56	824,00
30x60	6	1,08	24,80	40	43,20	992,00
30x30	10	0,90	19,90	48	43,20	955,20
10x30	10	0,30	6,16	100	30,00	616,00
25x40 revestimiento	12	1,20	17,50	54	64,80	945,00



CAMBRIDGE 29,5X120 11<sup>39/64</sup>"X47<sup>11/16</sup>" 19,5X120 7<sup>10/16</sup>"X47<sup>11/16</sup>" 14,5X120 5<sup>23/32</sup>"X47<sup>11/16</sup>"  
15X80 5<sup>7/8</sup>"X31<sup>1/2</sup>"



**CAMBRIDGE** 29,5X120 11<sup>39/64</sup>"X47<sup>11/16</sup>" 19,5X120 7<sup>10/16</sup>"X47<sup>11/16</sup>" 14,5X120 5<sup>23/32</sup>"X47<sup>11/16</sup>"  
15X80 5<sup>7/8</sup>"X31<sup>1/2</sup>"



CARAMEL

IV



COFFEE

IV



MIDNIGHT

IV



MOON

IV



29,5x120 Cambridge  
Caramel **59MB79M** (05-88)  
Coffee **59MB29M** (05-88)  
Midnight **59MB59M** (05-88)  
Moon **59MB49M** (05-88)



19,5x120 Cambridge  
Caramel **59MB79T** (05-88)  
Coffee **59MB29T** (05-88)  
Midnight **59MB59T** (05-88)  
Moon **59MB49T** (05-88)



14,5x120 Cambridge  
Caramel **59MB79L** (05-88)  
Coffee **59MB29L** (05-88)  
Midnight **59MB59L** (05-88)  
Moon **59MB49L** (05-88)



15x80 Cambridge  
Caramel **50MB-71** (00-87)  
Coffee **50MB-21** (00-87)  
Midnight **50MB-51** (00-87)  
Moon **50MB-41** (00-87)

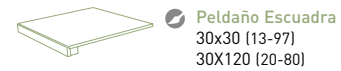

● Peldaño Escuadra  
30x30 (13-97)  
30X120 (20-80)

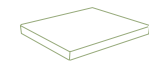

● Peldaño Escuadra Ang.  
30x30 (20-60)  
30X120 (20-90)



● Rodapié  
8x60 (12-65)



alto



≡ Pavimento: Cambridge Caramel 19,5 x 120.

medida cm	nºpzax/box	m²/box	kg/box	boxes/pallet	m²/pallet	kg/pallet
29,5x120	3	1,06	29,15	36	38,16	1.049,40
19,5x120	5	1,17	31,50	36	42,12	1.134,00
14,5x120	7	1,22	33,50	32	39,04	1.072,00
15x80	9	1,08	26,00	48	51,84	1.248,00

**CAMBRIDGE** 29,5X120 11<sup>39/64</sup>"X47<sup>11/16</sup>" 19,5X120 7<sup>10/16</sup>"X47<sup>11/16</sup>" 14,5X120 5<sup>23/32</sup>"X47<sup>11/16</sup>"  
 15X80 5<sup>7/8</sup>"X31<sup>1/2</sup>"



CAMBRIDGE CARAMEL 19,5X120



CAMBRIDGE MIDNIGHT 19,5X120



CAMBRIDGE COFFEE 19,5X120



CAMBRIDGE MOON 19,5X120

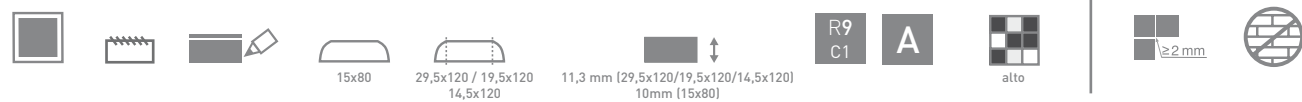

medida cm	nºpzax/box	m²/box	kg/box	boxes/pallet	m²/pallet	kg/pallet
29,5x120	3	1,06	29,15	36	38,16	1.049,40
19,5x120	5	1,17	31,50	36	42,12	1.134,00
14,5x120	7	1,22	33,50	32	39,04	1.072,00
15x80	9	1,08	26,00	48	51,84	1.248,00

# CANAIMA 15X60 5<sup>7</sup>/<sub>8</sub>" X 23<sup>5</sup>/<sub>8</sub>"



ABETO IV



SECUOYA IV



CEDRO IV



ENCINA IV



CIPRÉS IV



OLIVO IV



BAMBÚ IV



OLMO IV



WENGUÉ IV



- |                                |   |
|--------------------------------|---|
| <b>15x60 Canaima</b>           | <b>15x60 Canaima Antislip</b>  |
| Abeto <b>57CA-34</b> (04-10)   | Abeto <b>57CAA34</b> (04-15)  |
| Secuoya <b>57CA-74</b> (04-10) | Secuoya <b>57CAA74</b> (04-15)  |
| Cedro <b>57CA-04</b> (04-10)   | Cedro <b>57CAA04</b> (04-15)  |
| Encina <b>57CA-14</b> (04-10)  | Encina <b>57CAA14</b> (04-15)   |
| Ciprés <b>57CA-54</b> (04-10)  | Ciprés <b>57CAA54</b> (04-15)   |
| Olivo <b>57CA-94</b> (04-10)   | Olivo <b>57CAA94</b> (04-15)  |
| Bambú <b>57CA-24</b> (04-10)   | Bambú <b>57CAA24</b> (04-15)  |
| Olmo <b>57CA-84</b> (04-10)    | Olmo <b>57CAA84</b> (04-15)   |
| Wengué <b>57CA-64</b> (04-10)  | Wengué <b>57CAA64</b> (04-15)   |



Rodapié  
8 x 30 (10-65)



≡ Pavimento: Canaima Secuoya 15 x 60.

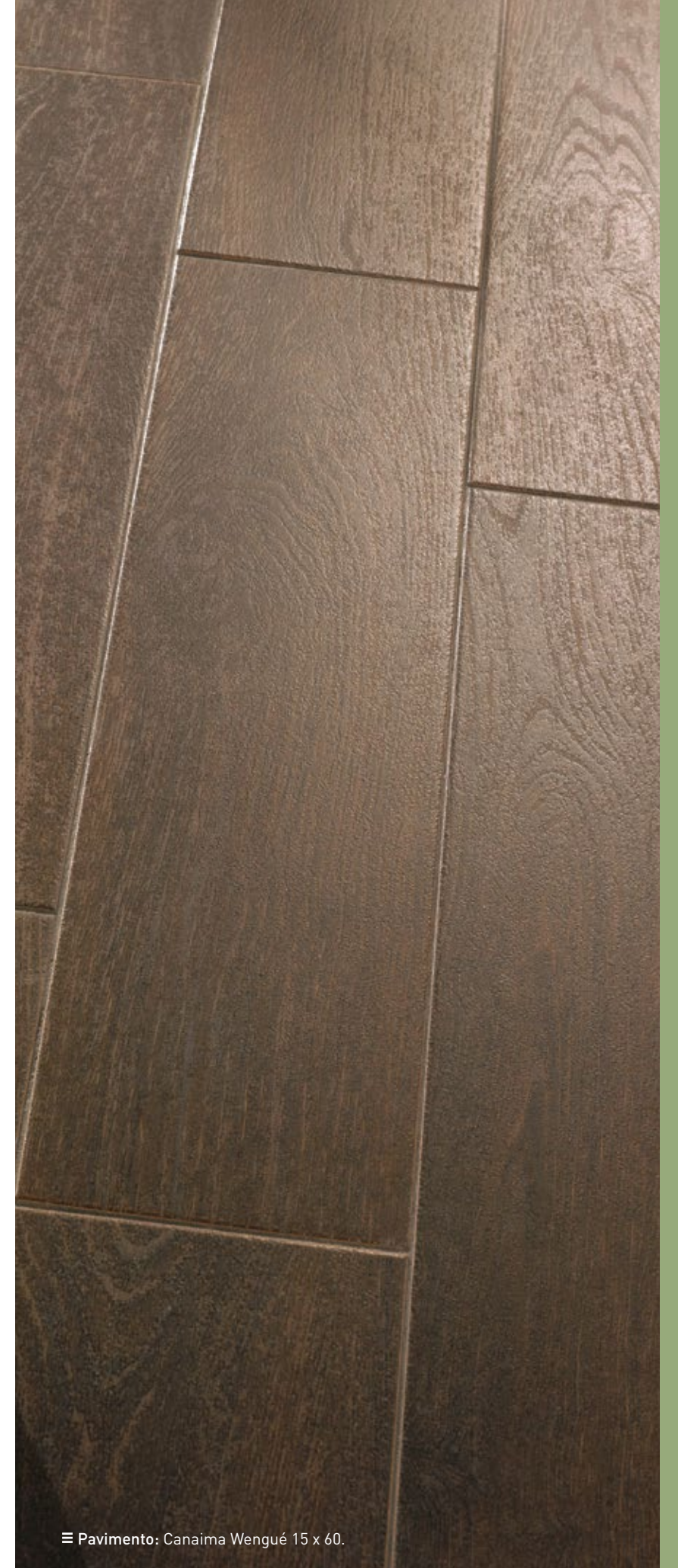

≡ Pavimento: Canaima Wengué 15 x 60.



medida cm	nºpzax/box	m <sup>2</sup> /box	kg/box	boxes/pallet	m <sup>2</sup> /pallet	kg/pallet
15x60	12	1,08	26,00	40	43,20	1.040,00

CAVA 29,5X120 11<sup>39/64</sup>"X47<sup>11/16</sup>" 19,5X120 7<sup>10/16</sup>"X47<sup>11/16</sup>" 14,5X120 5<sup>23/32</sup>"X47<sup>11/16</sup>"  
15X80 5<sup>7/8</sup>"X31<sup>1/2</sup>"



III Revestimiento: Cava Verdejo 15 x 80, Lar 15 x 80

III Pavimento: Cava Verdejo 15 x 80

**CAVA** 29,5X120 11<sup>39/64</sup>"X47<sup>11/16</sup>" 19,5X120 7<sup>10/16</sup>"X47<sup>11/16</sup>" 14,5X120 5<sup>23/32</sup>"X47<sup>11/16</sup>"  
15X80 5<sup>7/8</sup>"X31<sup>1/2</sup>"



RIBEIRO

IV



FINO

IV



VERDEJO

IV



BOBAL

IV



COGNAC

IV

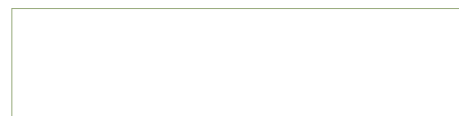

29,5x120 Cava  
Ribeiro **59CV49M** (05-80)  
Fino **59CV39M** (05-80)  
Verdejo **59CV29M** (05-80)  
Bobal **59CV19M** (05-80)  
Cognac **59CV89M** (05-80)

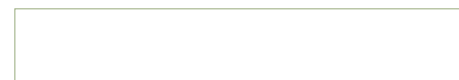

19,5x120 Cava  
Ribeiro **59CV49T** (05-80)  
Fino **59CV39T** (05-80)  
Verdejo **59CV29T** (05-80)  
Bobal **59CV19T** (05-80)  
Cognac **59CV89T** (05-80)



14,5x120 Cava  
Ribeiro **59CV49L** (05-80)  
Fino **59CV39L** (05-80)  
Verdejo **59CV29L** (05-80)  
Bobal **59CV19L** (05-80)  
Cognac **59CV89L** (05-80)



15x80 Cava  
Ribeiro **50CV-41** (00-90)  
Fino **50CV-31** (00-90)  
Verdejo **50CV-21** (00-90)  
Bobal **50CV-11** (00-90)  
Cognac **50CV-81** (00-90)

15x80 Cava Antislip   
Ribeiro **50CVA41** (00-95)  
Fino **50CVA31** (00-95)  
Verdejo **50CVA21** (00-95)  
Bobal **50CVA11** (00-95)  
Cognac **50CVA81** (00-95)

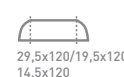
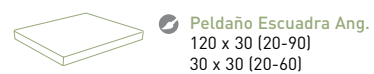

≡ Pavimento: Cava Bobal 15 x 80

medida cm	nºpzax/box	m²/box	kg/box	boxes/pallet	m²/pallet	kg/pallet
29,5x120	3	1,06	29,15	36	38,16	1.049,40
19,5x120	5	1,17	31,50	36	42,12	1.134,00
14,5x120	7	1,22	33,50	32	39,04	1.072,00
15x80	9	1,08	26,00	48	51,84	1.248,00

**CAVA** 29,5X120 11<sup>39/64</sup>"X47<sup>11/16</sup>" 19,5X120 7<sup>10/16</sup>"X47<sup>11/16</sup>" 14,5X120 5<sup>23/32</sup>"X47<sup>11/16</sup>"  
 15X80 5<sup>7/8</sup>"X31<sup>1/2</sup>"



15x80 Lar\*  
50CV-2LA (00-97)

IV

(\*) Distintas gráficas empaquetadas aleatoriamente en cajas de 9 piezas.  
 Different designs randomly packed in boxes of 9.  
 Verschiedene Grafiken aleatorisch verpackt mit 9 Stück pro Karton.  
 Graphiques distincts empaquetés de façon aléatoire par carton de 9 pièces.  
 Grafiche diverse imballate casualmente in scatole da 9 pezzi.  
 Verschillende designs willekeurig verpakt in dozen van 9 stuks.  
 Różne wzory pakowane losowo, po 9 sztuk w paczce.  
 Упаковано в коробках по 9 изделий с различными рисунками, выбранных случайным образом.



45x45 Antica  
42CV-58 (07-75)

IV



RIBEIRO 15X80

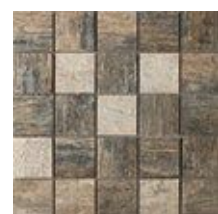

30x30 Reserva  
 Bobal 41CV10R (09-05)  
 Ribeiro 41CV40R (09-05)  
 Verdejo 41CV20R (09-05)  
 Fino 41CV30R (09-05)  
 Cognac 41CV80R (09-05)



FINO 15X80



VERDEJO 15X80



BOBAL 15X80



COGNAC 15X80

medida cm	nºpzax/box	m²/box	kg/box	boxes/pallet	m²/pallet	kg/pallet
29,5x120	3	1,06	29,15	36	38,16	1.049,40
19,5x120	5	1,17	31,50	36	42,12	1.134,00
14,5x120	7	1,22	33,50	32	39,04	1.072,00
15x80	9	1,08	26,00	48	51,84	1.248,00



15x80/Antica/Lar



29,5x120/19,5x120  
14,5x120



11,3 mm (29,5x120/  
19,5x120/14,5x120)  
10 mm (15x80)



R13

antislip



R10

C1



alto



2mm





**CUBANA** 19,5X120 7<sup>10/16</sup>"X47<sup>11/16</sup>" 14,5X120 5<sup>23/32</sup>"X47<sup>11/16</sup>"



ABETO IV



BAMBÚ IV



CIPRÉS IV



CEDRO IV



ENCINA IV



OLIVO IV



OLMO IV



SECUOYA IV



WENGUÉ IV



≡ Pavimento: Cubana Abeto 19,5 x 120.  
 ≡≡≡ Revestimiento: Cubana Secuoya 14,5 x 120.

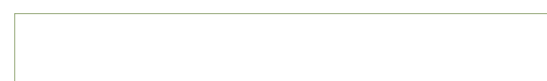

- 19,5x120 Cubana**  
 Abeto **59CU39T** (05-80)  
 Bambú **59CU29T** (05-80)  
 Ciprés **59CU59T** (05-80)  
 Cedro **59CU09T** (05-80)  
 Encina **59CU19T** (05-80)  
 Olivo **59CU99T** (05-80)  
 Olmo **59CU89T** (05-80)  
 Secuoya **59CU79T** (05-80)  
 Wengué **59CU69T** (05-80)



- 14,5x120 Cubana**  
 Abeto **59CU39L** (05-80)  
 Bambú **59CU29L** (05-80)  
 Ciprés **59CU59L** (05-80)  
 Cedro **59CU09L** (05-80)  
 Encina **59CU19L** (05-80)  
 Olivo **59CU99L** (05-80)  
 Olmo **59CU89L** (05-80)  
 Secuoya **59CU79L** (05-80)  
 Wengué **59CU69L** (05-80)

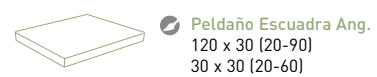
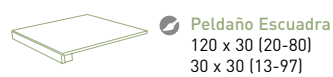

≡ Pavimento: Cubana Wengué 19,5 x 120, 14,5 x 120.

medida cm	nºpzax/box	m²/box	kg/box	boxes/pallet	m²/pallet	kg/pallet
19,5x120	5	1,17	31,50	36	42,12	1.134,00
14,5x120	7	1,22	33,50	32	39,04	1.072,00



**DOCK** 60x60 23<sup>5/8</sup>"x23<sup>5/8</sup>" 45x45 17<sup>3/4</sup>"x17<sup>3/4</sup>" 30x60 11<sup>13/16</sup>"x23<sup>5/8</sup>"  
 60,3x60,3 23<sup>3/4</sup>"x23<sup>3/4</sup>" **20MM** 75x75 29<sup>17/32</sup>"x29<sup>17/32</sup>" **20MM**



BEIGE V



GRIS IV



ANTRACITA IV



TAUPE IV



NEGRO IV

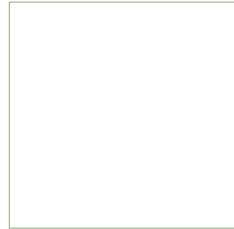

**60x60 Dock**  
 Beige **52D075R** (07-83)  
 Gris **52D035R** (07-83)  
 Antracita **52D065R** (07-83)  
 Taupe **52D025R** (07-83)  
 Negro **52D095R** (07-83)

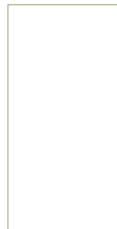

**30x60 Dock**  
 Beige **46D0-72** (07-81)  
 Gris **46D0-32** (07-81)  
 Antracita **46D0-62** (07-81)  
 Taupe **46D0-22** (07-81)  
 Negro **46D0-92** (07-81)



**45x45 Dock**  
 Beige **42D0-78** (07-60)  
 Gris **42D0-38** (07-60)  
 Antracita **42D0-68** (07-60)  
 Taupe **42D0-28** (07-60)  
 Negro **42D0-98** (07-60)

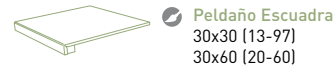

**Peldaño Escuadra**  
 30x30 (13-97)  
 30x60 (20-60)



**Peldaño Escuadra Ang.**  
 30x30 (20-60)  
 30x60 (20-70)



**Rodapié**  
 8x60 (12-46)

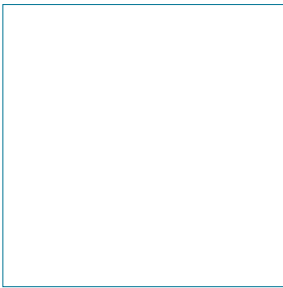

**75x75 Dock 20MM Relieve** **20MM**  
 Beige **61D0E76** (96-65)  
 Gris **61D0E36** (96-65)  
 Antracita **61D0E66** (96-65)



**60,3x60,3 Dock 20MM Relieve** **20MM**  
 Beige **52DOR75** (96-50)  
 Gris **52DOR35** (96-50)  
 Antracita **52DOR65** (96-50)  
 Taupe **52DOR25** (96-50)  
 Negro **52DOR95** (96-50)

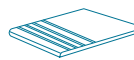

**Peldaño Porcelánico Romo Huella**  
 30x75 (18-00)  
 30x60,3 (13-81)



≡ Pavimento: Dock Taupe 60x60, Dock 20mm Taupe 60,3 x 60,3.

medida cm	nºzas/box	m²/box	kg/box	boxes/pallet	m²/pallet	kg/pallet
75x75 20MM	1	0,56	24,91	42	23,63	1.046,22
60,3x60,3 20MM	2	0,73	33,50	32	23,36	1.072,00
60x60	3	1,08	25,75	32	34,56	824,00
30x60	6	1,08	25,80	40	43,20	1.032,00
45x45	5	1,01	23,30	66	66,66	1.537,80

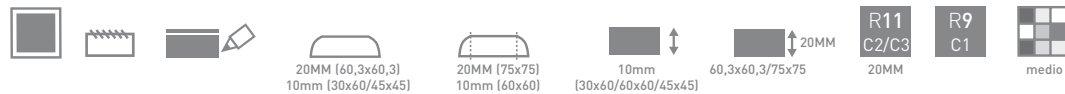

ESCORIAL 80X80 31<sup>1</sup>/<sub>2</sub>" X 31<sup>1</sup>/<sub>2</sub>" / 60X60 23<sup>5</sup>/<sub>8</sub>" X 23<sup>5</sup>/<sub>8</sub>"

NUEVO NEW



PORCELÁNICO PORCELAIN TILES

ESCORIAL 80X80 31<sup>1</sup>/<sub>2</sub>" X 31<sup>1</sup>/<sub>2</sub>" / 60X60 23<sup>5</sup>/<sub>8</sub>" X 23<sup>5</sup>/<sub>8</sub>"

NUEVO NEW



BLANCO IV



BEIGE IV



GRIS IV



NEGRO IV

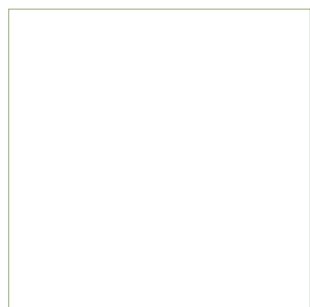
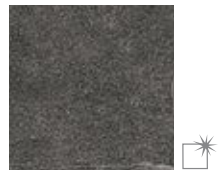
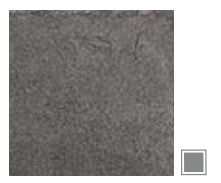

**80x80 Escorial Natural**  
 Blanco **61E046R** (06-07)  
 Beige **61E076R** (06-07)  
 Gris **61E036R** (06-07)  
 Negro **61E096R** (06-07)

**80x80 Escorial Pulido**  
 Blanco **61E046P** (06-08)  
 Beige **61E076P** (06-08)  
 Gris **61E036P** (06-08)  
 Negro **61E096P** (06-08)

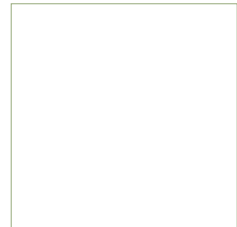

**60x60 Escorial Natural**  
 Blanco **52E045R** (07-83)  
 Beige **52E075R** (07-83)  
 Gris **52E035R** (07-83)  
 Negro **52E095R** (07-83)

**60x60 Escorial Pulido**  
 Blanco **52E045P** (07-94)  
 Beige **52E075P** (07-94)  
 Gris **52E035P** (07-94)  
 Negro **52E095P** (07-94)



**Peldaño Escuadra**  
 30x30 (13-97)  
 30x80 (20-40)

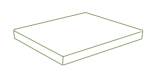

**Peldaño Escuadra Ang.**  
 30x30 (20-60)  
 30x80 (20-50)



**Rodapié**  
 8x60 (12-46)  
 8x80 (13-04)



≡ Pavimento: Escorial Natural Negro 80x80.

medida cm	nºpzax/box	m²/box	kg/box	boxes/pallet	m²/pallet	kg/pallet
80x80	2	1,28	34,25	40	51,20	1.370,00
60x60	3	1,08	25,75	32	34,56	824,00

GEA 60X120 23<sup>5/8</sup>"X47<sup>11/16</sup>" 80X80 31<sup>1/2</sup>"X31<sup>1/2</sup>" 60X60 23<sup>5/8</sup>"X23<sup>5/8</sup>"  
75X75 29<sup>17/32</sup>"X23<sup>17/32</sup>" **ZOMM** 60X60 23<sup>5/8</sup>"X23<sup>5/8</sup>" **ZOMM**



**GEA** 60X120 23<sup>5/8</sup>"X47<sup>11/16</sup>" 80X80 31<sup>1/2</sup>"X31<sup>1/2</sup>" 60X60 23<sup>5/8</sup>"X23<sup>5/8</sup>"  
 75X75 29<sup>17/32</sup>"X29<sup>17/32</sup>" **20MM** 60X60 23<sup>5/8</sup>"X23<sup>5/8</sup>" **20MM**

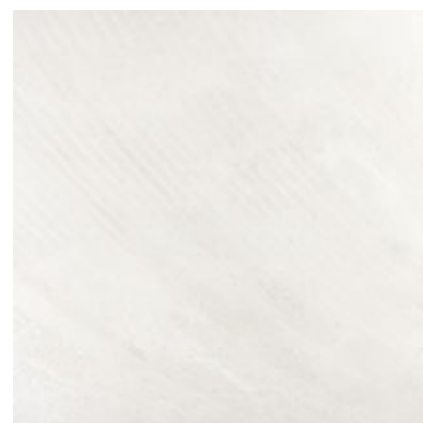

BLANCO

IV

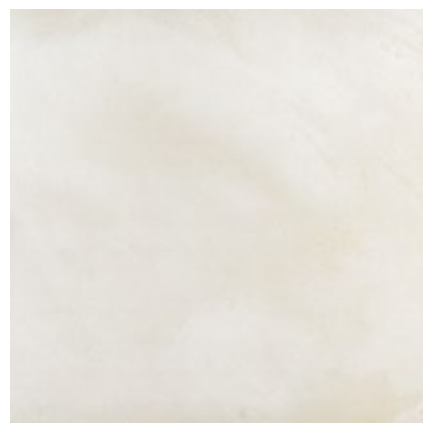

PERLA

IV



CEMENTO

IV

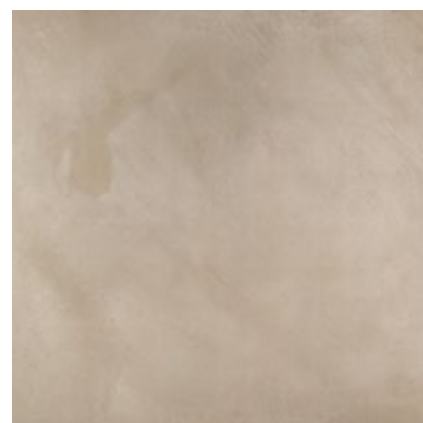

TAUPÉ

IV



ANTRACITA

IV



**80x80 Gea**  
 Blanco **61EG-46** (06-07)  
 Perla **61EG-76** (06-07)  
 Cemento **61EG-16** (06-07)  
 Taupé **61EG-26** (06-07)  
 Antracita **61EG-66** (06-07)

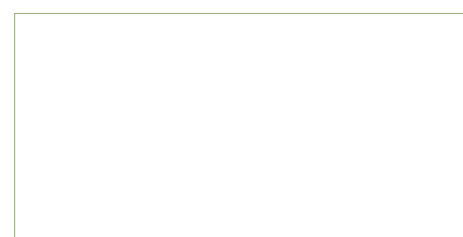

**60x120 Gea**  
 Blanco **58EG49R** (08-08)  
 Perla **58EG79R** (08-08)  
 Cemento **58EG19R** (08-08)  
 Taupé **58EG29R** (08-08)  
 Antracita **58EG69R** (08-08)

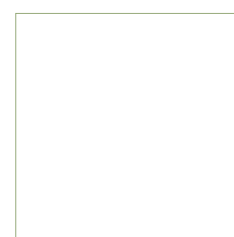

**60x60 Gea**  
 Blanco **52EG45R** (08-05)  
 Perla **52EG75R** (08-05)  
 Cemento **52EG15R** (08-05)  
 Taupé **52EG25R** (08-05)  
 Antracita **52EG65R** (08-05)



**Peldaño Escudra**  
 30x30 (13-97)  
 30x120 (20-80)

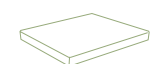

**Peldaño Escudra Ang.**  
 30x30 (20-60)  
 30x120 (20-90)

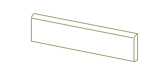

**Rodapié**  
 8x60 (12-46)  
 8x80 (13-04)

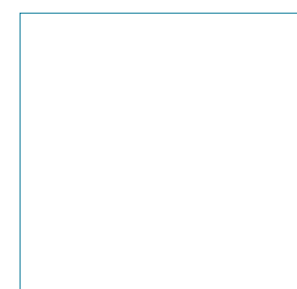

**75x75 Gea 20MM** **20MM**  
 Cemento **61EGE16** (96-65)  
 Antracita **61EGE66** (96-65)

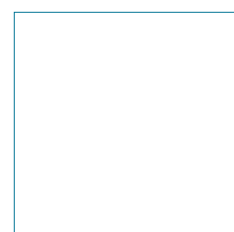

**60x60 Gea 20MM** **20MM**  
 Cemento **52EGE15** (96-60)  
 Antracita **52EGE65** (96-60)



**Peldaño Porcelánico Romo Huella**  
 30x75 (18-00)  
 30x60 (13-81)

≡ Pavimento: Gea Taupé 80 x 80.

medida cm	nºpz/box	m²/box	kg/box	boxes/pallet	m²/pallet	kg/pallet
60x120	2	1,44	38,50	25	36,00	962,50
80x80	2	1,28	34,25	40	51,20	1.370,00
75x75 <b>20MM</b>	1	0,56	24,91	42	23,63	1.046,22
60x60 <b>20MM</b>	2	0,73	33,50	32	23,36	1.072,00
60x60	3	1,08	25,75	32	34,56	824,00

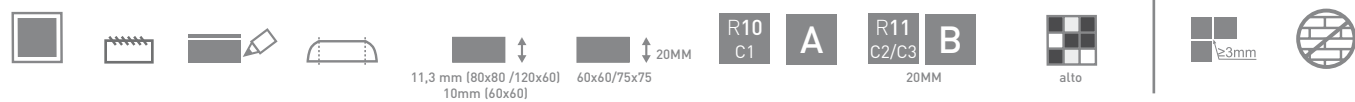

HABANA 60X120 23<sup>5/8</sup>"X47<sup>11/16</sup>" 80X80 31<sup>1/2</sup>"X31<sup>1/2</sup>" 60X60 23<sup>5/8</sup>"X23<sup>5/8</sup>"

NUEVO NEW

<144<188

>188>232

<232<280

PORCELÁNICO PORCELAIN TILES



BLANCO IV



CEMENTO IV



NEGRO IV



COPPER IV



28x28 Stripe  
Copper **08HB-20** (13-30)  
Blanco **08HB-40** (13-30)  
Cemento **08HB-10** (13-30)  
Negro **08HB-90** (13-30)

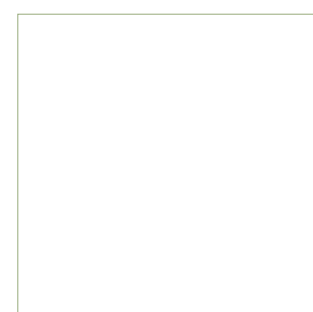

80x80 Habana  
Blanco **61HB-46** (06-07)  
Cemento **61HB-16** (06-07)  
Copper **61HB-26** (06-07)  
Negro **61HB-96** (06-07)

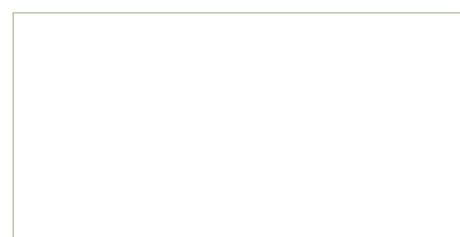

60x120 Habana  
Blanco **58HB49R** (08-07)  
Cemento **58HB19R** (08-07)  
Copper **58HB29R** (08-07)  
Negro **58HB99R** (08-07)

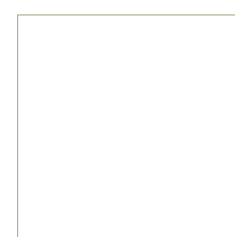

60x60 Habana  
Blanco **52HB45R** (07-82)  
Cemento **52HB15R** (07-82)  
Copper **52HB25R** (07-82)  
Negro **52HB95R** (07-82)

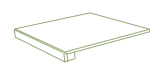

Peldaño Escudra  
30x30 (13-97)  
30x120 (20-80)

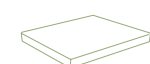

Peldaño Escudra Ang.  
30x30 (20-60)  
30x120 (20-90)



Rodapié  
8x60 (12-46)  
8x80 (13-04)

≡ Pavimento: Habana Copper 60 x 120.

medida cm	nºpzax/box	m²/box	kg/box	boxes/pallet	m²/pallet	kg/pallet
60x120	2	1,44	38,50	25	36,00	962,50
80x80	2	1,28	34,25	40	51,20	1.370,00
60x60	3	1,08	25,75	32	34,56	824,00





HOMESTONE 45X90 17<sup>3</sup>/<sub>4</sub>"X35<sup>7</sup>/<sub>16</sub>" 60X60 23<sup>5</sup>/<sub>8</sub>"X23<sup>5</sup>/<sub>8</sub>" 45X45 17<sup>3</sup>/<sub>4</sub>"X17<sup>3</sup>/<sub>4</sub>" 30X60 11<sup>13</sup>/<sub>16</sub>"X23<sup>5</sup>/<sub>8</sub>"



BLANCO IV



BEIGE IV



GRIS IV



NEGRO IV



TABACO IV

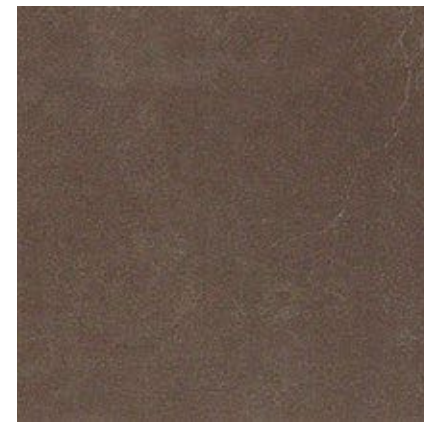

MARENGO IV

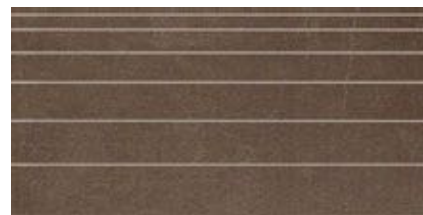

30x60 Aspen  
Blanco 46AS-42 (09-00)  
Beige 46AS-72 (09-00)  
Negro 46AS-92 (09-00)  
Gris 46AS-32 (09-00)  
Tabaco 46AS-22 (09-00)  
Marengo 46AS-52 (09-00)

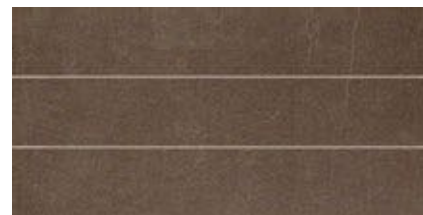

30x60 Paonia  
Blanco 46PA-42 (09-00)  
Beige 46PA-72 (09-00)  
Gris 46PA-32 (09-00)  
Negro 46PA-92 (09-00)  
Tabaco 46PA-22 (09-00)  
Marengo 46PA-52 (09-00)



30x30 Arvada  
Blanco 41AV-40 (09-05)  
Beige 41AV-70 (09-05)  
Gris 41AV-30 (09-05)  
Negro 41AV-90 (09-05)  
Tabaco 41AV-20 (09-05)  
Marengo 41AV-50 (09-05)



30x30 Boulder  
Blanco 41BU-40 (13-77)  
Beige 41BU-70 (13-77)  
Gris 41BU-30 (13-77)  
Negro 41BU-90 (13-77)  
Tabaco 41BU-20 (13-77)  
Marengo 41BU-50 (13-77)



60x60 Homestone  
Blanco 52HO45R (07-82)  
Beige 52HO75R (07-82)  
Gris 52HO35R (07-82)  
Negro 52HO95R (07-82)  
Tabaco 52HO25R (07-82)  
Marengo 52HO55R (07-82)

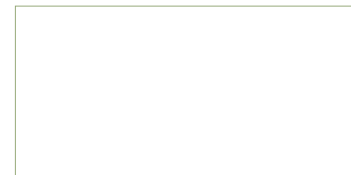

45x90 Homestone  
Blanco 54HO47R (07-92)  
Beige 54HO77R (07-92)  
Gris 54HO37R (07-92)  
Negro 54HO97R (07-92)  
Tabaco 54HO27R (07-92)  
Marengo 54HO57R (07-92)



45x45 Homestone  
Blanco 42HO-48 (07-60)  
Beige 42HO-78 (07-60)  
Gris 42HO-38 (07-60)  
Negro 42HO-98 (07-60)  
Tabaco 42HO-28 (07-60)  
Marengo 42HO-58 (07-60)

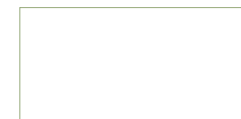

30x60 Homestone  
Blanco 46HO42R (07-82)  
Beige 46HO72R (07-82)  
Gris 46HO32R (07-82)  
Negro 46HO92R (07-82)  
Tabaco 46HO22R (07-82)  
Marengo 46HO52R (07-82)

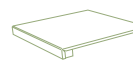

Peldaño Escuadra  
30x30 (13-97)  
30x90 (20-40)

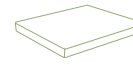

Peldaño Escuadra Ang.  
30x30 (20-60)  
30x90 (20-50)



Rodapié  
8x45 (11-08)  
8x60 (12-46)



≡ Pavimento: Homestone Beige 60 x 60.



≡ Revestimiento: Homestone Tabaco 30 x 60, Paonia Tabaco 30 x 60, Boulder Tabaco 30 x 60, Kavala Marrón. ≡ Pavimento: Homestone Tabaco 60 x 60.

medida cm	nºpzax/box	m²/box	kg/box	boxes/pallet	m²/pallet	kg/pallet
45x90	3	1,22	30,50	27	32,94	823,50
60x60	3	1,08	25,75	32	34,56	824,00
45x45	5	1,01	23,30	66	66,66	1.537,80
30x60	6	1,08	24,80	40	43,20	992,00
30x30 mallado	11	1,00	20,00	36	36,00	720,00

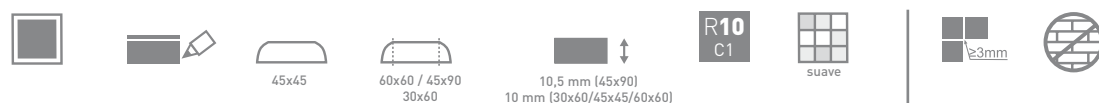

ICARIA 60X60 23<sup>5/8</sup>"X23<sup>5/8</sup>" 45X45 17<sup>3/4</sup>"X17<sup>3/4</sup>" 30X60 11<sup>13/16</sup>"X23<sup>5/8</sup>" 30X30 11<sup>13/16</sup>"X11<sup>13/16</sup>"



BLANCO IV



BEIGE IV



ANTRACITA IV



OCRE IV

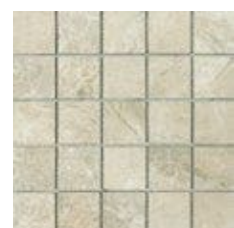

30x30 Dedalo  
Beige **41DE-70** (09-05)  
Blanco **41DE-40** (09-05)  
Ocre **41DE-00** (09-05)  
Antracita **41DE-50** (09-05)



7,5x7,5  
Taco Metal 1  
**06TAME1** (12-81)



7,5x7,5  
Taco Metal 2  
**06TAME2** (12-81)



7,5x7,5  
Taco Metal 3  
**06TAME3** (12-81)



60x60 Icaria  
Blanco **52IC45R** (07-83)  
Beige **52IC75R** (07-83)  
Ocre **52IC05R** (07-83)  
Antracita **52IC55R** (07-83)

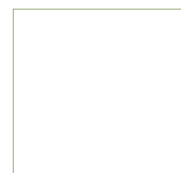

45x45 Icaria  
Blanco **42IC-48** (07-74)  
Beige **42IC-78** (07-74)  
Ocre **42IC-08** (07-74)  
Antracita **42IC-58** (07-74)

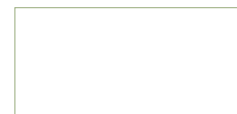

30x60 Icaria  
Blanco **46IC-42** (07-81)  
Beige **46IC-72** (07-81)  
Ocre **46IC-02** (07-81)  
Antracita **46IC-52** (07-81)



30x30 Icaria  
Blanco **41IC-40** (07-60)  
Beige **41IC-70** (07-60)  
Ocre **41IC-00** (07-60)  
Antracita **41IC-50** (07-60)



Peldaño Escuadra Ang.  
30x30 [20-60]  
30x60 [20-70]

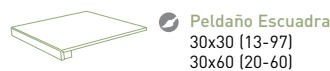

Peldaño Escuadra  
30x30 [13-97]  
30x60 [20-60]



Rodapié  
8x45 [11-08]  
8x60 [12-46]



Pavimento: Icaria Beige 60 x 60.

medida cm	nºpzax/box	m²/box	kg/box	boxes/pallet	m²/pallet	kg/pallet
60x60	3	1,08	25,75	32	34,56	824,00
45x45	5	1,01	23,30	66	66,66	1.537,80
30x60	6	1,08	24,80	40	43,20	992,00
30x30	10	0,90	20,70	48	43,20	993,60
30x30 mallado	11	1,00	20,00	36	36,00	720,00



KATMANDU 60X60 23<sup>5/8</sup>"X23<sup>5/8</sup>" 30X60 11<sup>13/16</sup>"X23<sup>5/8</sup>"



NATURAL IV



ARENA IV



MINERAL IV



TABACO IV



ANTRACITA IV



III Revestimiento: Katmandu 30 x 60 Natural, Masala Clear 30 x 60. ≡ Pavimento: Katmandu Natural 60 x 60.

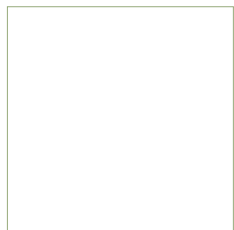

60x60 Katmandu  
Natural 52KA45R (07-83)  
Arena 52KA75R (07-83)  
Mineral 52KA35R (07-83)  
Tabaco 52KA25R (07-83)  
Antracita 52KA65R (07-83)



30x60 Katmandu  
Natural 46KA42R (07-77)  
Arena 46KA72R (07-77)  
Mineral 46KA32R (07-77)  
Tabaco 46KA22R (07-77)  
Antracita 46KA62R (07-77)

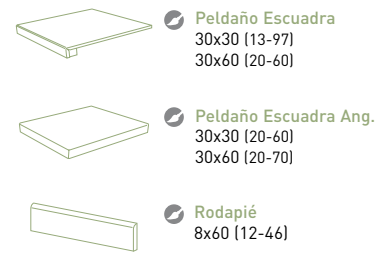

Peldaño Escuadra  
30x30 (13-97)  
30x60 (20-60)

Peldaño Escuadra Ang.  
30x30 (20-60)  
30x60 (20-70)

Rodapié  
8x60 (12-46)



60x60 Bagmati  
Clear 52KA015 (08-05) IV



60x60 Bagmati  
Dark 52KA915 (08-05) IV



60x60 Bagmati  
Antracita 52KA615 (08-05) IV



30x60 Masala  
Clear 46KA012 (08-30) IV



30x60 Masala  
Dark 45KA912 (08-30) IV



30x60 Masala  
Antracita 45KA612 (08-30) IV

medida cm	nºpzax/box	m²/box	kg/box	boxes/pallet	m²/pallet	kg/pallet
60x60	3	1,08	25,75	32	34,56	824,00
30x60	6	1,08	24,80	40	43,20	992,00



LIEJA 60X60 23<sup>5</sup>/<sub>8</sub>"X23<sup>5</sup>/<sub>8</sub>"

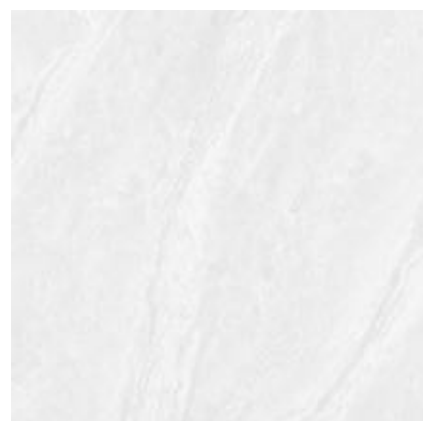

BLANCO

IV



CREMA

IV



NEGRO

IV



MARRÓN

IV

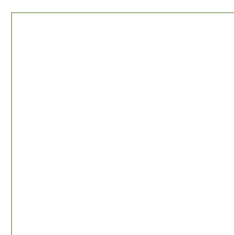

60x60 Lieja  
Blanco 52LI45P (07-90)  
Crema 52LI05P (07-90)  
Marrón 52LI25P (07-90)  
Negro 52LI95P (07-90)

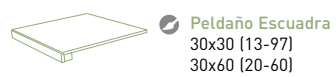

● Peldaño Escuadra  
30x30 (13-97)  
30x60 (20-60)

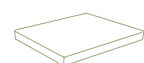

● Peldaño Escuadra Ang.  
30x30 (20-60)  
30x60 (20-70)



● Rodapié  
8x60 (12-65)



≡ Pavimento: Lieja Marrón 60 x 60.



60 x 60



10 mm



R9  
C1



suave



3mm

medida cm	nºzas/box	m <sup>2</sup> /box	kg/box	boxes/pallet	m <sup>2</sup> /pallet	kg/pallet
60x60	3	1,08	25,75	32	34,56	824,00



PALACE MERCURE 59X119 23<sup>1/4</sup>"X46<sup>7/8</sup>" 78X78 30<sup>3/4</sup>"X 30<sup>3/4</sup>"

NUEVO NEW



PALACE MERCURE GRIS III



PALACE MERCURE BLANCO III



LIEBANA 59X119 58PM31P (06-95) III



LIEBANA 78X78 61PM31P (06-95) III



78x78 Palace  
Mercure Gris **61PM36P** (06-82)  
Mercure Blanco **61PM46P** (06-82)

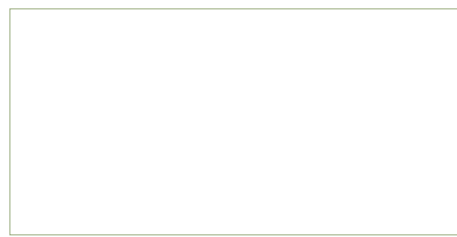

59x119 Palace  
Mercure Gris **58PM39P** (06-85)  
Mercure Blanco **58PM49P** (06-85)

medida cm	nºzas/box	m²/box	kg/box	boxes/pallet	m²/pallet	kg/pallet
59x119	2	1,40	41,50	25	35,00	1.037,50
78X78	2	1,28	34,25	40	51,20	1.370,00

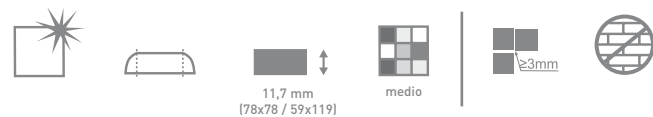



Building Directory

- 3 Management
- 2 Accounting
- 1 Administration
- 0 Reception



PALACE PORT LAURENT III



59x119 Liebana 58PM31P (06-95) III



78x78 Liebana 61PM31P (06-95) III

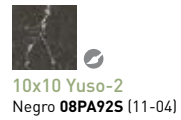

10x10 Yuso-2 Negro 08PA92S (11-04)



10x59 Yuso-1 Negro 08PA91S (12-70)



10x119 Yuso-3 Negro 08PA93S (13-76)



10x10 Yuste-2 Blanco 08PA42Y (11-04)

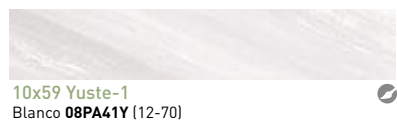

10x59 Yuste-1 Blanco 08PA41Y (12-70)



10x119 Yuste-3 Blanco 08PA43Y (13-76)

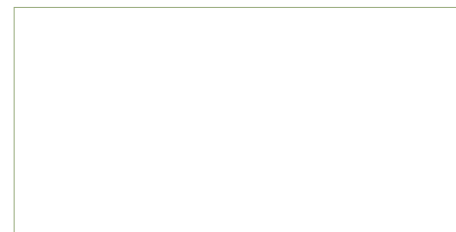

59x119 Palace Port Laurent 58PL99P (06-85)

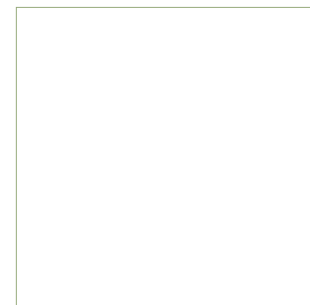

78x78 Palace Port Laurent 61PL96P (06-82)



59x119 Fontenay 58PL91P (06-95) III



78x78 Fontenay 61PL91P (06-95) III

medida cm	nºpzax/box	m²/box	kg/box	boxes/pallet	m²/pallet	kg/pallet
59x119	2	1,40	41,50	25	35,00	1.037,50
78X78	2	1,28	34,25	40	51,20	1.370,00

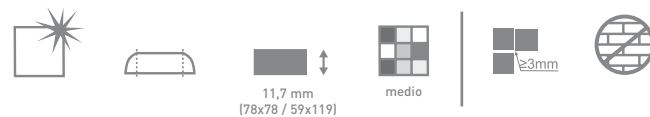







NEY YORK BLANCO IV



NEW YORK CORTEN IV



NEW YORK MARENGO IV



59x119 Broadway Blanco **58PY419** (06-95) IV



59x59 Broadway Blanco **52PY415** (06-85) IV



59x119 Broadway Corten **58PY919** (06-95) IV



59x59 Broadway Corten **52PY915** (06-85) IV

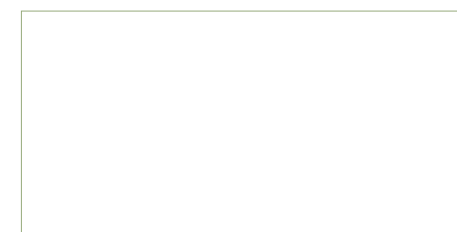

59x119 Palace New York Blanco **58PY49P** (06-85)  
Corten **58PY99P** (06-85)  
Marengo **58PY59P** (06-85)



59x59 Palace New York Blanco **52PY45P** (06-80)  
Corten **52PY95P** (06-80)  
Marengo **52PY55P** (06-80)



Rodapié 8x59 (13-04)

medida cm	nºpzax/box	m²/box	kg/box	boxes/pallet	m²/pallet	kg/pallet
59x119	2	1,40	41,50	25	35,00	1.037,50
59x59	3	1,04	26,50	32	33,28	848,00



PALACE PALISANDRO 59X119 23<sup>1</sup>/<sub>4</sub>"X46<sup>7</sup>/<sub>8</sub>" 59X59 23<sup>1</sup>/<sub>4</sub>"X23<sup>1</sup>/<sub>4</sub>"



≡ Pavimento: Palace Palisandro Antracita 59 x 119, Yuste-3 Blanco 10 x 119, Yuste- 2 Antracita 10 x 10, Yuste-1 Blanco 10x59.

PALACE PALISANDRO 59X119 23<sup>1/4</sup>"X46<sup>7/8</sup>" 59X59 23<sup>1/4</sup>"X23<sup>1/4</sup>"



PALISANDRO BLANCO V

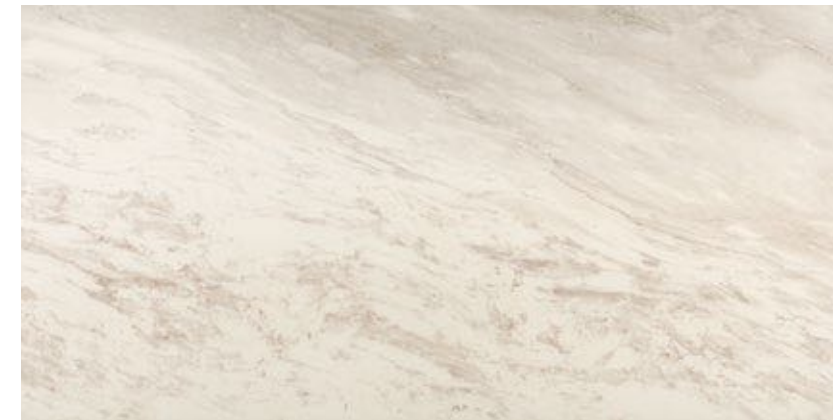

PALISANDRO BEIGE V



59x59 Rex Beige 52PARX7 (06-85)



PALISANDRO ANTRACITA III



59x59 Rex Blanco 52PARX4 (06-85)



PALISANDRO GRIS IV



59x59 Rex Gris 52PARX3 (06-85)



59x119 Rex Blanco 58PA4RX (06-95)  
Beige 58PA7RX (06-95)  
Gris 58PA3RX (06-95)



59x59 Palace Palisandro Blanco 52PP45P (06-80)  
Palisandro Beige 52PP75P (06-80)  
Palisandro Gris 52PP35P (06-80)  
Palisandro Antracita 52PP65P (06-80)

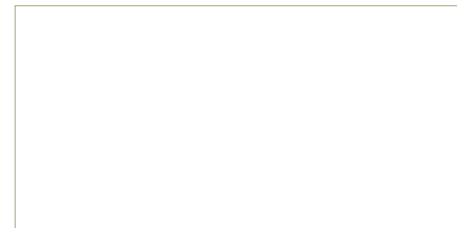

59x119 Palace Palisandro Blanco 58PP49P (06-85)  
Palisandro Beige 58PP79P (06-85)  
Palisandro Gris 58PP39P (06-85)  
Palisandro Antracita 58PP69P (06-85)



Rodapié 8x59 (13-04)



10x59 Yuste-1 Blanco 08PA41Y (12-70)  
Gris 08PA31Y (12-70)  
Antracita 08PA61Y (12-70)



10x10 Yuste-2 Blanco 08PA42Y (11-04)  
Gris 08PA32Y (11-04)  
Antracita 08PA62Y (11-04)



10x119 Yuste-3 Blanco 08PA43Y (13-76)  
Gris 08PA33Y (13-76)  
Antracita 08PA63Y (13-76)



10x59 Paular-1 Castaño 08PA01P (12-32)  
Sauce 08PA11P (12-32)



10x10 Paular-2 Castaño 08PA02P (11-00)  
Sauce 08PA12P (11-00)



10x119 Paular-3 Castaño 08PA03P (13-30)  
Sauce 08PA13P (13-30)

medida cm	nºpzax/box	m²/box	kg/box	boxes/pallet	m²/pallet	kg/pallet
59x119	2	1,40	41,50	25	35,00	1.037,50
59x59	3	1,04	26,50	32	33,28	848,00

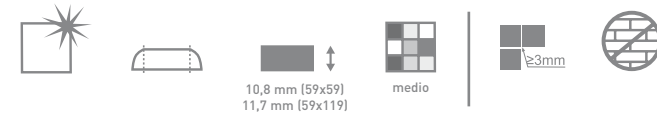

**PALACE DUNE** 59X119 23<sup>1</sup>/<sub>4</sub>"X46<sup>7</sup>/<sub>8</sub>" 59X59 23<sup>1</sup>/<sub>4</sub>"X23<sup>1</sup>/<sub>4</sub>"



DUNE V



59x59 Zeus 52PZ25P (06-85) IV



10x10 Poblet-2 08PA72T (11-04)



10x10 Paular-2 Sauce 08PA12P (11-00) Castaño 08PA02P (11-00)



10x59 Paular-1 Sauce 08PA11P (12-32) Castaño 08PA01P (12-32)



10x119 Paular-3 Sauce 08PA13P (13-30) Castaño 08PA03P (13-30)



Rodapié 8x59 (13-04)

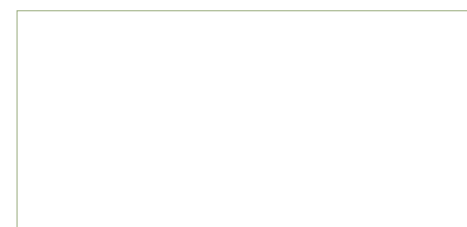

59x119 Palace Dune 58PD79P (06-85)



59x59 Palace Dune 52PD75P (06-80)



≡ Pavimento: Palace Dune 59 x 119, Paular-3 Castaño 10 x 120, Paular 2 Castaño 10 x 10

medida cm	nºpzax/box	m²/box	kg/box	boxes/pallet	m²/pallet	kg/pallet
59x119	2	1,40	41,50	25	35,00	1.037,50
59x59	3	1,04	26,50	32	33,28	848,00

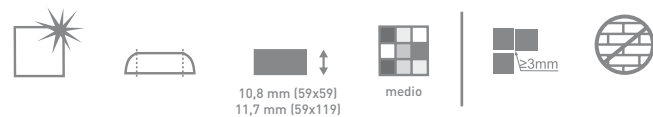

PALACE CALACATA 59X119 23<sup>1/4</sup>"X46<sup>7/8</sup>" 59X59 23<sup>1/4</sup>"X23<sup>1/4</sup>" 9,5X28 3<sup>15/16</sup>"X 11<sup>7/32</sup>"



PALACE AGATA 59X119 23<sup>1</sup>/<sub>4</sub>" X 46<sup>7</sup>/<sub>8</sub>" 59X59 23<sup>1</sup>/<sub>4</sub>" X 23<sup>1</sup>/<sub>4</sub>"



≡ Pavimento: Palace Agata Beige 59 x 59, Ambras 3 Beige, Ambras 2 Beige, Ambras 1 Beige.

**PALACE CALACATA** 59X119 23<sup>1/4</sup>"X46<sup>7/8</sup>" 59X59 23<sup>1/4</sup>"X23<sup>1/4</sup>" 9,5X28 3<sup>15/16</sup>"X 11<sup>7/32</sup>"



CALACATA



59x59 Padova 3  
52PAD45 (06-85)



8,5x59 Padova 1  
08PAD01 (13-05)



8,5x8,5 Padova 2  
08PAD02 (11-00)



30x30 Mantova  
41PC40M (09-35)



28x29 Ravenna  
08RA-40 (13-81)



59x59 Trento  
Blanco 52TRE45 (06-85)



25x25 Forti  
08FO-40 (13-72)



2,5x28 Torello Palace Calacata  
08TPACA (11-40)

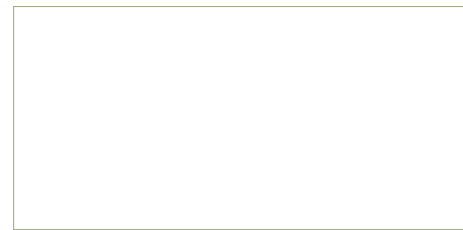

59x119 Palace  
Calacata 58PC49P (06-85)  
Agata Blanco 58PG49P (06-85)  
Agata Beige 58PG79P (06-85)  
Agata Gris 58PG39P (06-85)



59x59 Palace  
Calacata 52PC45P (06-80)  
Agata Blanco 52PG45P (06-80)  
Agata Beige 52PG75P (06-80)  
Agata Gris 52PG35P (06-80)



9,5x28 Palace  
Calacata 57PC40L (06-90)



Rodapié  
8x59 (13-04)

**PALACE AGATA** 59X119 23<sup>1/4</sup>"X46<sup>7/8</sup>" 59X59 23<sup>1/4</sup>"X23<sup>1/4</sup>"



AGATA BLANCO



AGATA GRIS



AGATA BEIGE



30 x 30 Musa Damasco  
Negro 69MU-DN (40-70)



30 x 30 Musa Cristal Oro  
69MU-CR (40-75)



30 x 30 Musa Carrara  
69MU-CA (40-40)



59x59 Topkapi 3  
Blanco 08TOP43 (20-18)  
Gris 08TOP33 (20-18)  
Beige 08TOP73 (20-18)



9,6x59 Topkapi 1  
Blanco 08TOP41 (13-65)  
Gris 08TOP31 (13-65)  
Beige 08TOP71 (13-65)



9,6x9,6 Topkapi 2  
Blanco 08TOP42 (12-22)  
Gris 08TOP32 (12-22)  
Beige 08TOP72 (12-22)



59x59 Ambras 3  
Blanco 08AM-43 (20-75)  
Gris 08AM-33 (20-75)  
Beige 08AM-73 (20-75)



9,6x59 Ambras 1  
Blanco 08AM-41 (13-69)  
Gris 08AM-31 (13-69)  
Beige 08AM-71 (13-69)



9,6x9,6 Ambras 2  
Blanco 08AM-42 (12-50)  
Gris 08AM-32 (12-50)  
Beige 08AM-72 (12-50)

medida cm	nºpzax/box	m²/box	kg/box	boxes/pallet	m²/pallet	kg/pallet
59x119	2	1,40	41,50	25	35,00	1.037,50
59x59	3	1,04	26,50	32	33,28	848,00
28x59	6	0,99	25,75	40	39,60	1.030,00
9,5x28	9	0,24	5,27	100	26,5	50,00

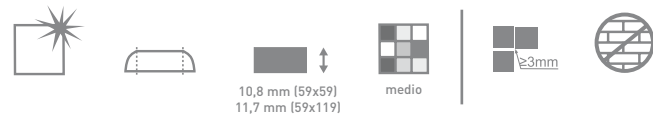

10,8 mm [59x59]  
11,7 mm [59x119]

medio

≤3mm



**PALACE** 59X119 23<sup>1</sup>/<sub>4</sub>" X46<sup>7</sup>/<sub>8</sub>" 59X59 23<sup>1</sup>/<sub>4</sub>" X23<sup>1</sup>/<sub>4</sub>"

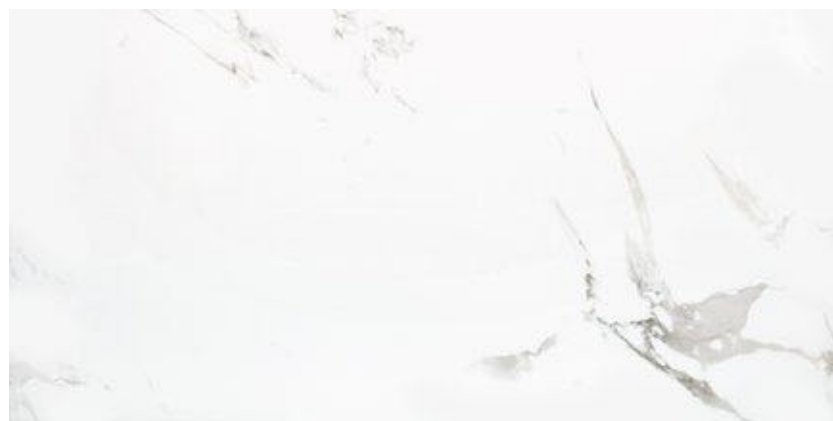

CARRARA

IV

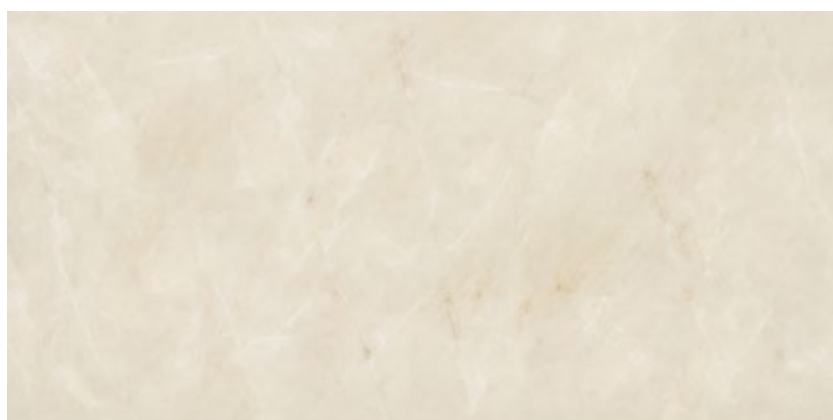

MADRÁS

IV



CREMA

IV



INDALO

IV

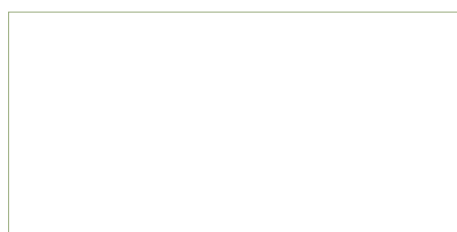

59x119 Palace  
 Crema **58PA69P** (06-85)  
 Madrás **58PA09P** (06-85)  
 Indalo **58PA79P** (06-85)  
 Carrara **58PA49P** (06-85)

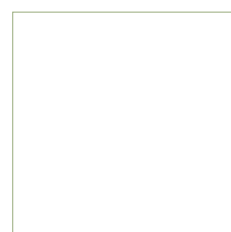

59x59 Palace  
 Madrás **52PA05P** (06-80)  
 Indalo **52PA75P** (06-80)  
 Carrara **52PA45P** (06-80)  
 Rodas **52PR95P** (06-80)



8x59 Leyre-1  
 Madrás **08LE-01** (12-50)  
 Indalo **08LE-71** (12-50)  
 Carrara **08LE-41** (12-50)  
 Rodas **08LE-91** (12-50)



8x8 Leyre-2  
 Madrás **08LE-02** (11-00)  
 Indalo **08LE-72** (11-00)  
 Carrara **08LE-42** (11-00)  
 Rodas **08LE-92** (11-00)



≡ Pavimento: Rodas 59 x 59.

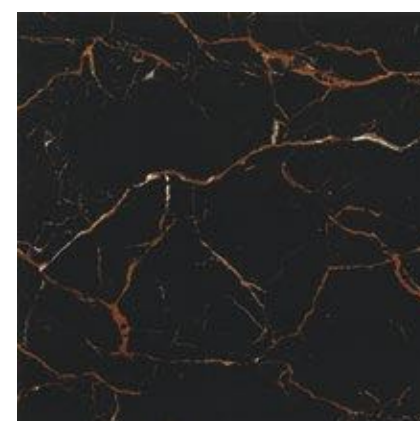

RODAS

III



59x59 Coloso 2  
 Rodas **52PA92C** (20-75)  
 Madrás **52PA02C** (20-75)



59x59 Coloso 1  
 Madrás **52PA01C** (20-75)  
 Rodas **52PA91C** (20-75)



Rodapié  
 8x59 (13-04)

medida cm	nºpzax/box	m²/box	kg/box	boxes/pallet	m²/pallet	kg/pallet
59x119	2	1,40	41,50	25	35,00	1.037,50
59x59	3	1,04	26,50	32	33,28	848,00

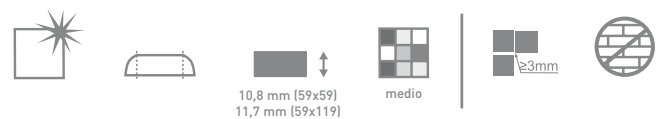

**PATAGONIA** 19,5X120 7<sup>10/16</sup>"X47<sup>11/16</sup>" 14,5X120 5<sup>23/32</sup>"X47<sup>11/16</sup>"  
 60X60 23<sup>5/8</sup>"X23<sup>5/8</sup>" **20MM** 30X120 11<sup>13/16</sup>"X47<sup>11/16</sup>" **20MM**



FRESNO

IV



ROBLE

IV



CASTAÑO

IV



AZAHAR

IV



ENCINA

IV



ÉBANO

IV

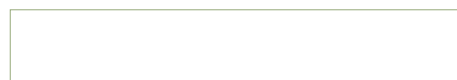

19,5x120 Patagonia  
 Fresno **59PA59T** (05-80)  
 Roble **59PA79T** (05-80)  
 Castaño **59PA89T** (05-80)  
 Azahar **59PA49T** (05-80)  
 Encina **59PA19T** (05-80)  
 Ébano **59PA99T** (05-80)

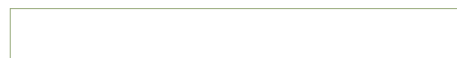

14,5x120 Patagonia  
 Fresno **59PA59L** (05-80)  
 Roble **59PA79L** (05-80)  
 Castaño **59PA89L** (05-80)  
 Azahar **59PA49L** (05-80)  
 Encina **59PA19L** (05-80)  
 Ébano **59PA99L** (05-80)

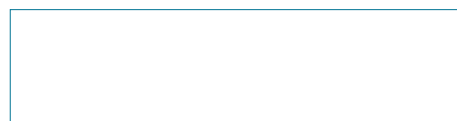

30x120 Patagonia **20MM**  
 Fresno **59PT59M** (96-70)  
 Castaño **59PT89M** (96-70)  
 Encina **59PT19M** (96-70)

**20MM**

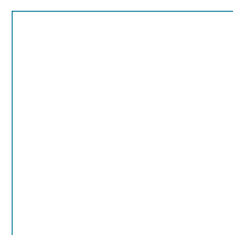

60x60 Patagonia **20MM**  
 Fresno **52PT55R** (96-60)  
 Castaño **52PT85R** (96-60)  
 Encina **52PT15R** (96-60)

**20MM**



15x80 Recife  
 Fresno **50RE-51** (00-95)  
 Roble **50RE-71** (00-95)  
 Castaño **50RE-81** (00-95)  
 Azahar **50RE-41** (00-95)  
 Encina **50RE-11** (00-95)  
 Ébano **50RE-91** (00-95)

IV



45x45 Bahia  
 Fresno **42BA-58** (00-92)  
 Roble **42BA-78** (00-92)  
 Castaño **42BA-88** (00-92)  
 Azahar **42BA-48** (00-92)  
 Encina **42BA-18** (00-92)  
 Ébano **42BA-98** (00-92)

IV

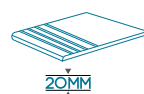

☑ Peldaño Porcelánico  
 Romo Huella  
 30x60 (13-81)  
 30x120 (20-14)

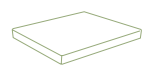

☑ Peldaño Escuadra Ang.  
 120 x 30 (20-90)  
 30 x 30 (20-60)

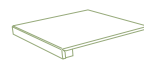

☑ Peldaño Escuadra  
 120 x 30 (20-80)  
 30 x 30 (13-97)



☑ Rodapié  
 8 x 60 (12-65)



≡ Pavimento: Patagonia Castaño 19,5 x 120.

medida cm	nºpzax/box	m²/box	kg/box	boxes/pallet	m²/pallet	kg/pallet
30x120 20MM	2	0,72	33,50	20	14,40	670,00
60x60 20MM	2	0,73	33,50	32	23,36	1.072,00
19,5x120	5	1,17	31,50	36	42,12	1.134,00
14,5x120	7	1,22	33,50	32	39,04	1.072,00



SHERWOOD 19,5X120 7<sup>10</sup>/<sub>16</sub>"X47<sup>11</sup>/<sub>16</sub>" 14,5X120 5<sup>23</sup>/<sub>32</sub>"X47<sup>11</sup>/<sub>16</sub>" 15X80 5<sup>7</sup>/<sub>8</sub>"X31<sup>1</sup>/<sub>2</sub>"



≡ Pavimento: Sherwood Nogal 19,5 x 120 / 14,5 X 120.

**SHERWOOD** 19,5X120 7<sup>10/16</sup>"X47<sup>11/16</sup>" 14,5X120 5<sup>23/32</sup>"X47<sup>11/16</sup>" 15X80 5<sup>7/8</sup>"X31<sup>1/2</sup>"



NOGAL IV



ROBLE IV



HAYA IV



CEDRO IV



19,5x120 Sherwood  
 Nogal **59SH99T** (05-88)  
 Roble **59SH29T** (05-88)  
 Haya **59SH79T** (05-88)  
 Cedro **59SH39T** (05-88)



14,5x120 Sherwood  
 Nogal **59SH99L** (05-88)  
 Roble **59SH29L** (05-88)  
 Haya **59SH79L** (05-88)  
 Cedro **59SH39L** (05-88)

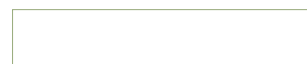

15x80 Sherwood  
 Nogal **50SH-91** (00-87)  
 Roble **50SH-21** (00-87)  
 Haya **50SH-71** (00-87)  
 Cedro **50SH-31** (00-87)

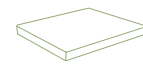
-  **Peldaño Escuadra**  
30x30 (13-97)  
120x30 (20-80)
-  **Peldaño Escuadra Ang.**  
30x30 (20-60)  
120x30 (20-90)
-  **Rodapié**  
8x60 (12-65)  
8x30 (10-65)



≡ Pavimento: Sherwood Nogal 19,5 x 120.

medida cm	nºpzax/box	m²/box	kg/box	boxes/pallet	m²/pallet	kg/pallet
19,5x120	5	1,17	31,50	36	42,12	1.134,00
14,5x120	7	1,22	33,50	32	39,04	1.072,00
15x80	9	1,08	26,00	48	51,84	1.248,00

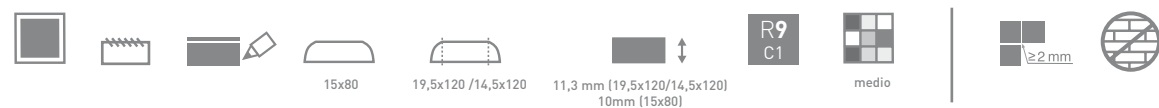

SIDNEY 80X80 31 1/2"X31 1/2" 60X60 23 5/8"X23 5/8"

NUEVO NEW



PORCELÁNICO PORCELAIN TILES

SIDNEY 80X80 31 1/2"X31 1/2" 60X60 23 5/8"X23 5/8"

NUEVO NEW



BLANCO IV

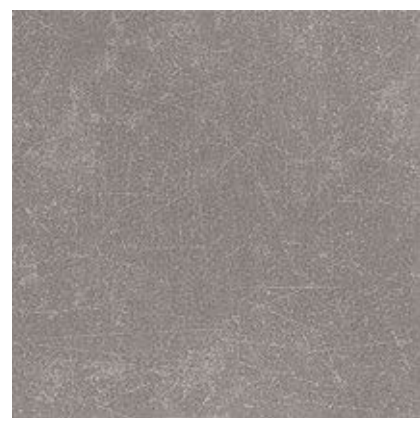

SILVER IV



OXIDO IV



GRAFITO IV

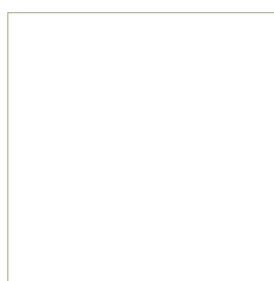

80x80 Sidney  
Blanco **61SN46P** (06-08)  
Silver **61SN36P** (06-08)  
Grafito **61SN96P** (06-08)  
Oxido **61SN26P** (06-08)

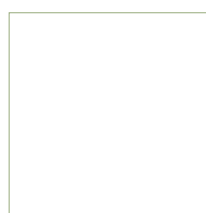

60x60 Sidney  
Blanco **52SN45P** (07-91)  
Silver **52SN35P** (07-91)  
Grafito **52SN95P** (07-91)  
Oxido **52SN25P** (07-91)

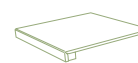

Peldaño Escuadra  
30x30 (13-97)  
30x80 (20-40)

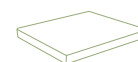

Peldaño Escuadra Ang.  
30x30 (20-60)  
30x80 (20-50)



Rodapié  
8x60 (12-65)  
8x80 (13-04)



Pavimento: Sidney Grafito 80x80

medida cm	nºpzax/box	m²/box	kg/box	boxes/pallet	m²/pallet	kg/pallet
80x80	2	1,28	34,25	40	51,20	1.370,00
60x60	3	1,08	25,75	32	34,56	824,00

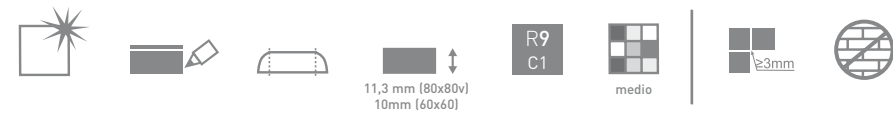

SINTRA 45X45 17<sup>3</sup>/<sub>4</sub>"X17<sup>3</sup>/<sub>4</sub>" 30X60 11<sup>13</sup>/<sub>16</sub>"X23<sup>5</sup>/<sub>8</sub>" 30X30 11<sup>13</sup>/<sub>16</sub>"X11<sup>13</sup>/<sub>16</sub>"



BEIGE IV



GRIS IV



ANTRACITA IV



≡ Pavimento: Sintra Beige 45 x 45.



30x30 Queluz  
Antracita 41SI50M (09-05)  
Gris 41SI30M (09-05)  
Beige 41SI70M (09-05)



30x30 Amadora  
Antracita 41SI50A (13-05)  
Gris 41SI30A (13-05)  
Beige 41SI70A (13-05)



7,5x7,5  
Taco Metal 1  
06TAME1 (12-81)



7,5x7,5  
Taco Metal 2  
06TAME2 (12-81)



7,5x7,5  
Taco Metal 3  
06TAME3 (12-81)



45x45 Sintra  
Beige 42SI-78 (07-69)  
Gris 42SI-38 (07-69)  
Antracita 42SI-58 (07-69)

45x45 Sintra Antislip  
Beige 42SIA78 (07-75)  
Gris 42SIA38 (07-75)  
Antracita 42SIA58 (07-75)

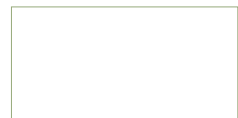

30x60 Sintra  
Antracita 46SI-52 (07-69)  
Gris 46SI-32 (07-69)  
Beige 46SI-72 (07-69)

30x60 Sintra Antislip  
Antracita 46SIA52 (07-75)  
Gris 46SIA32 (07-75)  
Beige 46SIA72 (07-75)



30x30 Sintra  
Beige 41SI-70 (07-60)  
Gris 41SI-30 (07-60)  
Antracita 41SI-50 (07-60)

30x30 Sintra Antislip  
Beige 41SIA70 (07-69)  
Gris 41SIA30 (07-69)  
Antracita 41SIA50 (07-69)



Peldaño Escuadra  
30 x 30 (13-97)  
30 x 60 (20-60)

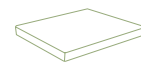

Peldaño Escuadra Ang.  
30 x 30 (20-60)  
30 x 60 (20-70)



Rodapié  
8 x 30 (10-65)  
8 x 45 (11-04)

≡ Pavimento: Sintra Gris 45 x 45, 30 x 60 y 30 x 30.

≡ Revestimiento: Cubana Bambú 14,5 x 120.

medida cm	nºpzax/box	m <sup>2</sup> /box	kg/box	boxes/pallet	m <sup>2</sup> /pallet	kg/pallet
45x45	5	1,01	23,30	66	66,66	1.537,80
30x60	6	1,08	24,80	40	43,20	992,00
30x30	10	0,90	20,70	48	43,20	993,60
30x30 mallado	11	1,00	20,00	36	36,00	720,00



SKYLINE 45X90 17<sup>3</sup>/<sub>4</sub>"X35<sup>7</sup>/<sub>16</sub>" 60X60 23<sup>5</sup>/<sub>8</sub>"X23<sup>5</sup>/<sub>8</sub>" 45X45 17<sup>3</sup>/<sub>4</sub>"X17<sup>3</sup>/<sub>4</sub>" 30X60 11<sup>13</sup>/<sub>16</sub>"X23<sup>5</sup>/<sub>8</sub>"



BLANCO IV



BEIGE IV



GRIS IV



MARENGO IV

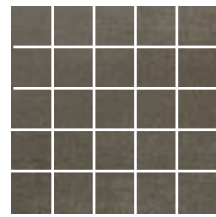

30x30 Waldorf  
Marengo 41WA-50 (09-05)  
Blanco 41WA-40 (09-05)  
Beige 41WA-70 (09-05)  
Gris 41WA-30 (09-05)



60x60 Skyline  
Blanco 52SK45R (07-82)  
Beige 52SK75R (07-82)  
Gris 52SK35R (07-82)  
Marengo 52SK55R (07-82)

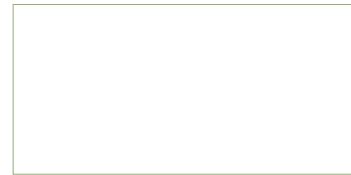

45x90 Skyline  
Blanco 54SK47R (07-92)  
Beige 54SK77R (07-92)  
Gris 54SK37R (07-92)  
Marengo 54SK57R (07-92)



45x45 Skyline  
Blanco 42SK-48 (07-60)  
Beige 42SK-78 (07-60)  
Gris 42SK-38 (07-60)  
Marengo 42SK-58 (07-60)

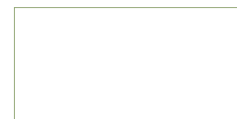

30x60 Skyline  
Blanco 46SK-42 (07-66)  
Beige 46SK-72 (07-66)  
Gris 46SK-32 (07-66)  
Marengo 46SK-52 (07-66)

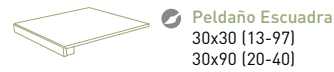

Peldaño Escuadra  
30x30 (13-97)  
30x90 (20-40)

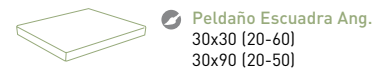

Peldaño Escuadra Ang.  
30x30 (20-60)  
30x90 (20-50)



Rodapié  
8x45 (11-08)  
8x60 (12-46)



III Revestimiento: Skyline Blanco 22 x 90, Waldorf Blanco 30 x 30 III Revestimiento: Kenai Negro 30 x 30 III Pavimento: Skyline Blanco 60 x 60

medida cm	nºpzax/box	m²/box	kg/box	boxes/pallet	m²/pallet	kg/pallet
45x90	3	1,22	30,50	27	32,94	823,50
45x45	5	1,01	23,30	66	66,66	1.537,80
60x60	3	1,08	25,75	32	34,56	824,00
30x60	6	1,08	25,80	40	43,20	1.032,00

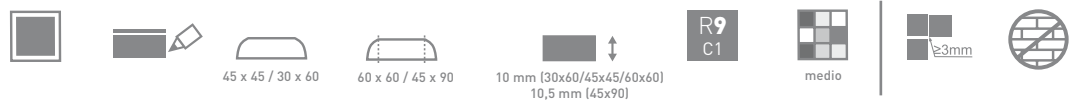



TEMPO 80X80 31<sup>1</sup>/<sub>2</sub>"X31<sup>1</sup>/<sub>2</sub>" 60X60 23<sup>5</sup>/<sub>8</sub>"X23<sup>5</sup>/<sub>8</sub>" 30X60 11<sup>13</sup>/<sub>16</sub>"X23<sup>5</sup>/<sub>8</sub>"



III Revestimiento: Tempo Gris 30 x 60, Canyon Gris 30 x 60. ≡ Pavimento: Tempo Gris 60 x 60, Carpet 2 60 x 60.

TEMPO 80X80 31<sup>1</sup>/<sub>2</sub>"X31<sup>1</sup>/<sub>2</sub>" 60X60 23<sup>5</sup>/<sub>8</sub>"X23<sup>5</sup>/<sub>8</sub>" 30X60 11<sup>13</sup>/<sub>16</sub>"X23<sup>5</sup>/<sub>8</sub>"



GRIS IV



SMOKE IV



ANTRACITA IV



30x60 Canyon Gris 46TM322 (07-71) IV



30x60 Canyon Smoke 46TM222 (07-71) III



30x60 Canyon Antracita 46TM622 (07-71) III



60x60 Carpet 2 52TM315 (07-89) IV



30x60 Carpet 1 46TM312 (07-71) IV



30x30 Pulso Antracita 41TM60P (09-05) Gris 41TM30P (09-05) Smoke 41TM20P (09-05)

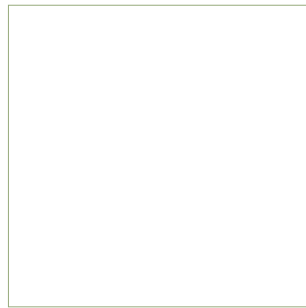

80x80 Tempo Antracita 61TM66R (06-07) Gris 61TM36R (06-07) Smoke 61TM26R (06-07)

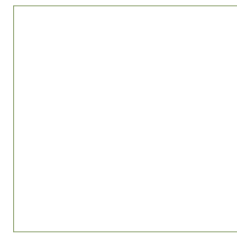

60x60 Tempo Antracita 52TM65R (07-83) Gris 52TM35R (07-83) Smoke 52TM25R (07-83)

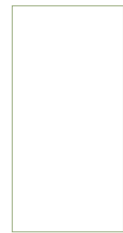

30x60 Tempo Antracita 46TM-62 (07-66) Gris 46TM-32 (07-66) Smoke 46TM-22 (07-66)

30x60 Tempo Antislip Antracita 46TMA62 (07-75) Gris 46TMA32 (07-75) Smoke 46TMA22 (07-75)



Peldaño Escuadra 30x30 (13-97) 30x60 (20-60)

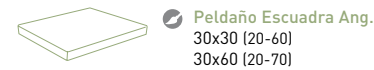

Peldaño Escuadra Ang. 30x30 (20-60) 30x60 (20-70)



Rodapié 8x60 (12-46) 8x80 (13-04)

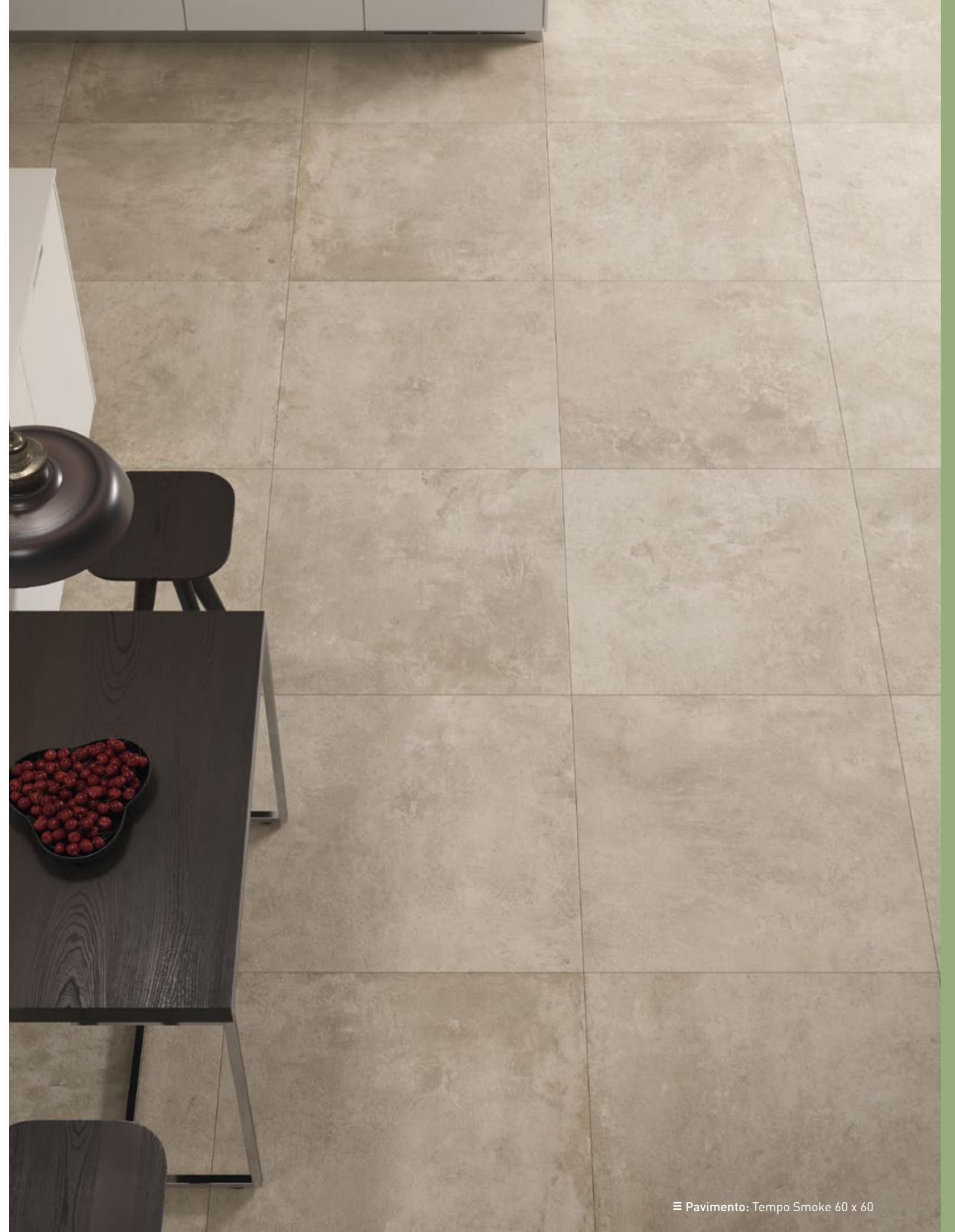

≡ Pavimento: Tempo Smoke 60 x 60

medida cm	nºpzax/box	m²/box	kg/box	boxes/pallet	m²/pallet	kg/pallet
80x80	2	1,28	34,25	40	51,20	1.370,00
60x60	3	1,08	25,75	32	34,56	824,00
30x60	6	1,08	25,80	40	43,20	1.032,00

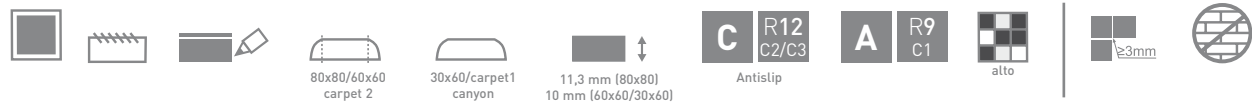

VULCANO 80X80 31<sup>1</sup>/<sub>2</sub>"X31<sup>1</sup>/<sub>2</sub>" 60X60 23<sup>5</sup>/<sub>8</sub>"X23<sup>5</sup>/<sub>8</sub>" 40X80 15<sup>6</sup>/<sub>4</sub>"X31<sup>1</sup>/<sub>2</sub>" 15X15 5<sup>7</sup>/<sub>8</sub>" X5<sup>7</sup>/<sub>8</sub>"

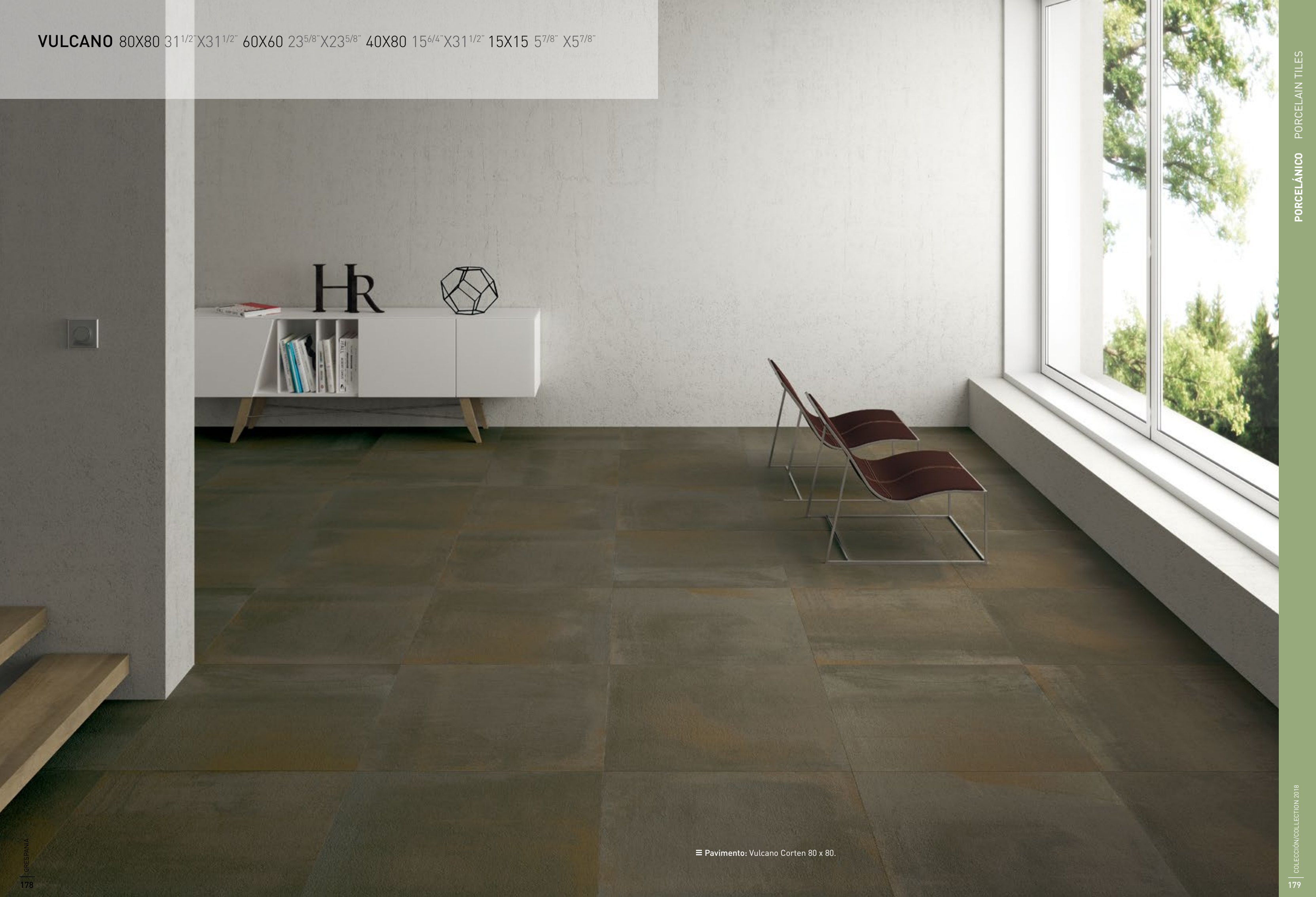

≡ Pavimento: Vulcano Corten 80 x 80.

VULCANO 80X80 31<sup>1</sup>/<sub>2</sub>"X31<sup>1</sup>/<sub>2</sub>" 60X60 23<sup>5</sup>/<sub>8</sub>"X23<sup>5</sup>/<sub>8</sub>" 40X80 15<sup>6</sup>/<sub>4</sub>"X31<sup>1</sup>/<sub>2</sub>" 15X15 5<sup>7</sup>/<sub>8</sub>" X5<sup>7</sup>/<sub>8</sub>"



CORTEN



IRON



60x60 Fragua  
Corten **52FGP25** (07-94)  
Iron **52FGP95** (07-94)  
Galena **52FGP65** (07-94)  
Silver **52FGP35** (07-94)



GALENA



SILVER

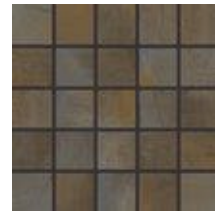

30x30 Juno  
Corten **41VL20J** (09-05)  
Iron **41VL90J** (09-05)  
Galena **41VL60J** (09-05)  
Silver **41VL30J** (09-05)



19,2x38,4 Saturno  
Corten **08SA-20** (13-71)  
Iron **08SA-90** (13-71)  
Galena **08SA-60** (13-71)  
Silver **08SA-30** (13-71)

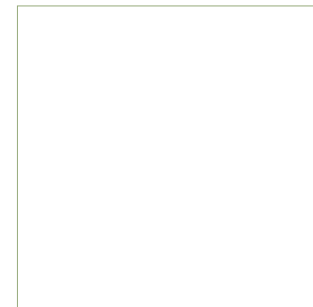

80x80 Vulcano natural  
Corten **61VLR26** (06-07)  
Iron **61VLR96** (06-07)  
Galena **61VLR66** (06-07)  
Silver **61VLR36** (06-07)



40x80 Vulcano natural  
Corten **61VLR23** (06-07)  
Iron **61VLR93** (06-07)  
Galena **61VLR63** (06-07)  
Silver **61VLR33** (06-07)

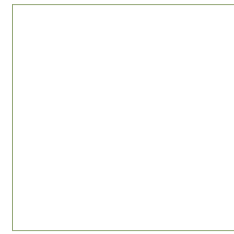

60x60 Vulcano natural  
Corten **52VLR25** (08-05)  
Iron **52VLR95** (08-05)  
Galena **52VLR65** (08-05)  
Silver **52VLR35** (08-05)



15x15 Vulcano natural  
Corten **06TVU20** (05-12)  
Iron **06TVU90** (05-12)  
Galena **06TVU60** (05-12)  
Silver **06TVU30** (05-12)

80x80 Vulcano pulido  
Corten **61VLP26** (06-08)  
Iron **61VLP96** (06-08)  
Galena **61VLP66** (06-08)  
Silver **61VLP36** (06-08)

40x80 Vulcano pulido  
Corten **61VLP23** (06-08)  
Iron **61VLP93** (06-08)  
Galena **61VLP63** (06-08)  
Silver **61VLP33** (06-08)

60x60 Vulcano pulido  
Corten **52VLP25** (07-94)  
Iron **52VLP95** (07-94)  
Galena **52VLP65** (07-94)  
Silver **52VLP35** (07-94)



Peldaño Escuadra  
30x30 (13-97)  
30x60 (20-60)

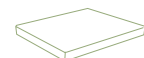

Peldaño Escuadra Ang.  
30x30 (20-60)  
30x60 (20-70)



Rodapié  
8x60 (12-65)  
8x80 (13-04)

≡ Pavimento: Vulcano Silver 80 x 80, Fragua Silver 60 x 60. ≡ Revestimiento: Vulcano Silver 40 x 80, Saturno Silver 19,2 x 38,4.

medida cm	nºpzax/box	m²/box	kg/box	boxes/pallet	m²/pallet	kg/pallet
80x80	2	1,28	34,25	40	51,20	1.370,00
40x80	3	0,96	26,75	30	28,80	802,50
60x60	3	1,08	25,75	32	34,56	824,00
15x15	20	0,45	7,80	100	-	-



PAVIMENTO  
FLOOR TILES

REVÊTEMENT DE SOL  
BODENFLIESEN  
PAVIMENTO  
PŁYTKI PODŁOGOWE  
VLOERTEGELS  
НАПОЛЬНОЕ ПОКРЫТИЕ

30X30 11<sup>13/16</sup>" X 11<sup>13/16</sup>"

JOLLY  
TURKANA

184  
185

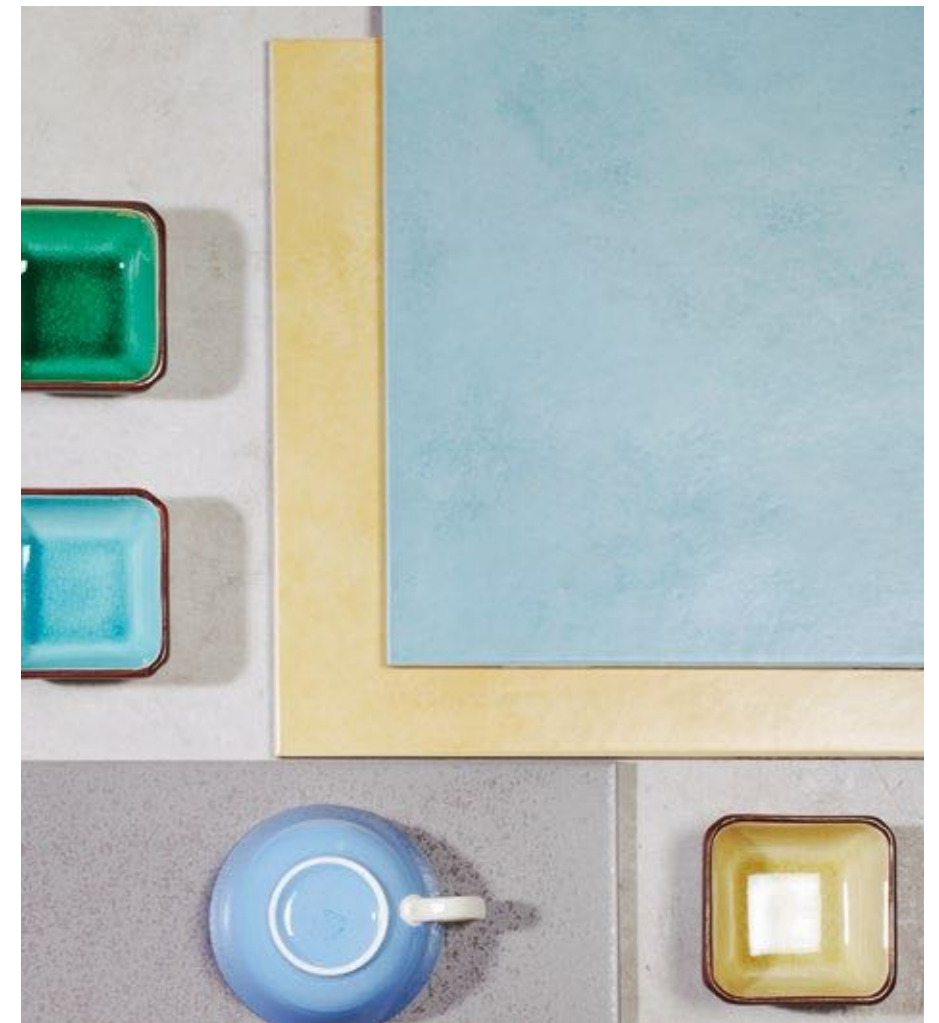

# JOLLY 30X30 11<sup>13/16</sup>"X11<sup>13/16</sup>"

 BLANCO IV	 BEIGE IV	 VERDE IV	 AZUL IV
 PERLA IV	 NUEZ IV	 PISTACHO IV	 MARINO IV
 GRIS IV	 CACAO IV	 PRUSIA IV	 AMATISTA IV Azul <b>35JO-66</b> (00-80) Marino <b>35JO-16</b> (00-80) Amatista <b>35JO-D6</b> (00-80)
 ANTRACITA IV	 MARRÓN IV	 ROJO III	
 NEGRO III	 NARANJA IV	 MAGENTA IV	

Blanco **35JO-46** (00-80)  
Perla **35JO-56** (00-80)  
Gris **35JO-36** (00-80)  
Nogal **35JO-66** (00-80)  
Antracita **35JO-96** (00-80)  
Negro **35JO-E6** (00-80)

Verde **35JO-V6** (00-80)  
Pistacho **35JO-P6** (00-80)  
Prusia **35JO-U6** (00-80)  
Rojo **35JO-R6** (00-80)  
Magenta **35JO-T6** (00-80)

Beige **35JO-76** (00-80)  
Nuez **35JO-Z6** (00-80)  
Cacao **35JO-H6** (00-80)  
Marrón **35JO-26** (00-80)  
Naranja **35JO-N6** (00-80)  
Tango **35JOTA6** (00-80)



# TURKANA 30X30 11<sup>13/16</sup>"X11<sup>13/16</sup>"

 BEIGE III	 BURDEOS III	 AMARILLO IV	 NARANJA IV	 BLANCO IV
 PISTACHO IV	 ANTRACITA III			

Beige **35TK-56** (00-80)  
Burdeos **35TK-26** (00-80)  
Amarillo **35TK-76** (00-80)  
Naranja **35TK-N6** (00-80)  
Blanco **35TK-46** (00-80)  
Pistacho **35TK-P6** (00-80)  
Antracita **35TK-A6** (00-80)

medida cm	nºpzax/box	m²/box	kg/box	boxes/pallet	m²/pallet	kg/pallet
30x30	11	1,00	17,20	64	64,00	1.100,80

# REVESTIMIENTO WALL TILES



CARRELAGE MURAL  
WANDFLIESEN  
RIVESTIMENTO  
PŁYTKI ŚCIENNE  
WANDTEGELS  
ОБЛИЦОВКА СТЕН

## 45X120 17<sup>3/4</sup>" X 47<sup>11/16</sup>"

TEXTURE 188 **N**

## 31,5X100 12<sup>3/8</sup>" X 39<sup>3/8</sup>"

ALSACIA 192  
AUSTIN 196  
BOREAL 200  
CRYSTAL 202  
GALA 204  
KOTA 208  
LANDART 212  
LUXOR 216  
MARITIMA 218 **N**  
MARMÓREA 222 **N**  
REIMS 226  
SARLAT 230 **N**  
VULCANO 100 234  
WABI SABI 100 238 **N**  
WHITE&CO 242 **N**

## 30X90 11<sup>13/16</sup>" X 35<sup>7/16</sup>"

BAHAMAS/VESUBIO 246  
BÁLTICO 248  
BOSTON 252  
CASTILLA 256  
COREA 258  
MONTBLANC 258  
ESTUCO 260  
FUTURA 264  
LORD 266  
NEPAL 270  
PALACE 90 272  
SABLIER 274  
SUECIA/ANTARTIDA 276

## 30X60 11<sup>13/16</sup>" X 23<sup>5/8</sup>"

CHICAGO 278  
COLUMBIA 60 280  
CRETA 284  
EDEN 288  
FINLANDIA/SIBERIA 290  
KOTA 60 292 **N**  
LANDART 60 294 **N**  
LOMBARDIA 296  
MARITIMA 60 300 **N**  
MATERIA 302  
WABI SABI 60 304 **N**

## 25X75 9<sup>7/8</sup>" X 29<sup>9/16</sup>"

JAVA 306  
MISTRAL 308  
SIROCO 310

## 25X40 9<sup>7/8</sup>" X 15<sup>6/8</sup>"

BOSTON 25 314  
CANADA/NEVADA 316  
COLUMBIA 25 318  
REIMS 25 320

## 20X60 7<sup>7/8</sup>" X 23<sup>5/8</sup>"

ATACAMA 322  
NEBRASKA 324

**N**

nuevo · new · nouveau  
neu · nuovo · nowość nieuw  
· новое

TEXTURE 45X120 17<sup>3</sup>/<sub>4</sub>"X47<sup>11</sup>/<sub>16</sub>"



45 x 120 Texture  
Blanco 74TX408 (05-45)



45 x 120 Texture  
Perla 74TX308 (05-45)



45 x 120 Texture  
Beige 74TX708 (05-45)



NUEVO NEW

WALL TILES

REVESTIMIENTO

III Revestimiento: Texture Perla 45 x 120, Spatula Perla 45 x 120, Texture Blanco 45 x 120.

≡ Pavimento: Habana Negro 80 x 80.



10 mm (45x120)

45x120  
≥1,5mm

medida cm	nºpzax/box	m <sup>2</sup> /box	kg/box	boxes/pallet	m <sup>2</sup> /pallet	kg/pallet
45X120	3	1,62	43,32	40	64,80	1.732,80





45 x 120 Onne  
Blanco 74TX428 (05-45)



45 x 120 Onne  
Perla 74TX328 (05-45)



45 x 120 Onne  
Beige 74TX728 (05-45)



45 x 120 Spatula  
Blanco 74TX418 (05-45)



45 x 120 Spatula  
Perla 74TX318 (05-45)



45 x 120 Spatula  
Beige 74TX718 (05-45)



45 x 120 Atelier \*  
74TX938 (05-46)

(\*) 2 gráficas diferentes empaquetadas aleatoriamente en cajas de 3 piezas.  
2 different patterns randomly selected and packed in boxes containing 3 pieces.  
2 verschiedene Grafiken, aleatorisch verpackt mit 4 Stück pro Karton.  
2 graphiques différents, empaquetés par cartons de 3 pièces de façon aléatoire.  
2 pezzi diversi, confezionati casualmente in scatole da 3 pezzi ciascuna.  
2 verschillende patronen, willekeurig geselecteerd en verpakt in dozen van 3 stuks.  
2 różne wzory powierzchni wybierane losowo i zapakowane w pudełkach zawierające 3 sztuk.  
2 различных графических рисунков, упакованных путем случайного выбора по 3 штук в коробке.

medida cm	nºpzax/box	m²/box	kg/box	boxes/pallet	m²/pallet	kg/pallet
45X120	3	1,62	43,32	40	64,80	1.732,80



10 mm (45x120)

45x120

ALSACIA 31,5X100 12<sup>3/8</sup>"X39<sup>3/8</sup>"



# ALSACIA 31,5X100 12<sup>3/8</sup>"X39<sup>3/8</sup>"

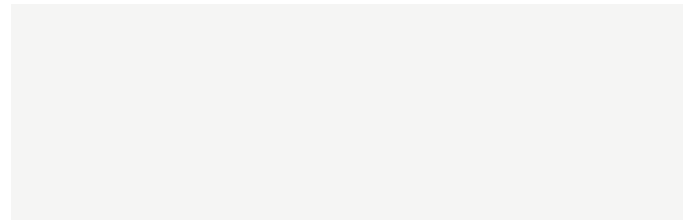

31,5 x 100 Alsacia  
70AL401 (03-85)



31,5 x 100 Basel  
Antracita 70AL601 (05-71)



31,5 x 100 Vosgos  
Blanco 70AL441 (05-73)



31,5 x 100 Vosgos  
Plata 70AL431 (05-73)



31,5 x 100 Nancy\*  
Blanco 70AL411 (05-73)



31,5 x 100 Nancy\*  
Antracita 70AL611 (05-73)



31,5 x 100 Nancy\*  
Blanco 70AL411 (05-73)

# BASEL 60X60 23<sup>5/8</sup>"X23<sup>5/8</sup>"

PORCELÁNICO  
PORCELAIN TILE



60x60 Basel IV  
Antracita 52BA65R (07-83)

[\*] 2 gráficas diferentes empaquetadas aleatoriamente en cajas de 4 piezas.  
2 different patterns randomly selected and packed in boxes containing 4 pieces.  
2 verschiedene Grafiken, aleatorisch verpackt mit 4 Stück pro Karton.  
2 graphiques différents, empaquetés par cartons de 4 pièces de façon aléatoire.  
2 pezzi diversi, confezionati casualmente in scatole da 4 pezzi ciascuna.  
2 verschillende patronen, willekeurig geselecteerd en verpakt in dozen van 4 stuks.  
2 różne wzory powierzchni wybierane losowo i zapakowane w pudełkav zawierające 4 sztuk.  
2 различных графических рисунков, упакованных путем случайного выбора по 4 штук в коробке.



Alsacia



Vosgos  
Nancy  
Basel 60



8,7 mm (31,5X100)  
10 mm (60x60)



R9  
C1  
Basel60x60



31,5x100



60x60



III Revestimiento: Vosgos Blanco 31,5 x 100.



31,5 x 100 Lorena  
17AL93L (20-14)

1,5 x 100 Aluminio 100  
16PR30A (13-65)



30,9 x 31,1 Musa Klimt  
Antracita 69MU-KA (40-60)



26,4 x 27,4 Musa Exagono  
Negro 69MU-EN (40-70)



30 x 30 Musa Fossil  
Antracita 69MU-FA (40-40)



30 x 30 Musa Rectangular  
Negro 69MU-RN (40-40)



30 x 30 Musa Rectangular  
Gris 69MU-RG (40-40)



30 x 30 Musa Rectangular  
Blanco 69MU-RB (40-40)

medida cm	nºpz/box	m²/box	kg/box	boxes/pallet	m²/pallet	kg/pallet
31,5x100	4	1,26	19,50	55	69,30	1.072,50
60x60 pavimento	3	1,08	27,50	32	34,56	880,00

AUSTIN 31,5X100 12<sup>3/8</sup>"X39<sup>3/8</sup>"



# AUSTIN 31,5X100 12<sup>3/8</sup>"X39<sup>3/8</sup>"



31,5 x 100 Austin  
Blanco **70AU401** (05-71)



31,5 x 100 Austin  
Beige **70AU701** (05-71)



31,5 x 100 Austin  
Gris **70AU301** (05-71)



31,5 x 100 Austin  
Antracita **70AU601** (05-71)



31,5 x 100 Travis  
Blanco **17AU43T** (20-14)  
Beige **17AU73T** (20-14)  
Gris **17AU33T** (20-14)  
Antracita **17AU63T** (20-14)



31,5 x 100 Texas  
Beige **70AU711** (06-45)  
Gris **70AU311** (06-45)



31,5 x 100 Cedar  
Beige **17AU73D** (20-14)  
Gris **17AU33D** (20-14)

1,5 x 100 Aluminio 100  
**16PR30A** (13-65)



30,9 x 31,1 Musa Klimt  
Antracita **69MU-KA** (40-60)  
Marrón **69MU-KM** (40-60)



30 x 30 Musa Fossil  
Beige **69MU-FB** (40-40)  
Antracita **69MU-FA** (40-40)

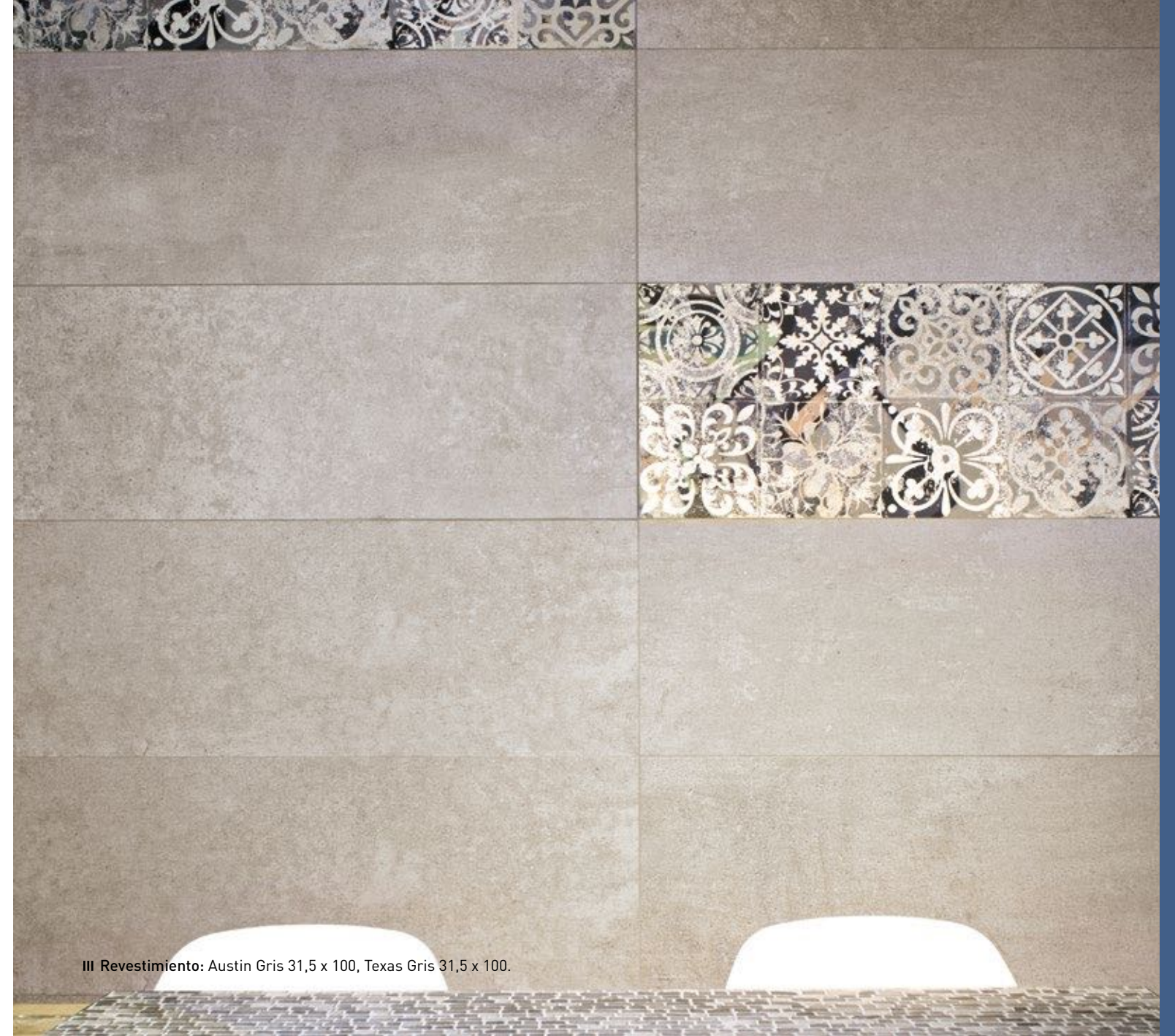

III Revestimiento: Austin Gris 31,5 x 100, Texas Gris 31,5 x 100.

# AUSTIN 60X60 23<sup>5/8</sup>"X23<sup>5/8</sup>"

PORCELÁNICO  
PORCELAIN TILE

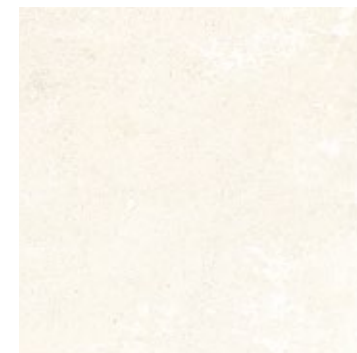

60x60 Austin  
Blanco **52AS45R** (07-83)

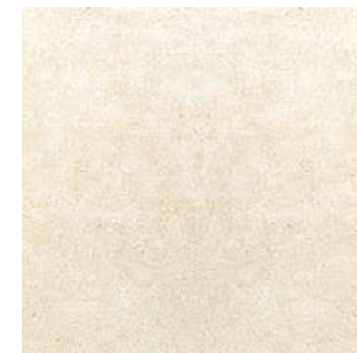

60x60 Austin  
Beige **52AS75R** (07-83)



60x60 Austin  
Gris **52AS35R** (07-83)



60x60 Austin  
Antracita **52AS65R** (07-83)

Rodapié  
10x60 (11-75)

medida cm	nºpzax/box	m <sup>2</sup> /box	kg/box	boxes/pallet	m <sup>2</sup> /pallet	kg/pallet
31,5x100	4	1,26	19,50	55	69,30	1.072,50
60x60 pavimento	3	1,08	27,50	32	34,56	880,00

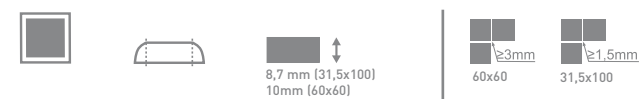

8,7 mm (31,5x100)  
10mm (60x60)

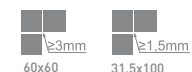

3mm  
60x60  
1,5mm  
31,5x100

**BOREAL** 31,5X100 12<sup>3/8</sup>"X39<sup>3/8</sup>"

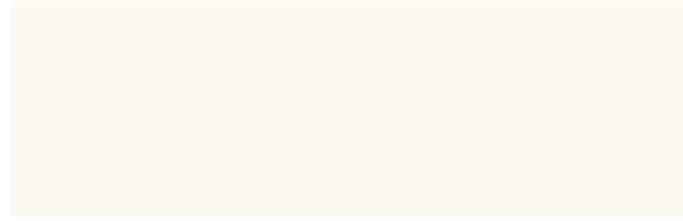

31,5 x 100 Boreal  
Blanco **70B0401** (03-85)

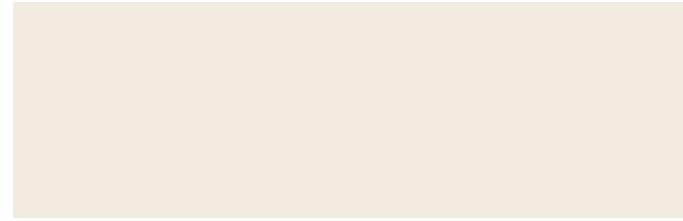

31,5 x 100 Boreal  
Beige **70B0701** (03-85)



31,5 x 100 Lorena  
**17AL93L** (20-14)



31,5 x 100 Narval  
**70B0431** (05-73)

1,5 x 100 Aluminio 100  
**16PR30A** (13-65)



30,9 x 31,1 Musa Klimt  
Antracita **69MU-KA** (40-60)



30 x 30 Musa Fossil  
Antracita **69MU-FA** (40-40)

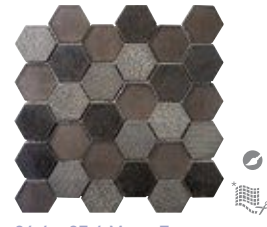

26,4 x 27,4 Musa Exagono  
Negro **69MU-EN** (40-70)



30 x 30 Musa Rectangular  
Negro **69MU-RN** (40-40)

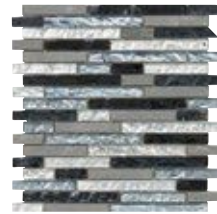

30 x 30 Musa Rectangular  
Gris **69MU-RG** (40-40)



30 x 30 Musa Rectangular  
Blanco **69MU-RB** (40-40)

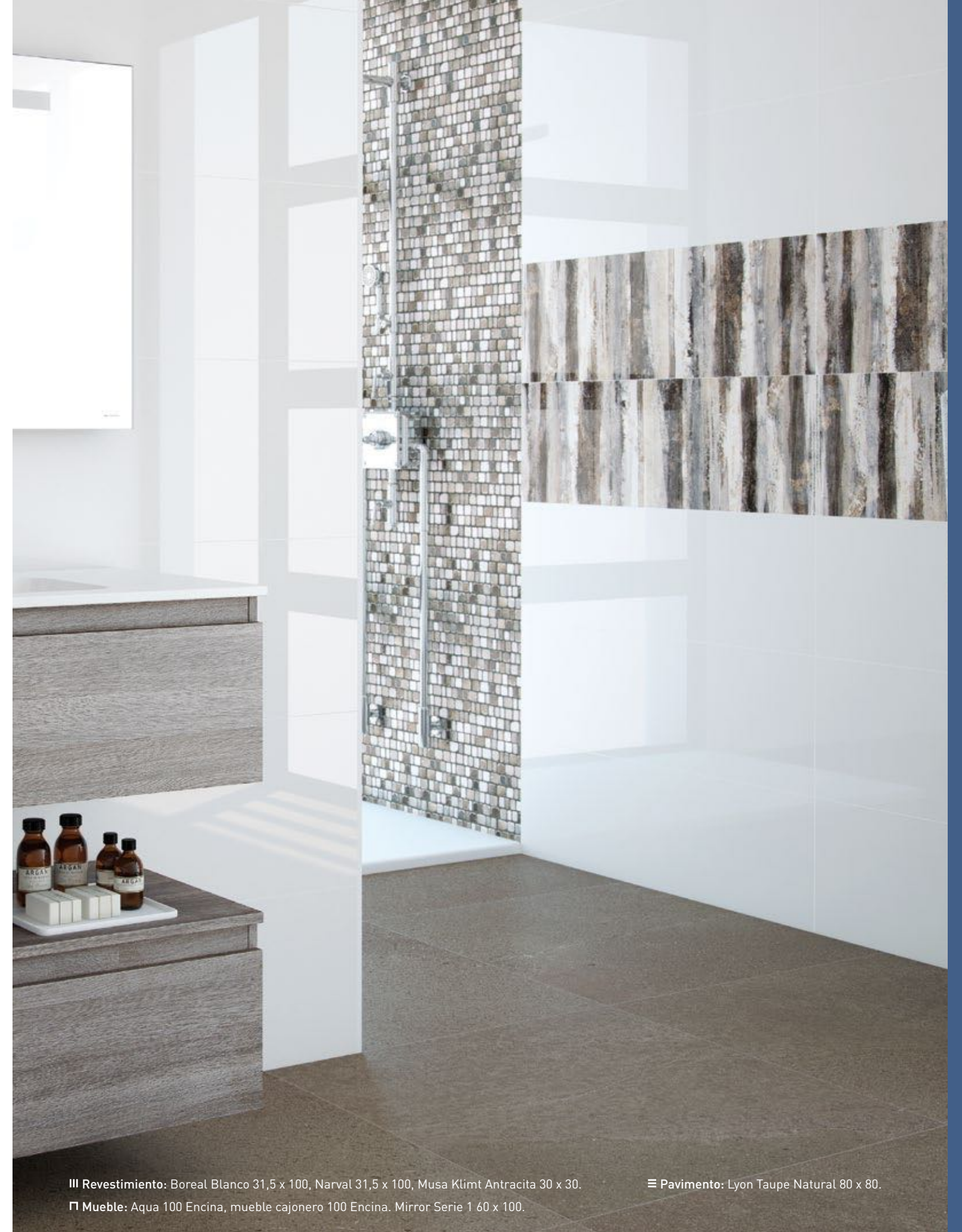

III Revestimiento: Boreal Blanco 31,5 x 100, Narval 31,5 x 100, Musa Klimt Antracita 30 x 30.

≡ Pavimento: Lyon Taupe Natural 80 x 80.

Π Mueble: Aqua 100 Encina, mueble cajonero 100 Encina. Mirrор Serie 1 60 x 100.

medida cm	nºpzax/box	m²/box	kg/box	boxes/pallet	m²/pallet	kg/pallet
31,5x100	4	1,26	19,50	55	69,30	1.072,50



CRYSTAL 31,5X100 12<sup>3/8</sup>"X39<sup>3/8</sup>"



31,5 x 100 Crystal  
Blanco **70CR401** (05-71)



31,5 x 100 Crystal  
Gris **70CR301** (05-71)



1,5 x 100 Aluminio 100  
**16PR30A** (13-65)



31,5 x 100 Merlin  
Blanco **17CR43M** (18-00)



31,5 x 100 Merlin  
Gris **17CR33M** (18-00)



31,5 x 100 Pandora  
Blanco **70CR411** (06-45)



31,5 x 100 Pandora  
Gris **70CR311** (06-45)

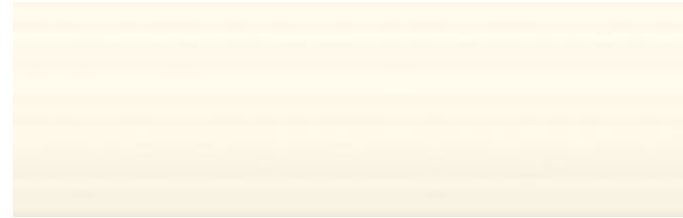

31,5 x 100 Crystal  
Marfil **70CR701** (05-71)



31,5 x 100 Crystal  
Marino **70CR601** (05-71)



31,5 x 100 Merlin  
Marfil **17CR73M** (18-00)

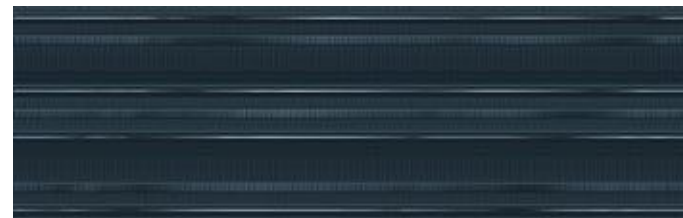

31,5 x 100 Merlin  
Marino **17CR63M** (18-00)

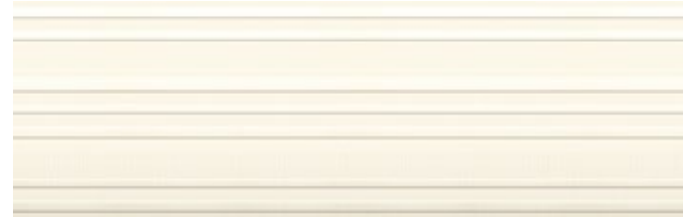

31,5 x 100 Pandora  
Marfil **70CR711** (06-45)

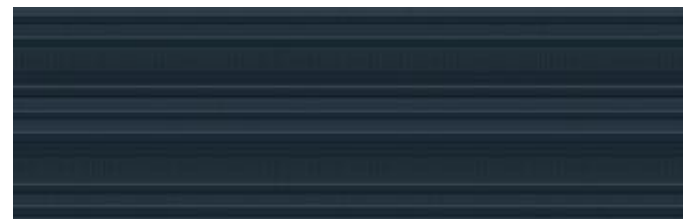

31,5 x 100 Pandora  
Marino **70CR611** (06-45)



III Revestimiento: Crystal Blanco y Marino 31,5 x 100, Merlin Blanco y Marino 31,5 x 100, Pandora Blanco y Marino 31,5 x 100.  
≡ Pavimento: Titan Cemento 60 x 60.  
Π Mueble: Aster 60 Blanco (2 unidades), Mirror Serie 3 60 x 120.

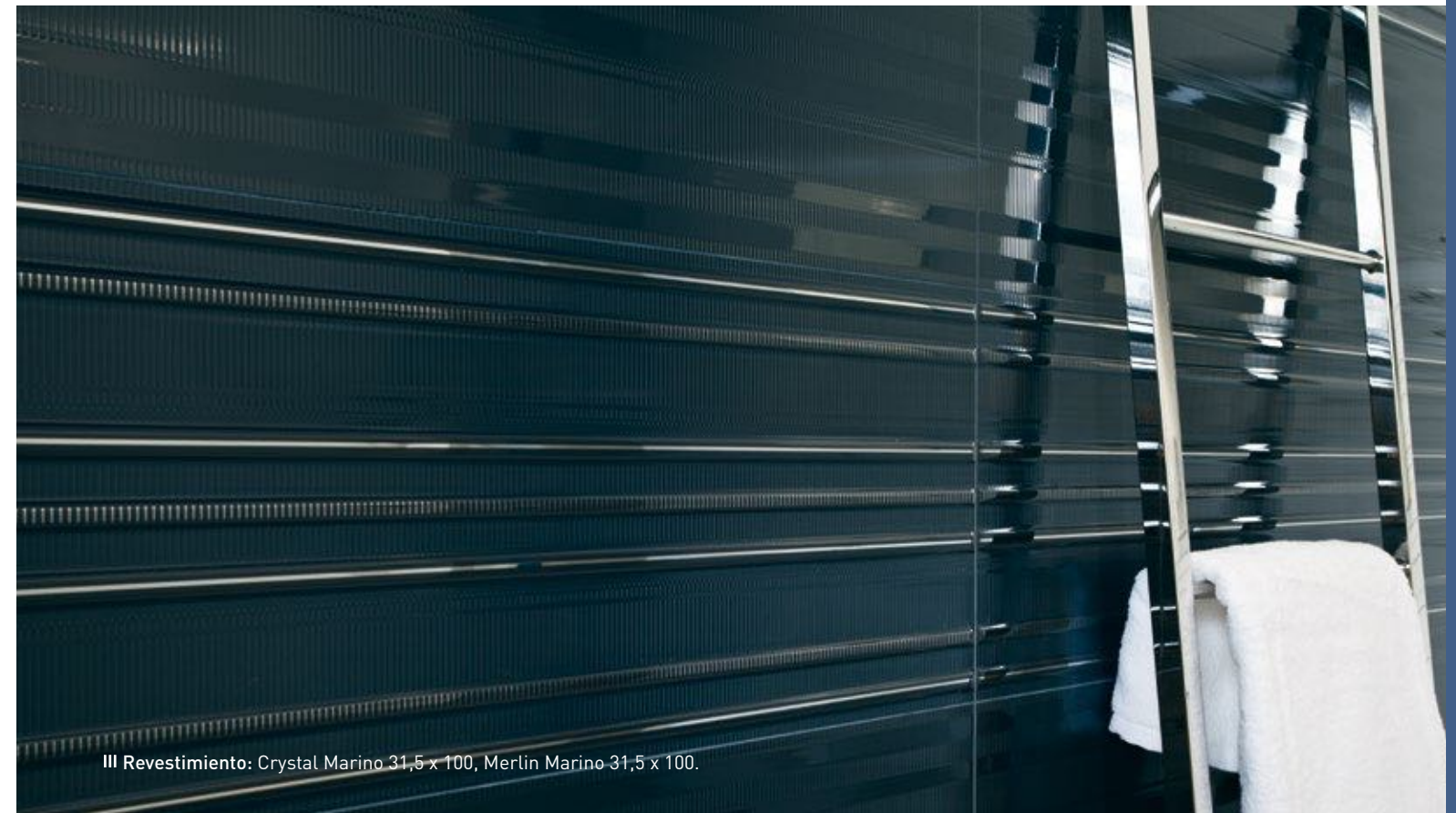

III Revestimiento: Crystal Marino 31,5 x 100, Merlin Marino 31,5 x 100.

medida cm	nºpzax/box	m²/box	kg/box	boxes/pallet	m²/pallet	kg/pallet
31,5x100	4	1,26	19,50	55	69,30	1.072,50



**GALA** 31,5X100 12<sup>3/8</sup>"X39<sup>3/8</sup>"

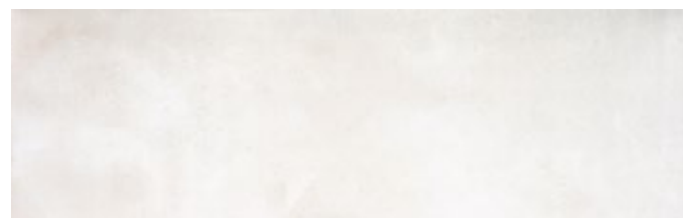

31,5 x 100 Gala  
Blanco **70GA401** (05-71)



31,5 x 100 Gala  
Cielo **70GA501** (05-71)



31,5 x 100 Gala  
Marino **70GA601** (05-71)



31,5 x 100 Gala  
Gris **70GA301** (05-71)



31,5 x 100 Gala  
Arena **70GA701** (05-71)



31,5 x 100 Gala  
Make up **70GA101** (05-71)



31,5 x 100 Cintia  
Blanco **70GA411** (05-71)



31,5 x 100 Cintia  
Cielo **70GA511** (05-71)

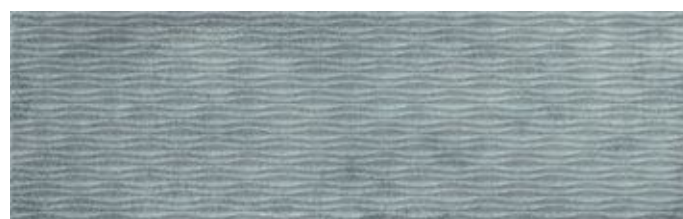

31,5 x 100 Cintia  
Marino **70GA611** (05-71)

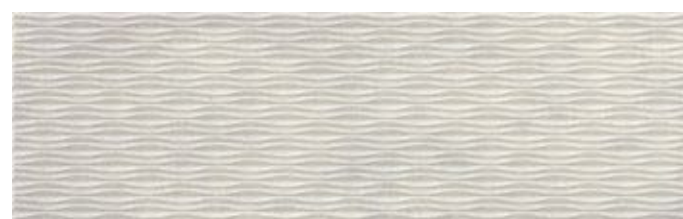

31,5 x 100 Cintia  
Gris **70GA311** (05-71)



31,5 x 100 Cintia  
Arena **70GA711** (05-71)



31,5 x 100 Cintia  
Make up **70GA111** (05-71)



31,5 x 100 Elisa  
Blanco **17GA43S** (13-95)



31,5 x 100 Elisa  
Cielo **17GA53S** (13-95)



31,5 x 100 Elisa  
Marino **17GA63S** (13-95)



31,5 x 100 Elisa  
Gris **17GA33S** (13-95)



31,5 x 100 Elisa  
Arena **17GA73S** (13-95)



31,5 x 100 Elisa  
Make up **17GA13S** (13-95)



1,5 x 100 Selene  
Antracita **16GA60S** (12-81)



1,5 x 100 Selene  
Acero **16GA30S** (12-81)



1,5 x 100 Selene  
Bronce **16GA90S** (12-81)



1,5 x 100 Selene  
Plomo **16GA50S** (12-81)

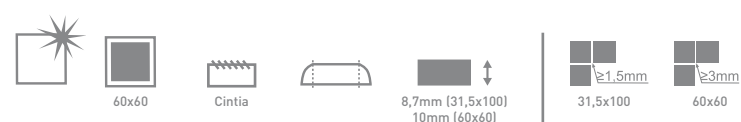

medida cm	nºpzax/box	m²/box	kg/box	boxes/pallet	m²/pallet	kg/pallet
31,5x100	4	1,26	19,50	55	69,30	1072,50
60x60 pavimento	3	1,08	27,50	32	34,56	880,00



**GALA 31,5X100 12<sup>3/8</sup>"X39<sup>3/8</sup>"**



31,5 x 100 Penelope  
Blanco 70GA431 (06-45)



31,5 x 100 Sofia  
Blanco 70GA421 (06-45)



31,5 x 100 Penelope  
Beige 70GA731 (06-45)



31,5 x 100 Sofia  
Beige 70GA721 (06-45)



31,5 x 100 Marianne\*  
70GA441 (06-45)

(\* 3 gráficas diferentes empaquetadas aleatoriamente en cajas de 4 piezas.  
3 different patterns randomly selected and packed in boxes containing 4 pieces.  
3 verschiedene Grafiken, aleatorisch verpackt mit 4 Stück pro Karton.  
3 graphiques différents, empaquetés par cartons de 4 pièces de façon aléatoire.  
3 pezzi diversi, confezionati casualmente in scatole da 4 pezzi cadauna.  
3 verschillende patronen, willekeurig geselecteerd en verpakt in dozen van 4 stuks  
3 różnych wzorów powierzchni wybieranych losowo i zapakowane w pudełkach zawierające 4 sztuk.  
3 различных графических рисунков, упакованных путем случайного выбора по 4 штук в коробке.



III Revestimiento: Gala Gris 31,5x100, Elisa Gris 31,5x100, Selene Acero 1,5x100  
II Mueble: Aqua 120 Seno izquierdo Antracita, mueble cajonero 60 Antracita.

III Pavimento: Gala Gris 60 x 60.

**GALA 60X60 23<sup>5/8</sup>"X23<sup>5/8</sup>"**



60x60 Gala  
Blanco 52GA45R (07-83)

IV



60x60 Gala  
Cielo 52GA55R (07-83)

IV



60x60 Gala  
Marino 52GA65R (07-83)

IV



60x60 Gala  
Gris 52GA35R (07-83)

IV



60x60 Gala  
Arena 52GA75R (07-83)

IV



60x60 Gala  
Make up 52GA15R (07-83)

IV

PORCELÁNICO  
PORCELAIN TILE

medida cm	nºpzax/box	m²/box	kg/box	boxes/pallet	m²/pallet	kg/pallet
31,5x100	4	1,26	19,50	55	69,30	1072,50
60x60 pavimento	3	1,08	27,50	32	34,56	880,00

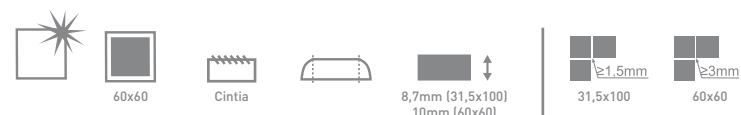

KOTA 31,5X100 12<sup>3/8</sup>" X39<sup>3/8</sup>"



III Revestimiento: Kota Gris 31,5 x 100, Ado Gris 31,5 x 100  
≡ Pavimento: Gea Perla 80 x 80

▣ Mueble: Coverlam Titan Cemento

KOTA 31,5X100 12<sup>3/8</sup>"X39<sup>3/8</sup>"



31,5 x 100 Kota  
Blanco **70K0401** (05-71)



31,5 x 100 Kota  
Gris **70K0301** (05-71)



31,5 x 100 Ado  
Blanco **70K0411** (05-71)



31,5 x 100 Ado  
Gris **70K0311** (05-71)



31,5 x 100 Theo\*  
Blanco **70K0431** (06-45)



31,5 x 100 Theo\*  
Gris **70K0331** (06-45)



31,5 x 100 Kota  
Beige **70K0701** (05-71)



31,5 x 100 Kota  
Negro **70K0901** (05-71)



31,5 x 100 Ado  
Beige **70K0711** (05-71)



31,5 x 100 Ado  
Negro **70K0911** (05-71)



31,5 x 100 Theo\*  
Beige **70K0731** (06-45)



31,5 x 100 Theo\*  
Negro **70K0931** (06-45)

**COMBINA CON EL PAVIMENTO**  
MATCHES FLOOR TILES  
ASSORTIS AUX CARREAUX DE SOL  
PASST ZU DEN BODENFLIESEN  
SI ABBINA AL PAVIMENTO  
PROPONOWANE POŁĄCZENIE Z PŁYTKĄ PODŁOGOWĄ  
СОЧЕТАЕТСЯ С НАПОЛЬНОМ ПОКРЫТИЕМ

ESCORIAL  
60X60 / 80X80

PÁG. 116

[\*] 4 gráficas diferentes empaquetadas aleatoriamente en cajas de 4 piezas.  
4 different patterns randomly selected and packed in boxes containing 4 pieces.  
4 verschiedene Grafiken, aleatorisch verpackt mit 4 Stück pro Karton.  
4 graphiques différents, empaquetés par cartons de 4 pièces de façon aléatoire.  
4 pezzi diversi, confezionati casualmente in scatole da 4 pezzi ciascuna.  
4 verschillende patronen, willekeurig geselecteerd en verpakt in dozen van 4 stuks.  
4 różne wzory powierzchni wybierane losowo i zapakowane w pudełka zawierające 4 sztuk.  
4 различных графических рисунков, упакованных путем случайного выбора по 4 штук в коробке.



III Revestimiento: Kota Negro 31,5 x 100, Yan Negro 31,5 x 100, Kota Blanco 31,5 x 100.  
Pavimento: Cambridge Coffe 29,5x120 / 14,5x120.



31,5 x 100 Yan  
Blanco **70K0421** (05-71)



31,5 x 100 Yan  
Gris **70K0321** (05-71)



31,5 x 100 Yan  
Beige **70K0721** (05-71)

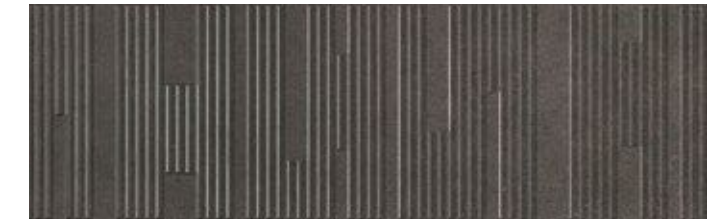

31,5 x 100 Yan  
Negro **70K0921** (05-71)

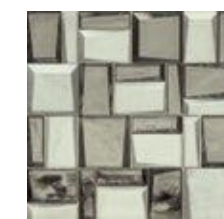

30 x 30 Musa Cristal Plata  
**69MU-CP** (40-75)



30 x 30 Musa Cristal Oro  
**69MU-CR** (40-75)



1,5 x 100 Selene  
Antracita **16GA60S** (12-81)



1,5 x 100 Selene  
Acero **16GA30S** (12-81)



1,5 x 100 Selene  
Bronce **16GA90S** (12-81)



1,5 x 100 Selene  
Plomo **16GA50S** (12-81)

medida cm	nºpzax/box	m <sup>2</sup> /box	kg/box	boxes/pallet	m <sup>2</sup> /pallet	kg/pallet
31,5x100	4	1,26	19,50	55	69,30	1.072,50

LANDART 31,5X100 12<sup>3/8</sup>"X39<sup>3/8</sup>"



III Revestimiento: Landart Beige 31,5 x 100, Grid Beige 31,5 x 100 / Landart Taupé 31,5 x 100, Walter Beige 31,5 x 100.  
≡ Pavimento: Gea Taupé 60 x 60.  
□ Mueble: Aqua 120 Seno Izquierdo Blanco, Mueble cajonero 60 Blanco.

# LANDART 31,5X100 12<sup>3/8</sup>"X39<sup>3/8</sup>"



31,5 x 100 Landart  
Blanco 70LD401 (05-71)



31,5 x 100 Landart  
Gris 70LD301 (05-71)



31,5 x 100 Grid  
Blanco 70LD421 (05-71)

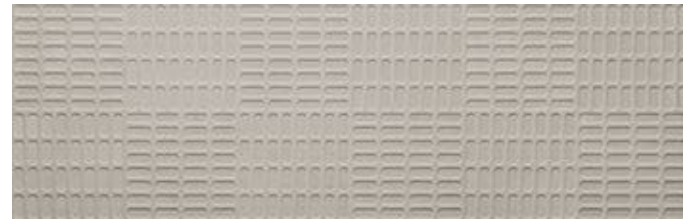

31,5 x 100 Grid  
Gris 70LD321 (05-71)



31,5 x 100 Basket  
Blanco 70LD411 (05-71)



31,5 x 100 Basket  
Gris 70LD311 (05-71)



31,5 x 100 Landart  
Beige 70LD701 (05-71)



31,5 x 100 Landart  
Taupé 70LD201 (05-71)



31,5 x 100 Grid  
Beige 70LD721 (05-71)



31,5 x 100 Grid  
Taupé 70LD221 (05-71)



31,5 x 100 Basket  
Beige 70LD711 (05-71)



31,5 x 100 Basket  
Taupé 70LD211 (05-71)



III Revestimiento: Landart Blanco 31,5 x 100, Basquet Blanco 31,5 x 100 / Landart Gris 31,5 x 100.  
≡ Pavimento: Gea Blanco 80 x 80.



31,5 x 100 Walter\*  
Blanco 70LD431 (06-45)



31,5 x 100 Walter\*  
Beige 70LD731 (06-45)



30 x 30 Musa Cristal Oro  
69MU-CR (40-75)

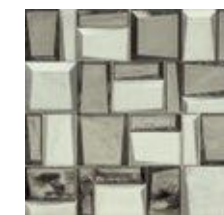

30 x 30 Musa Cristal Plata  
69MU-CP (40-75)

(\*) 3 gráficas diferentes empaquetadas aleatoriamente en cajas de 4 piezas.  
3 different patterns randomly selected and packed in boxes containing 4 pieces.  
3 verschiedene Grafiken, aleatorisch verpackt mit 4 Stück pro Karton.  
3 graphiques différents, empaquetés par cartons de 4 pièces de façon aléatoire.  
3 pezzi diversi, confezionati casualmente in scatole da 4 pezzi ciascuna.  
3 verschillende patronen, willekeurig geselecteerd en verpakt in dozen van 4 stuks.  
3 różne wzory powierzchni wybierane losowo i zapakowane w pudełka zawierające 4 sztuk.  
3 различных графических рисунков, упакованных путем случайного выбора по 4 штук в коробке.

1,5 x 100 Selene  
Antracita 166A605 (12-81)

1,5 x 100 Selene  
Acero 166A305 (12-81)

1,5 x 100 Selene  
Bronce 166A905 (12-81)

1,5 x 100 Selene  
Plomo 166A505 (12-81)

COMBINA CON EL PAVIMENTO  
MATCHES FLOOR TILES  
ASSORTIS AUX CARREAUX DE SOL  
PASST ZU DEN BODENFLIESEN  
SI ABBINA AL PAVIMENTO  
PROPONOWANE POŁĄCZENIE Z PŁYTKĄ PODŁOGOWĄ  
СОЧЕТАЕТСЯ С НАПОЛЬНЫМ ПОКРЫТИЕМ

GEA  
60X60 / 60X120 / 80X80

PÁG. 128

medida cm	nºpzas/box	m²/box	kg/box	boxes/pallet	m²/pallet	kg/pallet
31,5x100	4	1,26	19,50	55	69,30	1072,50



# LUXOR 31,5X100 12<sup>3/8</sup>"X39<sup>3/8</sup>"



31,5 x 100 Luxor Onda  
Blanco **70LX040** (94-50)



31,5 x 100 Luxor Onda  
Beige **70LX070** (94-50)



31,5 x 100 Luxor Área  
Blanco **70LXA40** (94-50)



31,5 x 100 Luxor Área  
Beige **70LXA70** (94-50)



31,5 x 100 Luxor Figura  
Blanco **70LXF40** (94-50)

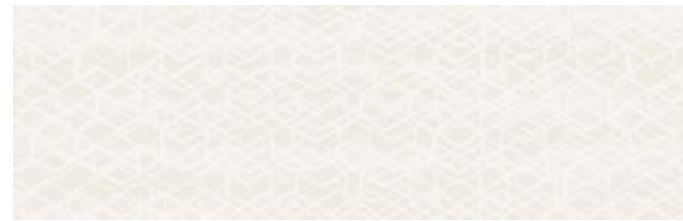

31,5 x 100 Luxor Figura  
Beige **70LXF70** (94-50)



31,5 x 100 Luxor Lineal  
Blanco **70LXL40** (94-50)



31,5 x 100 Luxor Lineal  
Beige **70LXL70** (94-50)



31,5 x 100 Luxor Código  
Blanco **70LXC40** (94-50)



31,5 x 100 Luxor Código  
Beige **70LXC70** (94-50)

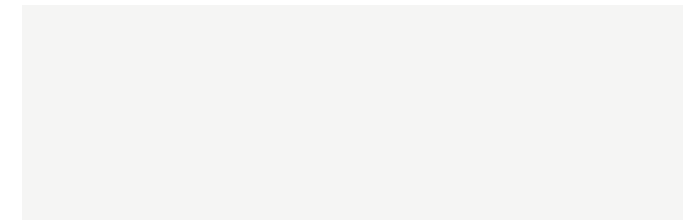

31,5 x 100 Alsacia  
Blanco **70AL401** (03-85)

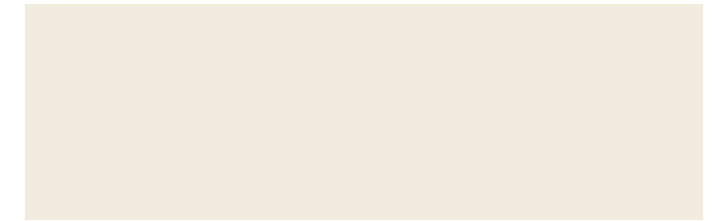

31,5 x 100 Boreal  
Beige **70B0701** (03-85)



III Revestimiento: Luxor Figura Blanco 31,5 x 100, Austin Antracita 31,5 x 100.  
 ≡ Pavimento: Austin Antracita 60 x 60.  
 Π Mueble: Aqua 120 doble Seno Blanco, mueble cajonero 60 Blanco. Mirror Serie 5 60 x 120.

## COMBINA CON EL REVESTIMIENTO

MATCHES WALL TILES  
 ASSOCIER AVEC LE CARRELAGE MURAL  
 PASSEZ A LA DER WANDFLIESE  
 ABBINA CON IL RIVESTIMENTO  
 PROPONOWANE POŁĄCZENIE Z PŁYTKĄ ŚCIENNĄ  
 СОЧЕТАЕТСЯ С НАСТЕННОЙ ПЛИТКОЙ

## 31,5 X 100

AUSTIN PÁG. 196  
 BASEL PÁG. 194  
 GALA PÁG. 204  
 KOTA PÁG. 208  
 LANDART PÁG. 212  
 REIMS PÁG. 216  
 SARLAT PÁG. 230  
 VULCANO100 PÁG. 234

## COMBINA CON EL PAVIMENTO

MATCHES FLOOR TILES  
 ASSORTIS AUX CARREAUX DE SOL  
 PASST ZU DEN BODENFLIESEN  
 SI ABBINA AL PAVIMENTO  
 PROPONOWANE POŁĄCZENIE Z PŁYTKĄ PODŁOGOWĄ  
 СОЧЕТАЕТСЯ С НАПОЛЬНОМ ПОКРЫТИЕМ

## MULTIFORMATO

ALPES PÁG. 030  
 AVALON PÁG. 074  
 AVENUE PÁG. 078  
 BOSTON PÁG. 088  
 GEA PÁG. 118  
 LYON PÁG. 040

medida cm	nºpzas/box	m²/box	kg/box	boxes/pallet	m²/pallet	kg/pallet
31,5x100	4	1,26	19,50	55	69,30	1072,50





III Revestimiento: Barents blanco 31,5 x 100, kara 31,5 x 100.  
≡ Pavimento: Sherwood Roble 14,5 x 120.  
□ Mueble: Aqua 100 Blanco.



31,5 x 100 Báltico  
Blanco 70BT401 (05-71)



31,5 x 100 Egeo 100  
Blanco 70EE401 (05-71)



31,5 x 100 Barents 100  
Blanco 70BR401 (05-71)



31,5 x 100 Barents 100  
Beige 70BR701 (05-71)



31,5 x 100 Balear  
Blanco 70BT421 (05-73)



31,5 x 100 Balear  
Plata 70BT921 (05-73)



31,5 x 100 Alboran  
70BT911 (05-73)



31,5 x 100 Lorena  
17AL93L (20-14)



31,5 x 100 Labrador  
70BT411 (05-73)

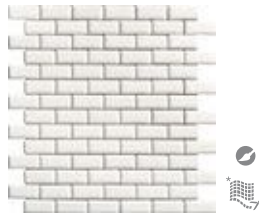

30 x 30 Tallin  
Blanco 69TL-BL (40-40)



30 x 30 Tallin  
Arena 69TL-AR (40-40)



31,5 x 100 Kara (set de 3 piezas)  
17BT93K (20-05)



31,5 x 100 Grumant (set de 3 piezas)  
17BT93G (20-05)



1,5 x 100 Aluminio 100  
16PR30A (13-65)

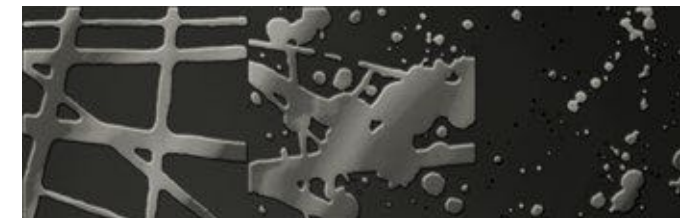

0,5 x 100 Steel  
16SL30S (12-70)

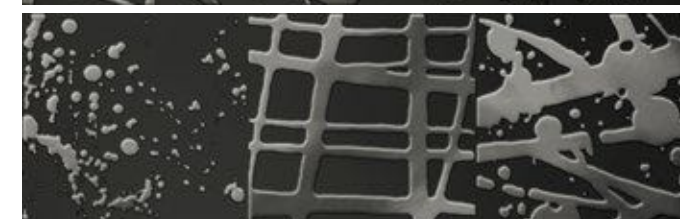

1,5 x 100 Selene  
Antracita 16GA60S (12-81)

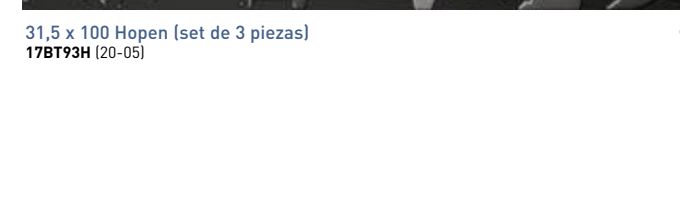

1,5 x 100 Selene  
Acero 16GA30S (12-81)



1,5 x 100 Selene  
Bronce 16GA90S (12-81)

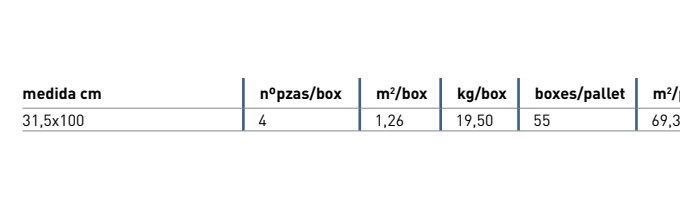

1,5 x 100 Selene  
Plomo 16GA50S (12-81)



16x60 Valle  
Blanco 08VA-44 (13-05)  
Grafito 08VA-64 (13-05)  
Negro 08VA-94 (13-05)



30x30 Cima  
Blanco 41AP40C (09-05)  
Grafito 41AP60C (09-05)  
Negro 41AP90C (09-05)

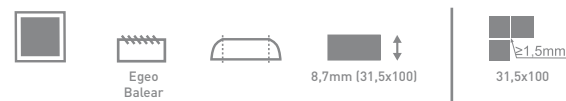

medida cm	nºpz/box	m²/box	kg/box	boxes/pallet	m²/pallet	kg/pallet
31,5x100	4	1,26	19,50	55	69,30	1072,50





III Revestimiento: Marmórea Calacata 31,5 x 100, Marmórea Paladio 31,5 x 100, Ábaco Paladio 31,5 x 100.  
≡ Pavimento: Calacata 60 x 60.



31,5 x 100 Marmorea  
Calacata **70MD401** (05-71)



31,5 x 100 Abaco  
Calacata **70MD411** (05-73)



31,5 x 100 Danby  
Calacata **17MD43C** (20-14)



31,5 x 100 Celosia  
Calacata **70MD421** (05-73)



31,5 x 100 Marmorea  
Paladio **70MD201** (05-71)



31,5 x 100 Abaco  
Paladio **7MD211** (05-73)

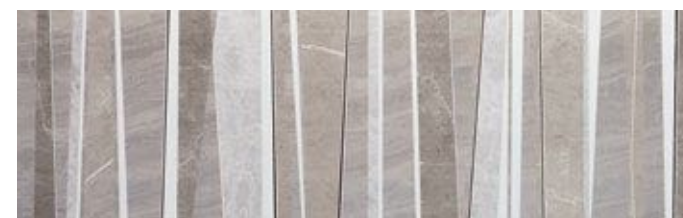

31,5 x 100 Danby  
Paladio **17MD23P** (20-14)

COMBINA CON EL PAVIMENTO

MATCHES FLOOR TILES  
ASSORTIS AUX CARREAUX DE SOL  
PASST ZU DEN BODENFLIESEN  
SI ABBINA AL PAVIMENTO  
PROPONOWANE POŁĄCZENIE Z PŁYTKĄ PODŁOGOWĄ  
СОЧЕТАЕТСЯ С НАПОЛЬНЫМ ПОКРЫТИЕМ

CALACATA  
60X120 / 60X60 / 30X60 /  
30X30

PÁG. 094



30 x 30 Hexagonal  
Calacata **69HE-CA** (40-40)



30 x 30 Hexagonal  
Paladio **69HE-PA** (40-40)

0,5 x 100 Steel  
**16SL30S** (12-70)

1,5 x 100 Selene  
Antracita **16GA60S** (12-81)

1,5 x 100 Selene  
Acero **16GA30S** (12-81)

1,5 x 100 Selene  
Bronce **16GA90S** (12-81)

1,5 x 100 Selene  
Plomo **16GA50S** (12-81)

medida cm	nºpzax/box	m <sup>2</sup> /box	kg/box	boxes/pallet	m <sup>2</sup> /pallet	kg/pallet
31,5x100	4	1,26	19,50	55	69,30	1072,50



REIMS 31,5X100 12<sup>3/8</sup>"X39<sup>3/8</sup>"



III Revestimiento: Reims Gris 31,5 x 100, Narbonne Gris 31,5 x 100.  
≡ Pavimento: Sherwood Haya 19,5 x 100.

# REIMS 31,5X100 12<sup>3/8</sup>"X39<sup>3/8</sup>"



31,5 x 100 Reims  
Blanco **70RE401** (05-71)



31,5 x 100 Nimes  
Blanco **70RE441** (05-71)



31,5 x 100 Narbonne  
Blanco **70RE431** (06-45)



15,7 x 100 Amiens  
Blanco **16RE40A** (20-00)



31,5 x 100 Reims  
Marfil **70RE701** (05-71)



31,5 x 100 Nimes  
Marfil **70RE741** (05-71)



31,5 x 100 Narbonne  
Marfil **70RE731** (06-45)



15,7 x 100 Amiens  
Marfil **16RE70A** (20-00)



31,5 x 100 Reims  
Gris **70RE301** (05-71)



31,5 x 100 Nimes  
Gris **70RE341** (05-71)



31,5 x 100 Narbonne  
Gris **70RE331** (06-45)



15,7 x 100 Amiens  
Gris **16RE30A** (20-00)



31,5 x 100 Beziers  
Blanco **70RE411** (05-71)



31,5 x 100 Jacquard  
Blanco **70RE421** (05-71)



31,5 x 100 Robine  
**17RE03R** (20-13)



1,5 x 100 Selene  
Antracita **16GA60S** (12-81)



1,5 x 100 Selene  
Acero **16GA30S** (12-81)



31,5 x 100 Beziers  
Marfil **70RE711** (05-71)



31,5 x 100 Jacquard  
Marfil **70RE721** (05-71)



31,5 x 100 Chartres  
**17RE03C** (20-13)

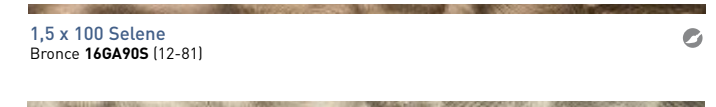

1,5 x 100 Selene  
Bronce **16GA90S** (12-81)



1,5 x 100 Selene  
Plomo **16GA50S** (12-81)



31,5 x 100 Beziers  
Gris **70RE311** (05-71)

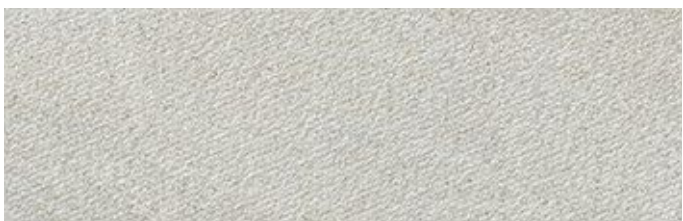

31,5 x 100 Jacquard  
Gris **70RE321** (05-71)



30 x 30 Musa Rectangular  
Marrón **69MU-RM** (40-40)

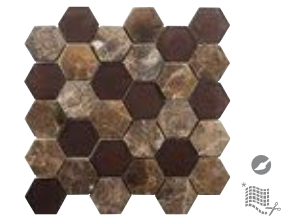

26,4 x 27,4 Musa Exagono  
Marrón **69MU-EM** (40-70)



26,4 x 27,4 Musa Exagono  
Negro **69MU-EN** (40-70)

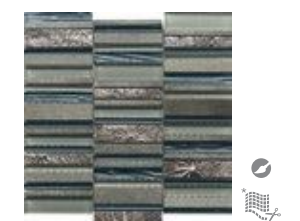

30 x 30 Musa Fossil  
Antracita **69MU-FA** (40-40)

COMBINA CON EL PAVIMENTO  
MATCHES FLOOR TILES  
ASSORTIS AUX CARREAUX DE SOL  
PASST ZU DEN BODENFLIESEN  
SI ABBINA AL PAVIMENTO  
PROPONOWANE POŁĄCZENIE Z PŁYTKĄ PODŁOGOWĄ  
СОЧЕТАЕТСЯ С НАПОЛЬНОМ ПОКРЫТИЕМ

SHERWOOD PÁG 162  
LYON PÁG.040  
Lyon Gris-Reims Blanco  
Lyon Taupé- Reims Marfil  
Lyon Galena- Reims Gris  
REIMS 30X30 PÁG.320

medida cm	nºpzax/box	m²/box	kg/box	boxes/pallet	m²/pallet	kg/pallet
31,5x100	4	1,26	19,50	55	69,30	1072,50
60x60 pavimento	3	1,08	27,50	32	34,56	880,00

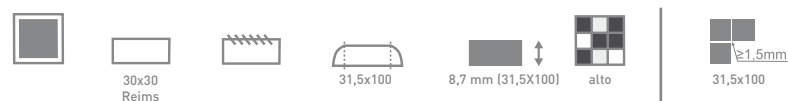

SARLAT 31,5X100 12<sup>3</sup>/<sub>8</sub>" X39<sup>3</sup>/<sub>8</sub>"

NUEVO NEW



III Revestimiento: Sarlat Gris 31,5 x 100, Magister Gris 31,5 x 100, Gradina Gris 31,5 x 100.  
≡ Pavimento: Escorial Blanco Natural 60 x 60.



31,5 x 100 Sarlat  
Blanco **70SR401** (05-71)



31,5 x 100 Gradina  
Blanco **70SR421** (05-71)



31,5 x 100 Magister  
Blanco **70SR431** (05-73)



31,5 x 100 Logia  
Blanco **70SR411** (05-73)



31,5 x 100 Sarlat  
Beige **70SR701** (05-71)



31,5 x 100 Gradina  
Beige **70SR721** (05-71)



31,5 x 100 Magister  
Beige **70SR731** (05-73)



31,5 x 100 Logia  
Beige **70SR711** (05-73)



31,5 x 100 Sarlat  
Gris **70SR301** (05-71)



31,5 x 100 Gradina  
Gris **70SR321** (05-71)



31,5 x 100 Magister  
Gris **70SR331** (05-73)



31,5 x 100 Logia  
Gris **70SR311** (05-73)

0,5 x 100 Steel  
**16SL305** (12-70)

1,5 x 100 Selene  
Antracita **16GA605** (12-81)

1,5 x 100 Selene  
Acero **16GA305** (12-81)

1,5 x 100 Selene  
Bronce **16GA905** (12-81)

1,5 x 100 Selene  
Plomo **16GA505** (12-81)



medida cm	nºpzax/box	m²/box	kg/box	boxes/pallet	m²/pallet	kg/pallet
31,5x100	4	1,26	19,50	55	69,30	1072,50

VULCANO 100 31,5X100 12<sup>3/8</sup>"X39<sup>3/8</sup>"



III Revestimiento: Vulcano 100 Blanco 31,5 x 100 / Corten 31,5 x 100, Golden Gate 31,5 x 100.  
III Pavimento: Vulcano Iron Natural 80 x 80.

# VULCANO 100 31,5X100 12<sup>3/8</sup>"X39<sup>3/8</sup>"



31,5 x 100 Vulcano 100  
Blanco **70VL401** (05-71)



31,5 x 100 Vulcano 100  
Silver **70VL301** (05-71)



31,5 x 100 Santa Justa  
Blanco **70VL411** (05-71)



31,5 x 100 Santa Justa  
Silver **70VL311** (05-71)

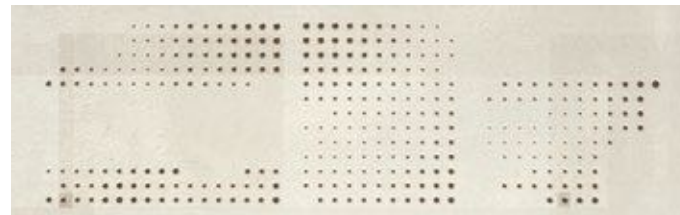

31,5 x 100 Milenio  
Blanco **70VL421** (05-71)



31,5 x 100 Milenio  
Silver **70VL321** (05-71)



31,5 x 100 Vulcano 100  
Corten **70VL201** (05-71)



31,5 x 100 Vulcano 100  
Iron **70VL901** (05-71)



31,5 x 100 Santa Justa  
Corten **70VL211** (05-71)



31,5 x 100 Santa Justa  
Iron **70VL911** (05-71)



31,5 x 100 Milenio  
Corten **70VL221** (05-71)



31,5 x 100 Milenio  
Iron **70VL921** (05-71)



III Revestimiento: Vulcano 100 Silver 31,5 x 100 / Iron 31,5 x 100, Milenio Silver 31,5 x 100.  
III Pavimento: Gea Cemento 80 x 80.



31,5 x 100 Golden Gate\*  
**70VL031** (06-45)

[\*] 3 gráficas diferentes empaquetadas aleatoriamente en cajas de 4 piezas.  
3 different patterns randomly selected and packed in boxes containing 4 pieces.  
3 verschiedene Grafiken, aleatorisch verpackt mit 4 Stück pro Karton.  
3 graphiques différents, empaquetés par cartons de 4 pièces de façon aléatoire.  
3 pezzi diversi, confezionati casualmente in scatole da 4 pezzi ciascuna.  
3 verschillende patronen, willekeurig geselecteerd en verpakt in dozen van 4 stuks.  
3 różne wzory powierzchni wybierane losowo i zapakowane w pudełka zawierające 4 sztuk.  
3 различных графических рисунков, упакованных путем случайного выбора по 4 штук в коробке.

COMBINA CON EL PAVIMENTO  
MATCHES FLOOR TILES  
ASSORTIS AUX CARREAUX DE SOL  
PASST ZU DEN BODENFLIESEN  
SI ABBINA AL PAVIMENTO  
PROPONOWANE POŁĄCZENIE Z PŁYTKĄ PODŁOGOWĄ  
СОЧЕТАЕТСЯ С НАПОЛЬНЫМ ПОКРЫТИЕМ

VULCANO  
80X80 / 60X60/40X80/15X15

PÁG. 178

1,5 x 100 Selene  
Antracita **16GA605** (12-81)

1,5 x 100 Selene  
Acero **16GA305** (12-81)

1,5 x 100 Selene  
Bronce **16GA905** (12-81)

1,5 x 100 Selene  
Plomo **16GA505** (12-81)

medida cm	nºpzax/box	m <sup>2</sup> /box	kg/box	boxes/pallet	m <sup>2</sup> /pallet	kg/pallet
31,5x100	4	1,26	19,50	55	69,30	1072,50
60x60 pavimento	3	1,08	27,50	32	34,56	880,00



Santa Justa  
Milenio

8,7mm (31,5x100)

31,5x100  
±1,5mm



WABI SABI 100 31,5X100 12<sup>3</sup>/<sub>8</sub>"X39<sup>3</sup>/<sub>8</sub>"

NUEVO NEW



WALL TILES  
REVESTIMIENTO

III Revestimiento: Wabi Concrete Blanco 31,5 x 100, Wabi Fabric Blanco 31,5 x 100, Wabi Wood Gris 31,5 x 100.  
III Pavimento: Coverlam Irati Encina 19,5 x 120.

# WABI SABI 100 31,5X100 12<sup>3/8</sup>"X39<sup>3/8</sup>"



31,5 x 100 Wabi Concrete  
Blanco **70WC401** (05-71)



31,5 x 100 Wabi Concrete  
Beige **70WC701** (05-71)



31,5 x 100 Wabi Concrete  
Gris **70WC301** (05-71)



31,5 x 100 Wabi Wood  
Blanco **70WW401** (05-73)



31,5 x 100 Wabi Wood  
Beige **70WW701** (05-73)



31,5 x 100 Wabi Wood  
Gris **70WW301** (05-73)



31,5 x 100 Wabi Fabric  
Blanco **70WF401** (05-71)



31,5 x 100 Wabi Fabric  
Beige **70WF701** (05-71)



31,5 x 100 Wabi Fabric  
Gris **70WF301** (05-71)



0,5 x 100 Steel  
**16SL30S** (12-70)



1,5 x 100 Selene  
Antracita **16GA60S** (12-81)



1,5 x 100 Selene  
Acero **16GA30S** (12-81)



1,5 x 100 Selene  
Bronce **16GA90S** (12-81)



1,5 x 100 Selene  
Plomo **16GA50S** (12-81)

### COMBINA CON EL PAVIMENTO

MATCHES FLOOR TILES  
ASSORTIS AUX CARREAUX DE SOL  
PASST ZU DEN BODENFLIESEN  
SI ABBINA AL PAVIMENTO  
PROPONOWANE POŁĄCZENIE Z PŁYTKĄ PODŁOGOWĄ  
СОЧЕТАЕТСЯ С НАПОЛЬНЫМ ПОКРЫТИЕМ

COVERLAM IRATI  
ARCE  
ENCINA  
ABETO



NUEVO NEW

REVESTIMIENTO WALL TILES

# WABI SABI 60X60 23<sup>5/8</sup>"X23<sup>5/8</sup>"

PORCELÁNICO  
PORCELAIN TILE

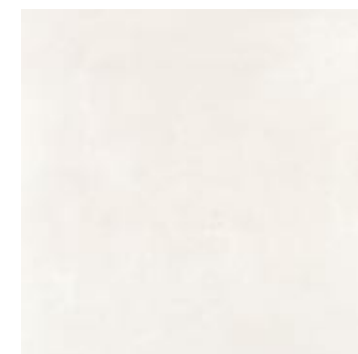

60x60 Wabi Concrete  
Blanco **52WC45R** (07-82)



60x60 Wabi Concrete  
Beige **52WC75R** (07-82)



60x60 Wabi Concrete  
Gris **52WC35R** (07-82)

medida cm	nºpzax/box	m²/box	kg/box	boxes/pallet	m²/pallet	kg/pallet
31,5x100	4	1,26	19,50	55	69,30	1.072,50
60x60	3	1,08	25,75	32	34,56	824,00



WHITE&CO 31,5X100 12<sup>3</sup>/<sub>8</sub>"X39<sup>3</sup>/<sub>8</sub>"

NUEVO NEW



III Revestimiento: Tirol Blanco 31,5 x 100, Premium Silver 31,5 x 100, Dice Blanco 31,5 x 100.  
≡ Pavimento: Montreal Cemento 80 x 80.

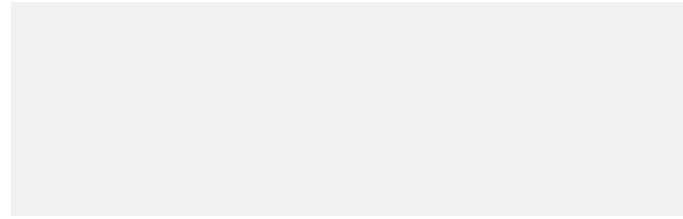

31,5 x 100 Tirol  
Blanco **70WH401** (03-85)



31,5 x 100 Hexagon  
Blanco **70WH431** (05-73)



31,5 x 100 Circle  
Blanco **70WH421** (05-73)



31,5 x 100 Premium  
Silver **70WH351** (05-73)



31,5 x 100 Line  
Blanco **70WH411** (05-73)



31,5 x 100 Hexagon  
Nude **70WH831** (05-73)



31,5 x 100 Circle  
Bronce **70WH221** (05-73)



31,5 x 100 Premium  
Rose **70WH851** (05-73)



31,5 x 100 Dice  
Blanco **70WH441** (05-73)



31,5 x 100 Hexagon  
Tinta **70WH531** (05-73)



31,5 x 100 Circle  
Acero **70WH321** (05-73)



31,5 x 100 Premium  
Gold **70WH851** (05-73)

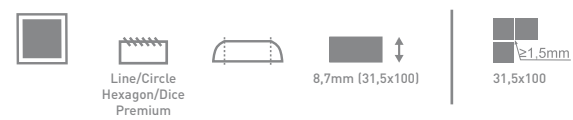

medida cm	nºpzax/box	m <sup>2</sup> /box	kg/box	boxes/pallet	m <sup>2</sup> /pallet	kg/pallet
31,5x100	4	1,26	19,50	55	69,30	1072,50

**BAHAMAS / VESUBIO 30X90 11<sup>13/16</sup>"X35<sup>7/16</sup>"**



30 x 90 Bahamas  
Blanco **66AN419** (04-50)



30 x 90 Vesubio  
Blanco **66VE409** (04-50)



30 x 90 Bahamas  
Negro **66AN919** (04-50)



30 x 90 Vesubio  
Negro **66VE909** (04-50)

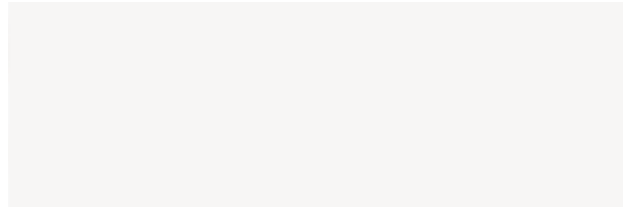

30 x 90 Antartida  
**66AN409** (04-49)



30 x 90 Vesubio  
Plata **66VE309** (04-50)

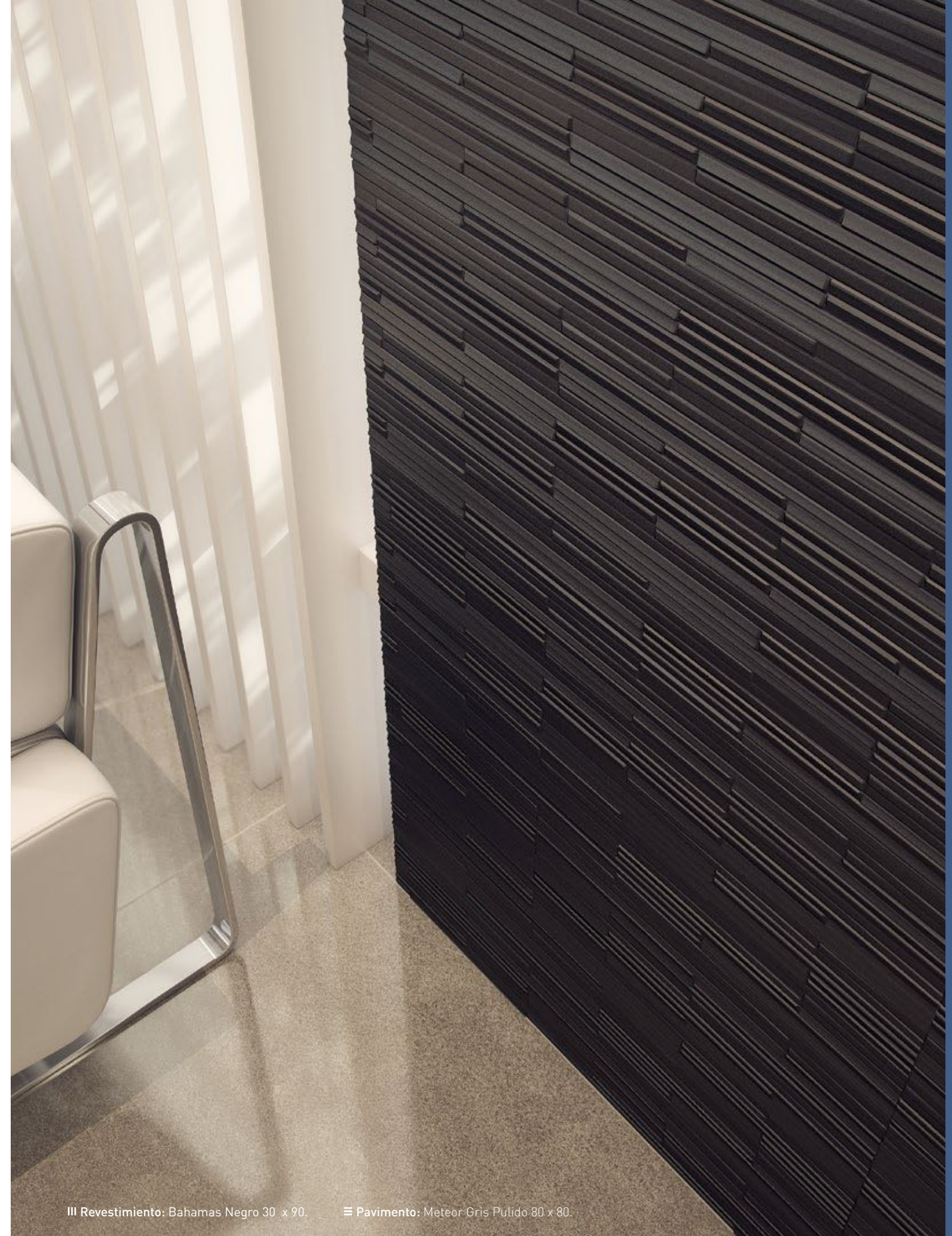

III Revestimiento: Bahamas Negro 30 x 90.    ≡ Pavimento: Meteor Gris Pólido 80 x 80.

medida cm	nºpzax/box	m²/box	kg/box	boxes/pallet	m²/pallet	kg/pallet
30x90	4	1,08	19,00	54	58,32	1.026,00



BÁLTICO 30X90 11<sup>13/16</sup>"X35<sup>7/16</sup>"



III Revestimiento: Báltico Blanco 30 x 90, Dessau Blanco 30 x 90, Tallin Blanco 30 x 30.  
≡ Pavimento: Gea Cemento 80 x 80.  
□ Mueble: Aqua 120 Seno Izquierdo Blanco.

**BÁLTICO** 30X90 11<sup>13/16</sup>"X35<sup>7/16</sup>" (TODOS LOS COLORES / ALL COLOURS)  
 31,5X100 12<sup>3/8</sup>"X39<sup>3/8</sup>" 30X60 11<sup>13/16</sup>"X23<sup>5/8</sup>" (SOLO BLANCO / ONLY WHITE)

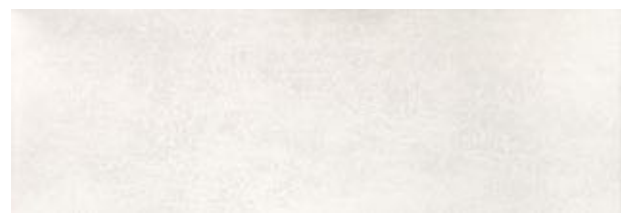

30 x 90 Báltico  
 Blanco **66BT409** (03-27)  
 31,5 x 100 Báltico  
 Blanco **70BT401** (05-71)  
 30 x 60 Báltico  
 Blanco **37BT47R** (03-12)

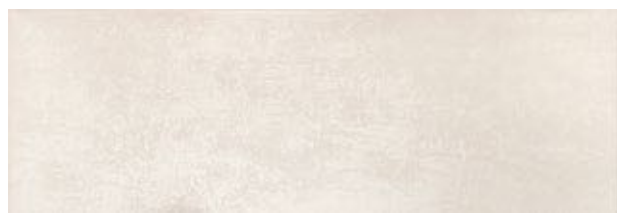

30 x 90 Báltico  
 Beige **66BT709** (03-27)



30 x 90 Báltico  
 Arena **66BT209** (03-27)



30 x 90 Báltico  
 Gris **66BT309** (03-27)

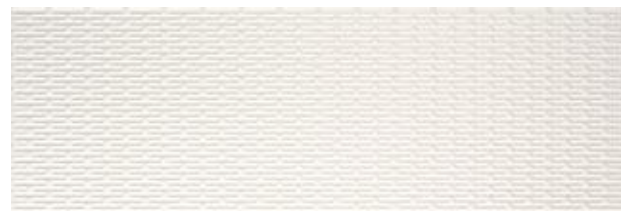

30 x 90 Bau  
 Blanco **66BT419** (04-51)



30 x 90 Bau  
 Beige **66BT719** (04-51)

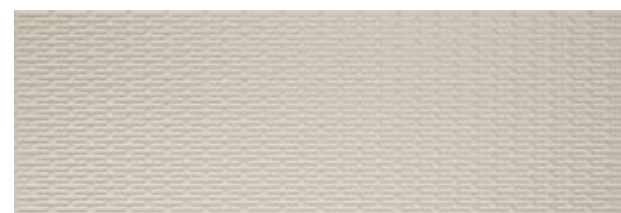

30 x 90 Bau  
 Arena **66BT219** (04-51)

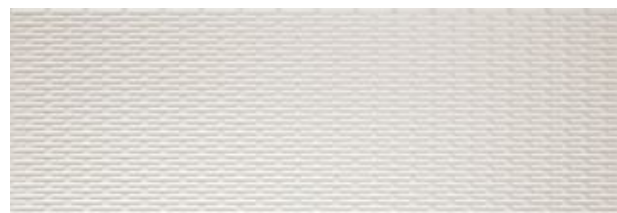

30 x 90 Bau  
 Gris **66BT319** (04-51)

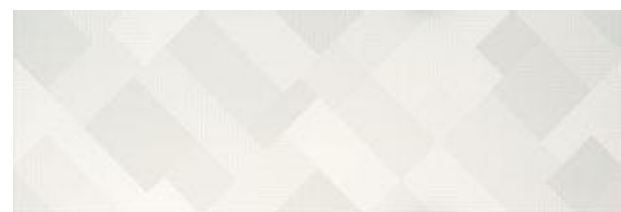

30 x 90 Dessau  
 Blanco **66BT429** (04-51)



30 x 90 Dessau  
 Beige **66BT729** (04-51)



30 x 90 Dessau  
 Arena **66BT229** (04-51)



30 x 90 Dessau  
 Gris **66BT329** (04-51)



III Revestimiento: Báltico Arena 30 x 90, Bau Arena 30 x 90.  
 ≡ Pavimento: Cambridge Caramel 19,5 x 120.  
 Π Mueble: Aqua 120 doble seno Antracita.



30 x 30 Tallin  
 Blanco **69TL-BL** (40-40)



30 x 30 Tallin  
 Beige **69TL-BG** (40-40)



30 x 30 Tallin  
 Arena **69TL-AR** (40-40)



30 x 30 Tallin  
 Gris **69TL-GR** (40-40)



30 x 90 Botnia\*  
**66BT039** (04-51)

**COMBINA CON EL PAVIMENTO**  
 MATCHES FLOOR TILES  
 ASSORTIS AUX CARREAUX DE SOL  
 PASST ZU DEN BODENFLIESEN  
 SI ABBINA AL PAVIMENTO  
 PROPONOWANE POŁĄCZENIE Z PŁYTKĄ PODŁOGOWĄ  
 СОЧЕТАЕТСЯ С НАПОЛЬНЫМ ПОКРЫТИЕМ

STARK  
 60X120/60X60

PÁG. 056

(\*) 3 gráficas diferentes empaquetadas aleatoriamente en cajas de 4 piezas.  
 3 different patterns randomly selected and packed in boxes containing 4 pieces.  
 3 verschiedene Grafiken, aleatorisch verpackt mit 4 Stück pro Karton.  
 3 graphiques différents, empaquetés par cartons de 4 pièces de façon aléatoire.  
 3 pezzi diversi, confezionati casualmente in scatole da 4 pezzi ciascuna.  
 3 verschillende patronen, willekeurig geselecteerd en verpakt in dozen van 4 stuks.  
 3 różne wzory powierzchni wybierane losowo i zapakowane w pudełko zawierające 4 sztuk.  
 3 различных графических рисунков, упакованных путем случайного выбора по 4 штук в коробке.

1,5 x 100 Selene  
 Antracita **16GA60S** (12-81)

1,5 x 100 Selene  
 Acero **16GA30S** (12-81)

1,5 x 100 Selene  
 Bronce **16GA90S** (12-81)

1,5 x 100 Selene  
 Plomo **16GA50S** (12-81)

medida cm	nºpz/as/box	m²/box	kg/box	boxes/pallet	m²/pallet	kg/pallet
30x60	7	1,26	18,64	48	60,48	894,72
30x90	4	1,08	19,00	54	58,32	1.026,00
31,5x100	4	1,26	19,50	55	60,48	1.072,50



BOSTON 90 30X90 11<sup>13/16</sup>"X35<sup>7/16</sup>"



III Revestimiento: Boston 90 Gris 30 x 90, Harvard Gris 30 x 90, Kaplan Blanco 30 x 90, Perfil Aluminio, Mystic Gris.

≡ Pavimento: Boston Gris 60 x 60.

□ Mueble: Moon 100 Nogal. Mirror Serie 3, 60 x 100.



**BOSTON 90** 30X90 11<sup>13/16</sup>"X35<sup>7/16</sup>"



30 x 90 Boston 90  
Blanco **66B0409** (03-27)



30 x 90 Boston 90  
Cemento **66B0109** (03-27)



30 x 90 Boston 90  
Gris **66B0309** (03-27)



30 x 90 Kaplan  
Blanco **66B0429** (04-50)



30 x 90 Boston 90  
Antracita **66B0609** (03-27)



30 x 90 Boston 90  
Beige **66B0709** (03-27)



30 x 90 Kaplan  
Beige **66B0729** (04-50)



30 x 90 Harvard  
Blanco **66B0419** (04-50)



30 x 90 Harvard  
Cemento **66B0119** (04-50)



30 x 90 Harvard  
Gris **66B0319** (04-50)

1,5 x 90 Perfil Aluminio  
**16F030P** (13-60)

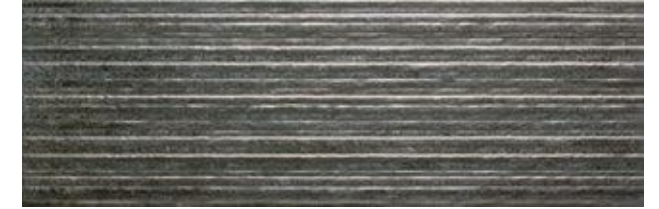

30 x 90 Harvard  
Antracita **66B0619** (04-50)



30 x 90 Harvard  
Beige **66B0719** (04-50)

**BOSTON 45X45** 17<sup>3/4</sup>"X17<sup>3/4</sup>"

PORCELÁNICO  
PORCELAIN TILE

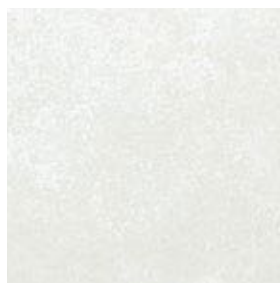

45 x 45 Boston  
Blanco **42B0-48** (07-60)



IV 45 x 45 Boston  
Gris **42B0-38** (07-60)



IV 45 x 45 Boston  
Cemento **42B0-18** (07-60)



IV 45 x 45 Boston  
Antracita **42B0-68** (07-60)

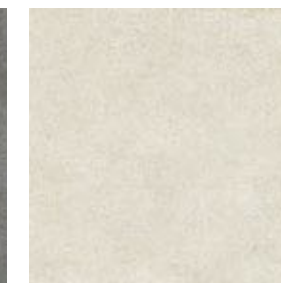

IV 45 x 45 Boston  
Beige **42B0-78** (07-60)



III Revestimiento: Harvard Gris 30 x 90.

medida cm	nºpzax/box	m²/box	kg/box	boxes/pallet	m²/pallet	kg/pallet
30x90	4	1,08	19,00	54	58,32	1.026,00
45x45	5	101	23,30	66	66,66	1.537,80



Harvard

# CASTILLA 30X90 11<sup>13/16</sup>"X35<sup>7/16</sup>"



30 x 90 Castilla  
Blanco **66CS409** (04-50)



30 x 90 Astorga  
Blanco **17CS43A** (20-15)



3 x 90 Astorga 6  
Blanco **16CS46A** (13-71)

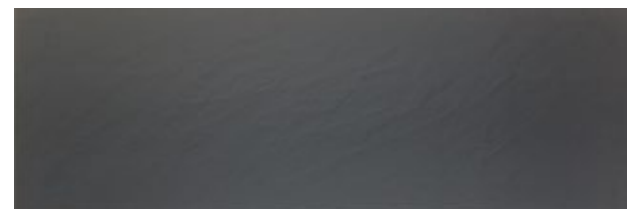

30 x 90 Castilla  
Negro **66CS909** (04-50)



30 x 30 Musa  
Titanio  
**69MU-TI** (40-40)



30 x 90 Astorga  
Negro **17CS93A** (20-15)



30 x 30 Musa  
Marquina  
**69MU-MA** (40-40)



3 x 90 Astorga 6  
Negro **16CS96A** (13-71)



1,5 x 90 Perfil Aluminio  
**16FO30P** (13-60)

## COMBINA CON EL PAVIMENTO

MATCHES FLOOR TILES  
ASSORTIS AUX CARREAUX DE SOL  
PASST ZU DEN BODENFLIESEN  
SI ABBINA AL PAVIMENTO  
PROPONOWANE POŁĄCZENIE Z PŁYTKĄ PODŁOGOWĄ  
СОЧЕТАЕТСЯ С НАПОЛЬНЫМ ПОКРЫТИЕМ

ALPES  
Negro  
MELTEMI  
Negro

PÁG.030

PÁG.334



III Revestimiento: Castilla Negro 30 x 90 / Blanco 30 x 90, Astorga Negro 30 x 90 / Blanco 30 x 90, Perfil Aluminio.

medida cm	nºpzas/box	m²/box	kg/box	boxes/pallet	m²/pallet	kg/pallet
30x90	4	1,08	19,00	54	58,32	1.026,00

COREA / MONTBLANC 30X90 11<sup>13/16</sup>"X35<sup>7/16</sup>"



30 x 90 Corea  
Blanco **63CO409** (06-40)



1,7 x 90 Cubrecanto 6 Corea  
Blanco **16CUC04** (13-97)

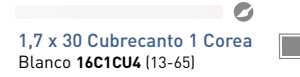

1,7 x 30 Cubrecanto 1 Corea  
Blanco **16C1CU4** (13-65)

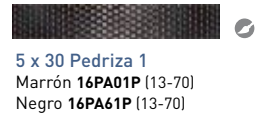

5 x 30 Pedriza 1  
Marrón **16PA01P** (13-70)  
Negro **16PA61P** (13-70)



10 x 90 Pedriza 6  
Marrón **16PA06P** (20-40)



1,5 x 90 Perfil Aluminio  
**16F030P** (13-60)

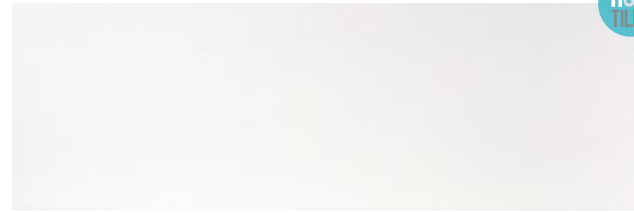

30 x 90 Montblanc  
Blanco **63MB409** (06-40)



30 x 90 Montblanc  
Beige **63MB709** (06-40)



1,7 x 90 Cubrecanto 6 Montblanc  
Blanco **16CUMB4** (13-97)  
Beige **16CUMB7** (13-97)

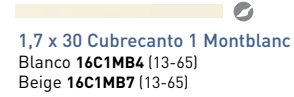

1,7 x 30 Cubrecanto 1 Montblanc  
Blanco **16C1MB4** (13-65)  
Beige **16C1MB7** (13-65)

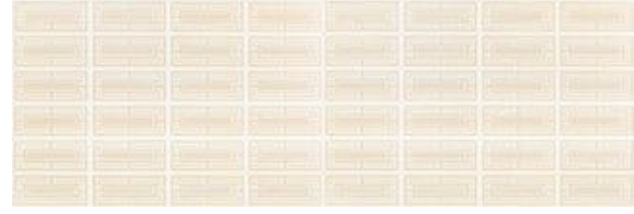

30 x 90 Locarno  
Blanco **17MB43L** (20-30)  
Beige **17MB73L** (20-30)

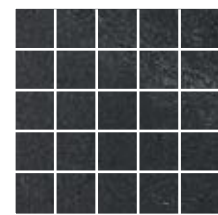

30 x 30 Zambeze  
Negro **41NB90Z** (09-05)

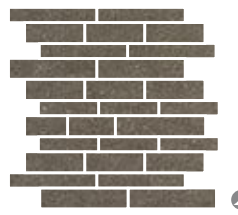

30 x 30 Jupiter Natural  
Moka **41JU-20** (13-77)  
30 x 30 Jupiter Relieve  
Moka **41JU20R** (13-77)



30 x 30 Musa  
Rectangular Negro  
**69MU-RN** (40-40)

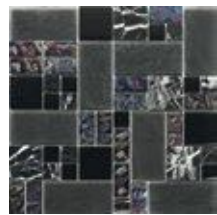

30 x 30 Musa  
Marquina  
**69MU-MA** (40-40)



30 x 30 Musa  
Carrara **69MU-CA** (40-40)

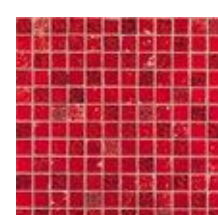

30 x 30 Musa  
Rojo **69MU-RO** (40-40)



30 x 30 Musa  
Rectangular Marrón **69MU-RM** (40-40)



III Revestimiento: Montblanc blanco 30 x 90 ≡ Pavimento: Bilbao antracita 60x60



medida cm	nºpzax/box	m²/box	kg/box	boxes/pallet	m²/pallet	kg/pallet
30x90 rectificado	4	1,08	19,00	54	58,32	1.026,00

# ESTUCO 30X90 11<sup>13/16</sup>"X35<sup>7/16</sup>"



30 x 90 Estuco  
Blanco **66TC409** (03-27)



30 x 90 Wall  
Blanco **66TC419** (04-50)



30 x 90 Wave  
Blanco **66TC429** (04-50)



30 x 90 Dots  
Blanco **17TC43D** (13-78)



30 x 90 Estuco  
Beige **66TC709** (03-27)



30 x 90 Wall  
Beige **66TC719** (04-50)



30 x 90 Wave  
Beige **66TC729** (04-50)

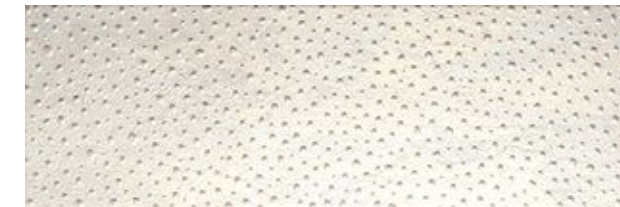

30 x 90 Dots  
Beige **17TC73D** (13-78)



30 x 90 Estuco  
Gris **66TC309** (03-27)



30 x 90 Wall  
Gris **66TC319** (04-50)



30 x 90 Wave  
Gris **66TC329** (04-50)



30 x 90 Dots  
Gris **17TC33D** (13-78)



30 x 90 Estuco  
Natural **66TC009** (03-27)



30 x 90 Wall  
Natural **66TC019** (04-50)



30 x 90 Wave  
Natural **66TC029** (04-50)



30 x 90 Dots  
Natural **17TC03D** (13-78)

# ESTUCO 60X60 23<sup>5/8</sup>"X23<sup>5/8</sup>"

PORCELÁNICO  
PORCELAIN TILE

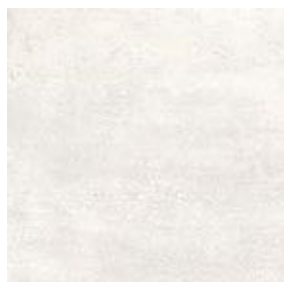

60x60 Estuco  
Blanco **52TC45R** (07-83)



60x60 Estuco  
Beige **52TC75R** (07-83)



60x60 Estuco  
Gris **52TC35R** (07-83)



60x60 Estuco  
Natural **52TC05R** (07-83)

# KILIM 60X60 23<sup>5/8</sup>"X23<sup>5/8</sup>"

PORCELÁNICO  
PORCELAIN TILE

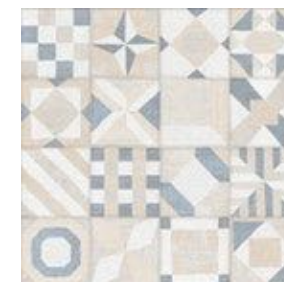

60x60 Kilim\*  
Blanco **52TC415** (07-89)



60x60 Kilim\*  
Beige **52TC715** (07-89)

(\* ) 2 gráficas diferentes empaquetadas aleatoriamente en cajas de 3 piezas.  
2 different patterns randomly selected and packed in boxes containing 3 pieces.  
2 verschiedene Grafiken, aleatorisch verpackt mit 3 Stück pro Karton.  
2 graphiques différents, empaquetés par cartons de 3 pièces de façon aléatoire.  
2 pezzi diversi, confezionati casualmente in scatole da 3 pezzi ciascuna.  
2 verschillende patronen, willekeurig geselecteerd en verpakt in dozen van 3 stuks  
2 różne wzory powierzchni wybierane losowo i zapakowane w pudetka zawierające 3 sztuk.  
2 различных графических рисунков, упакованных путем случайного выбора по 3 штук в коробке.



medida cm	nºpzax/box	m <sup>2</sup> /box	kg/box	boxes/pallet	m <sup>2</sup> /pallet	kg/pallet
30x90	4	1,08	19,00	54	58,32	1.026,00
60x60 pavimento	3	1,08	25,75	32	34,56	824,00

# ESTUCO 30X90 11<sup>13/16</sup>"X35<sup>7/16</sup>"



30 x 90 Kilim\*  
Blanco **66TC449** [04-50]



30 x 90 Kilim\*  
Beige **66TC749** [04-50]



30 x 90 Tapis\*  
Blanco **66TC439** [04-50]



30 x 90 Tapis\*  
Beige **66TC739** [04-50]

1,5 x 100 Selene  
Antracita **16GA605** [12-81]

1,5 x 100 Selene  
Acero **16GA305** [12-81]

1,5 x 100 Selene  
Bronce **16GA905** [12-81]

1,5 x 100 Selene  
Plomo **16GA505** [12-81]

[\*] 3 gráficas diferentes empaquetadas aleatoriamente en cajas de 3 piezas.  
3 different patterns randomly selected and packed in boxes containing 3 pieces.  
3 verschiedene Grafiken, aleatorisch verpackt mit 3 Stück pro Karton.  
3 graphiques différents, empaquetés par cartons de 3 pièces de façon aléatoire.  
3 pezzi diversi, confezionati casualmente in scatole da 3 pezzi cadauna.  
3 verschillende patronen, willekeurig geselecteerd en verpakt in dozen van 3 stuks  
3 różne wzory powierzchni wybierane losowo i zapakowane w pudełka zawierające 3 sztuk.  
3 различных графических рисунков, упакованных путем случайного выбора по 3 штук в коробке.



III Revestimiento: Estuco Gris 30 x 90, Kilim Blanco 30 x 90.

III Pavimento: Estuco Gris 60 x 60, Kilim Blanco 60 x 60.



medida cm	nºpzax/box	m²/box	kg/box	boxes/pallet	m²/pallet	kg/pallet
30x90	4	1,08	19,00	54	58,32	1.026,00
60x60 pavimento	3	1,08	25,75	32	34,56	824,00

**FUTURA 30X90 11<sup>13/16</sup>"X35<sup>7/16</sup>"**



Nacar **66FU409** (04-50)

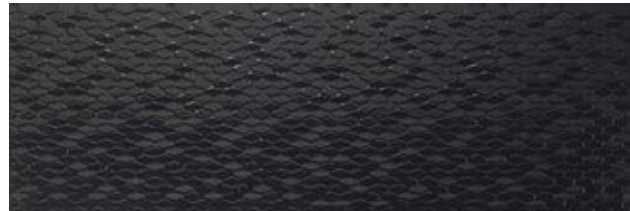

Negro **66FU909** (04-50)



Plata **66FU309** (04-50)

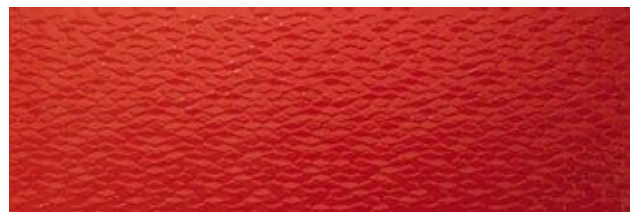

Rojo **66FU209** (04-50)



Oro **17FU03F** (20-18)



III Revestimiento: Futura Nacar 30 x 90.

≡ Pavimento: Basilea Gris 45 x 90.

medida cm	nºpzax/box	m <sup>2</sup> /box	kg/box	boxes/pallet	m <sup>2</sup> /pallet	kg/pallet
30x90	4	1,08	19,00	54	58,32	1.026,00



LORD 30X90 11<sup>13/16</sup>"X35<sup>7/16</sup>"



30 x 90 Lord  
Blanco 66LR409 (04-50)



30 x 90 Lord  
Marfil 66LR709 (04-50)



30 x 90 Lord  
Plata 66LR309 (04-50)



30 x 90 Lord  
Oro 66LR209 (04-50)

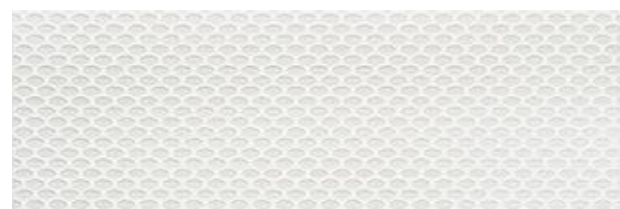

30 x 90 Club  
Blanco 66LR419 (04-53)

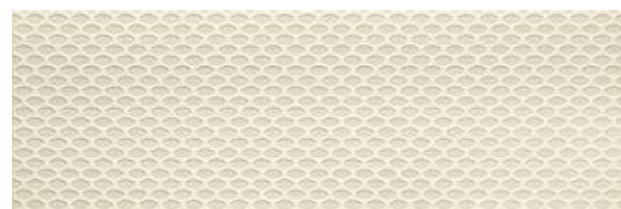

30 x 90 Club  
Marfil 66LR719 (04-53)

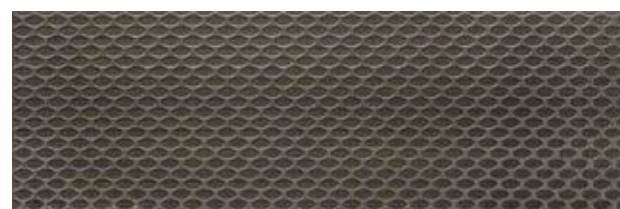

30 x 90 Club  
Plata 66LR319 (04-53)

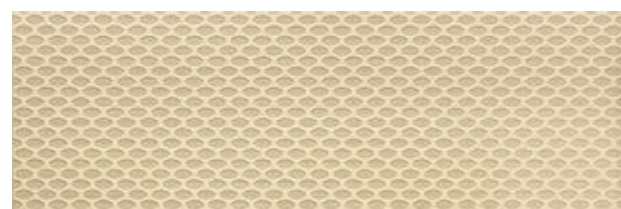

30 x 90 Club  
Oro 66LR219 (04-53)



30 x 90 Byron  
Blanco 66LR429 (04-53)



30 x 90 Byron  
Marfil 66LR729 (04-53)



30 x 90 Byron  
Plata 66LR329 (04-53)



30 x 90 Byron  
Oro 66LR229 (04-53)



III Revestimiento: Lord Plata, Club Plata, Club Blanco.  
 ≡ Pavimento: Lord Antracita 60 x 60.  
 □ Mueble: Aqua 100 Antracita. Mirror Serie 1, 60 x 100.

LORD 60X60 23<sup>5/8</sup>"X23<sup>5/8</sup>"

PORCELÁNICO  
PORCELAIN TILE



60x60 Lord  
Blanco 52LR405 (07-83) IV



60x60 Lord  
Marfil 52LR705 (07-83) IV



60x60 Lord  
Antracita 52LR605 (07-83) III

medida cm	nºpzax/box	m²/box	kg/box	boxes/pallet	m²/pallet	kg/pallet
30x90	4	1,08	19,00	54	58,32	1.026,00
60x60 pavimento	3	1,08	25,75	32	34,56	824,00



LORD 30X90 11<sup>13/16</sup>"X35<sup>7/16</sup>"

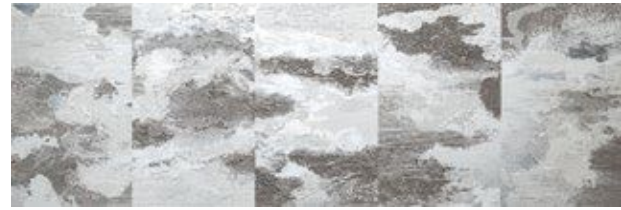

30 x 90 Eliot Blanco  
17LR43E (20-05)



30 x 90 Eliot Marfil  
17LR33E (20-05)



30 x 90 Nijo  
17LR23N (20-15)



30 x 90 Windsor  
17LR33W (20-30)



30 x 30 Musa Cristal Oro  
69MU-CR (40-75)

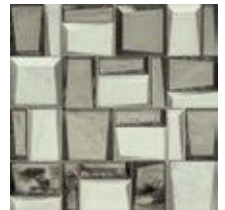

30 x 30 Musa Cristal Plata  
69MU-CP (40-75)



III Revestimiento: Lord Marfil 30 x 90, Nijo 30 x 90.



Club  
Byron



3mm

medida cm	nºpzax/box	m²/box	kg/box	boxes/pallet	m²/pallet	kg/pallet
30x90	4	1,08	19,00	54	58,32	1.026,00
60x60 pavimento	3	1,08	25,75	32	34,56	824,00



# NEPAL 30X90 11<sup>13/16</sup>"X35<sup>7/16</sup>"

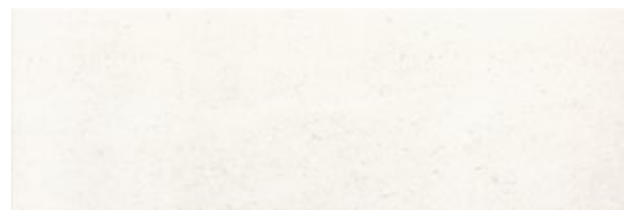

30 x 90 Nepal  
Blanco **66NP409** (07-83)



30 x 90 Nepal  
Beige **66NP709** (07-83)



30 x 90 Nepal  
Gris **66NP309** (07-83)



30 x 90 Terai  
Blanco **66NP419** (04-53)



30 x 90 Terai  
Beige **66NP719** (04-53)



30 x 90 Terai  
Gris **66NP319** (04-53)



30 x 90 Sherpa  
Blanco **66NP435** (20-05)



30 x 90 Sherpa  
Beige **66NP735** (20-05)

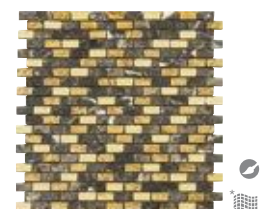

30 x 30 Musa Brick  
Emperador  
**69MUBEM** (40-40)

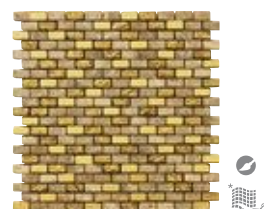

30 x 30 Musa Brick  
Capuccino  
**69MUBCA** (40-40)

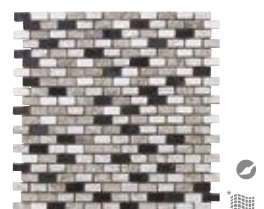

30 x 30 Musa Brick  
Sandal  
**69MUBSA** (40-40)

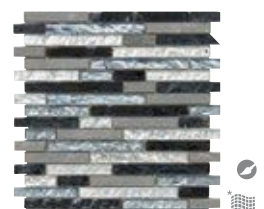

30 x 30 Musa Rectangular  
Gris  
**69MU-RG** (40-40)



III Revestimiento: Nepal beige 30 x 90, Terai Beige 30 x 90, Sherpa Beige 30 x 90.

≡ Pavimento: Nepal 45 Beige 45 x 45.

# NEPAL 45 45X45 17<sup>3/4</sup>"X17<sup>3/4</sup>"

PORCELÁNICO  
PORCELAIN TILE

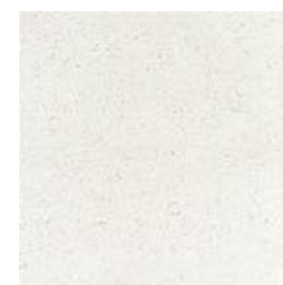

45 x 45 Nepal 45  
Blanco **42NP-48** (07-70)

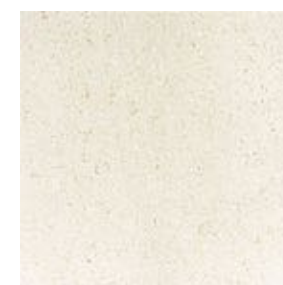

45 x 45 Nepal 45  
Beige **42NP-78** (07-70)



45 x 45 Nepal 45  
Tabaco **42NP-28** (07-70)



45 x 45 Nepal 45  
Gris **42NP-38** (07-70)

medida cm	nºpzax/box	m²/box	kg/box	boxes/pallet	m²/pallet	kg/pallet
30x90	4	1,08	19,00	54	58,32	1.026,00
45x45	5	1,01	23,30	66	66,66	1.537,80



Terai

**PALACE 90 30X90 11<sup>13/16</sup>"X35<sup>7/16</sup>"**



30 x 90 Palace 90  
Carrara **63PA409** (05-70)



1,7 x 90 Cubrecanto  
Palace 6 Carrara  
**16CUPA4** (13-97)



30 x 90 Cibeles  
**63PA40C** (06-40)

1,7 x 30 Cubrecanto Palace 1  
Carrara **16C1PA4** (13-65)



20 x 30 Zócalo  
Carrara **25PA40Z** (11-50)



10 x 30 Cibeles 1  
**16PA41C** (11-41)



30 x 30 Musa  
Carrara  
**69MU-CA** (40-40)

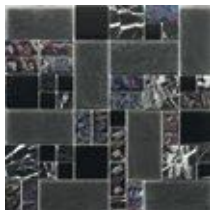

30 x 30 Musa  
Marquina  
**69MU-MA** (40-40)



30 x 30 Musa  
Rectangular Negro  
**69MU-RN** (40-40)

**COMBINA CON EL PAVIMENTO**

MATCHES FLOOR TILES  
ASSORTIS AUX CARREAUX DE SOL  
PASST ZU DEN BODENFLIESEN  
SI ABBINA AL PAVIMENTO  
PROPONOWANE POŁĄCZENIE Z PŁYTKĄ PODŁOGOWĄ  
СОЧЕТАЕТСЯ С НАПОЛЬНЫМ ПОКРЫТИЕМ

59X59 PALACE  
Carrara

PÁG.156



III Revestimiento: Palace 90 Carrara, Cibeles 30 x 90.

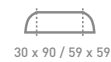

Palace 90



Palace

medida cm	nºpzax/box	m²/box	kg/box	boxes/pallet	m²/pallet	kg/pallet
30x90 rectificado	4	1,08	19,00	54	58,32	1.026,00
59x59	3	1,04	26,50	32	33,28	848,00



30 x 90 Sablier  
Blanco **66SB409** (03-27)



30 x 90 Printemps  
Blanco **66SB419** (04-50)



30 x 90 Estivale  
Blanco **66SB429** (04-50)



30 x 90 Sablier  
Beige **66SB709** (03-27)



30 x 90 Printemps  
Beige **66SB719** (04-50)



30 x 90 Estivale  
Beige **66SB729** (04-50)



30 x 90 Sablier  
Gris **66SB309** (03-27)



30 x 90 Printemps  
Gris **66SB319** (04-50)



30 x 90 Estivale  
Gris **66SB329** (04-50)



30 x 90 Automne  
Blanco **66SB439** (04-50)



30 x 90 Eclat  
Plata **66SB359** (04-54)



30 x 90 Automne  
Beige **66SB739** (04-50)



30 x 90 Eclat  
Bronce **66SB259** (04-54)



30 x 90 Automne  
Gris **66SB339** (04-50)

0,5 x 100 Steel  
**16SL30S** (12-70)

1,5 x 100 Selene  
Antracita **16GA60S** (12-81)

1,5 x 100 Selene  
Acero **16GA30S** (12-81)

1,5 x 100 Selene  
Bronce **16GA90S** (12-81)

1,5 x 100 Selene  
Plomo **16GA50S** (12-81)



30 x 30 Musa Cristal Oro  
**69MU-CR** (40-75)

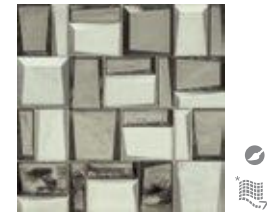

30 x 30 Musa Cristal Plata  
**69MU-CP** (40-75)



III Revestimiento: Sablier Gris 30 x 90, Printemps Gris 30 x 90    PAVIMENTO: Gea Cemento 80 x 80

medida cm	nº pzas/box	m <sup>2</sup> /box	kg/box	boxes/pallet	m <sup>2</sup> /pallet	kg/pallet
30x90	4	1,08	20,82	54	58,32	1.124,28



Printemps  
Eclat  
Automne  
Estivale

10mm

# SUECIA / ANTARTIDA 30X90 11<sup>13/16</sup>"X35<sup>7/16</sup>"

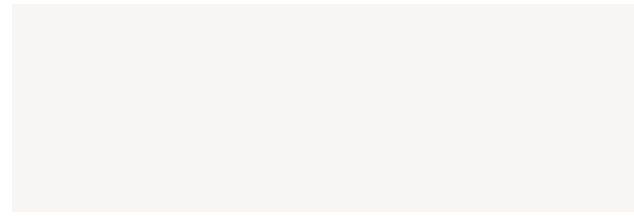

30 x 90 Suecia  
66SU409 [04-49]

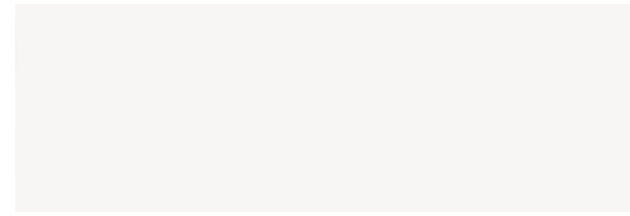

30 x 90 Antartida  
66AN409 [04-49]



30 x 90 Sarek  
Blanco 66SU429 [04-55]



30 x 90 Oasis  
Blanco 66OS409 [04-50]



30 x 90 Sarek  
Negro 66SU929 [04-55]



10 x 90 Pedriza 6  
Marrón 16PA06P [20-40]



5 x 30 Pedriza 1  
Marrón 16PA01P [13-70]  
Negro 16PA61P [13-70]



30 x 30 Musa  
Damasco Negro  
69MU-DN [40-70]



30 x 30 Musa Brick  
Sandal  
69MUBSA [40-40]



30x30 Saona  
Galena 41LY50S [13-71]



30 x 30 Ethosa  
Negro 41NB90E [13-05]



30 x 30 Amadora  
Antracita 41SI50A [13-05]



30x30 Reserva  
Bobal 41CV10R [09-05]



19,2x38,4 Saturno  
Corten 08SA-20 [13-71]  
Iron 08SA-90 [13-71]  
Galena 08SA-60 [13-71]  
Silver 08SA-30 [13-71]

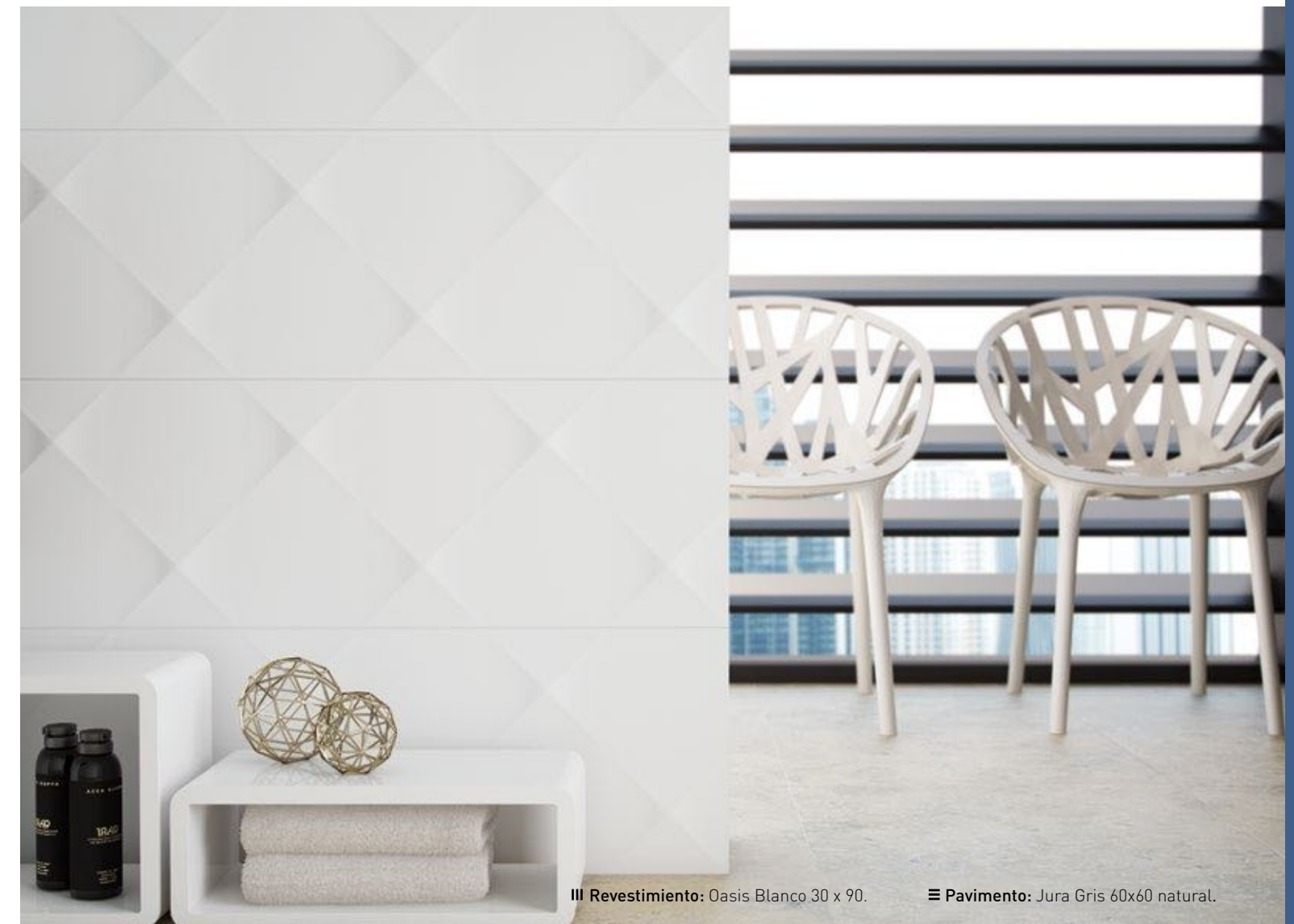

III Revestimiento: Oasis Blanco 30 x 90.

III Pavimento: Jura Gris 60x60 natural.

medida cm	nºpzax/box	m²/box	kg/box	boxes/pallet	m²/pallet	kg/pallet
30x90 rectificado	4	1,08	19,00	54	58,32	1.026,00



Suecia  
Sarek



Antartida  
Oasis



Oasis  
Sarek



# CHICAGO 30X60 11<sup>13/16</sup>"X23<sup>5/8</sup>"



30 x 60 Chicago  
Blanco **37CI407** (07-68)



30 x 60 Chicago  
Gris **37CI307** (07-68)



30 x 60 Chicago  
Antracita **37CI607** (07-68)

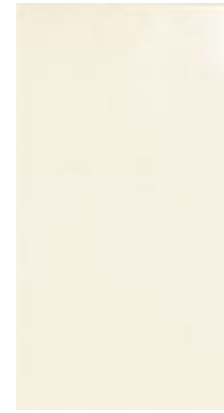

30 x 60 Chicago  
Beige **37CI707** (07-68)



30 x 60 Chicago  
Marrón **37CI007** (07-68)

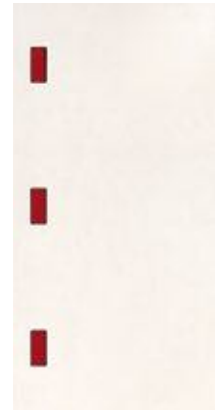

3 x 30 Kavala  
Negro **16CI61K** (12-91)  
Marrón **16CI01K** (12-91)



2,5 x 30 Madison 1  
Negro **16CI61M** (12-65)

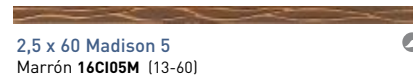

2,5 x 60 Madison 5  
Marrón **16CI05M** (13-60)



2,5 x 60 Fez 5  
Marrón **16CI05F** (13-60)

30 X 60 Detroit 3  
Blanco **17CI43D** (13-72)  
Beige **17CI73D** (13-72)  
Gris **17CI33D** (13-72)

2 x 30 Detroit 1  
Rojo **16CI21D** (12-90)

2 x 30 Detroit 1  
Naranja **16CI81D** (12-90)

# KANSAS 30X30 11<sup>13/16</sup>"X11<sup>13/16</sup>"

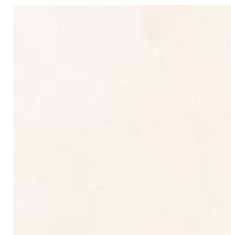

Blanco **40KA-40** (01-53) IV



Gris **40KA-30** (01-53) III



Antracita **40KA-90** (01-53) III



Beige **40KA-70** (01-53) IV



Marrón **40KA-20** (01-53) III

Rodapié  
8x30 (10-65)

PORCELÁNICO  
PORCELAIN TILE



III Revestimiento: Chicago Gris y Antracita 30 x 60, Detroit 3 Gris 30 x 60.



III Revestimiento: Chicago Beige y Marrón 30 x 60, Madison 5 Marrón 2,5 x 60.

medida cm	nºpzax/box	m²/box	kg/box	boxes/pallet	m²/pallet	kg/pallet
30x60	7	1,26	18,64	48	60,48	894,72
30x30	11	1,00	19,90	48	64,00	955,20



COLUMBIA 60 30X60 11<sup>13/16</sup>" X 23<sup>5/8</sup>"



III Revestimiento: Columbia Blanco 30 x 60, Yoho Antracita 30 x 60, Comox Blanco 30 x 60. III Pavimento: Columbia 45 Antracita.

**COLUMBIA 60** 30X60 11<sup>13/16</sup>"X23<sup>5/8</sup>"



30 x 60 Columbia 60  
Blanco **37CL407** (01-85)



30 x 60 Columbia 60  
Gris **37CL307** (01-85)



30 x 60 Columbia 60  
Antracita **37CL607** (01-85)

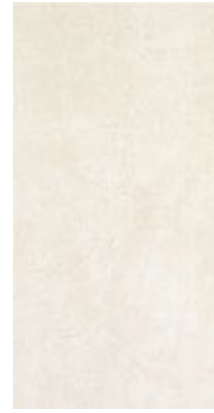

30 x 60 Columbia 60  
Beige **37CL707** (01-85)



30 x 60 Columbia 60  
Marrón **37CL007** (01-85)



30 x 60 Comox  
Blanco **37CL40C** (03-60)



30 x 60 Comox  
Gris **37CL30C** (03-60)

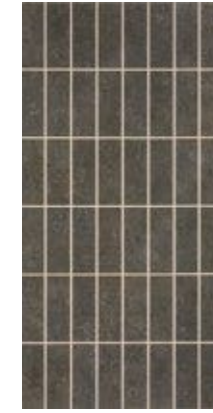

30 x 60 Comox  
Antracita **37CL60C** (03-60)



30 x 60 Comox  
Beige **37CL70C** (03-60)



30 x 60 Comox  
Marrón **37CL00C** (03-60)



1,5 x 60 Sami 6  
Acero **160L365** (13-76)



30 x 60 Cezanne 3  
Gris **17CL33C** (13-95)  
Marrón **17CL03C** (13-95)



9,4 x 60 Cezanne  
Gris **16DE36C** (13-68)  
Marrón **16DE06C** (13-68)



9 x 60 Degas-6  
Gris **16DE36D** (13-30)  
Marrón **16DE06D** (13-30)



30 x 60 Yoho  
Marrón **17CL03Y** (13-95)  
Antracita **17CL63Y** (13-95)



7x60 Yoho 6  
Marrón **16CL06Y** (13-11)  
Antracita **16CL66Y** (13-11)



4,5 x 30 Degas-1  
Gris **16DE31D** (11-71)  
Marrón **16DE01D** (11-71)

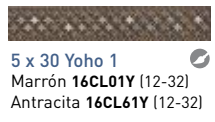

5 x 30 Yoho 1  
Marrón **16CL01Y** (12-32)  
Antracita **16CL61Y** (12-32)

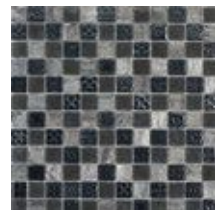

30 x 30 Musa  
Oceano **69MU-OC** (40-40)



30 x 30 Musa  
Rectangular Negro **69MU-RN** (40-40)



30 x 30 Musa  
Ferro **69MU-FE** (40-40)



30 x 30 Musa  
Bronce **69MU-BR** (40-40)



30 x 30 Musa  
Rectangular Marrón **69MU-RM** (40-40)

**COLUMBIA 45** 45X45 17<sup>3/4</sup>"X17<sup>3/4</sup>"

PORCELÁNICO  
PORCELAIN TILE

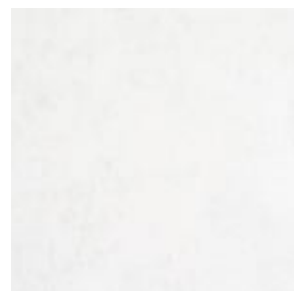

Blanco **42CU-48** (07-73)



V Gris **42CU-38** (07-73)



IV Antracita **42CU-68** (07-73)

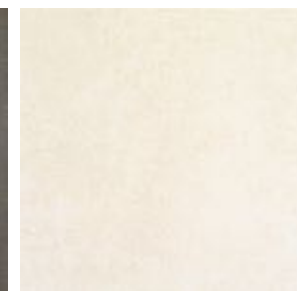

IV Beige **42CU-78** (07-73)

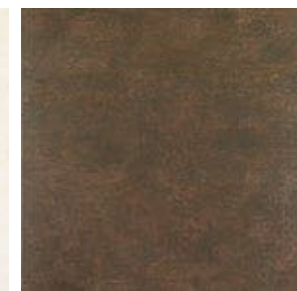

IV Marrón **42CU-28** (07-73)

IV



III Revestimiento: Columbia Beige y Marrón 30 x 60, Cezanne 3 Marrón.

medida cm	nºpzas/box	m²/box	kg/box	boxes/pallet	m²/pallet	kg/pallet
30x60	7	1,26	18,64	48	60,48	894,72
45x45 pavimento	5	1,01	23,30	66	66,66	1.537,80



CRETA 30X60 11<sup>13/16</sup>"X23<sup>5/8</sup>"



III Revestimiento: Creta Blanco 30 x 60, Talos Antracita 30 x 60, Icaro Gris 30 x 60.  
≡ Pavimento: Creta Gris 60 x 60  
□ Mueble: Aqua 120 seno izquierdo Blanco, Mueble Cajonero 100 Blanco. Mirrор Serie 1 80 x 50.



# CRETA 30X60 11<sup>13/16</sup>" X 23<sup>5/8</sup>"



30 x 60 Creta  
Blanco **37CR407** (03-04)



30 x 60 Creta  
Beige **37CR707** (03-04)



30 x 60 Creta  
Visión **37CR007** (03-04)



30 x 60 Creta  
Gris **37CR307** (03-04)



30 x 60 Creta  
Antracita **37CR607** (03-04)



30 x 60 Talos  
Blanco **37CR427** (03-06)



30 x 60 Talos  
Beige **37CR727** (03-06)



30 x 60 Talos  
Vison **37CR027** (03-06)



30 x 60 Talos  
Gris **37CR327** (03-06)



30 x 60 Talos  
Antracita **37CR627** (03-06)

# CRETA 45X45 17<sup>3/4</sup>" X 17<sup>3/4</sup>" 60X60 23<sup>5/8</sup>" X 23<sup>5/8</sup>"

PORCELÁNICO  
PORCELAIN TILE



45x45 Creta  
Blanco **42CR-48** (07-60)  
60x60 Creta  
Blanco **52CT45R** (07-83)

IV

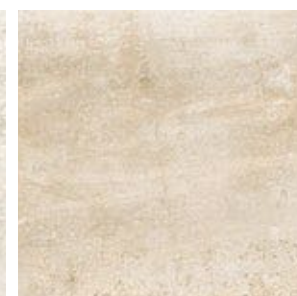

45x45 Creta  
Beige **42CR-78** (07-60)  
60x60 Creta  
Beige **52CT75R** (07-83)

IV

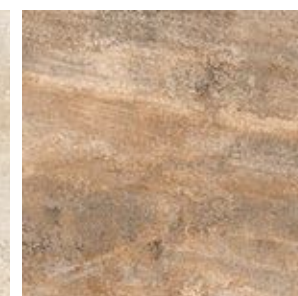

45x45 Creta  
Vison **42CR-08** (07-60)  
60x60 Creta  
Vison **52CT05R** (07-83)

IV



45x45 Creta  
Gris **42CR-38** (07-60)  
60x60 Creta  
Gris **52CT35R** (07-83)

IV



45x45 Creta  
Antracita **42CR-68** (07-60)  
60x60 Creta  
Antracita **52CT65R** (07-83)

IV



Talos  
60x60/45x45



30x60  
45x45



60x60



3mm  
60x60/45x45



30,9 x 31,1 Musa Klimt  
Marrón **69MU-KM** (40-60)



30,9 x 31,1 Musa Klimt  
Antracita **69MU-KA** (40-60)

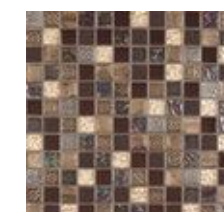

30 x 30 Musa  
Bronce **69MU-BR** (40-40)



26,4 x 27,4 Musa Exagono  
Marrón **69MU-EM** (40-70)



26,4 x 27,4 Musa Exagono  
Negro **69MU-EN** (40-70)



30 x 30 Musa Rectangular  
Marrón **69MU-RM** (40-40)

medida cm	nºpz/box	m²/box	kg/box	boxes/pallet	m²/pallet	kg/pallet
30x60	7	1,26	18,64	48	60,48	894,72
45x45 pavimento	5	1,01	23,30	66	66,66	824,00
60x60 pavimento	3	1,08	25,75	32	34,56	880,00



30 x 60 Festos (set de 2 piezas)  
Visión **17CR03F** (13-81)



30 x 60 Festos (set de 2 piezas)  
Blanco **17CR43F** (13-81)



30 x 60 Festos (set de 2 piezas)  
Beige **17CR73F** (13-81)



30 x 60 Festos (set de 2 piezas)  
Gris **17CR33F** (13-81)



30 x 60 Festos (set de 2 piezas)  
Antracita **17CR63F** (13-81)



30 x 60 Icaro\*  
Visión **27CR017** (03-06)



30 x 60 Icaro\*  
Gris **27CR317** (03-06)

(\*) 4 gráficas diferentes empaquetadas aleatoriamente en cajas de 6 piezas.  
4 different patterns randomly selected and packed in boxes containing 6 pieces.  
4 verschiedene Grafiken, aleatorisch verpackt mit 6 Stück pro Karton.  
4 graphiques différents, empaquetés par cartons de 6 pièces de façon aléatoire.  
4 pezzi diversi, confezionati casualmente in scatole da 6 pezzi ciascuna.  
4 verschillende patronen, willekeurig geselecteerd en verpakt in dozen van 6 stuks  
4 różnych wzorów powierzchni wybieranych losowo i zapakowane w pudełkach zawierające 6 sztuk.  
4 различных графических рисунков, упакованных путем случайного выбора по 6 штук в коробке.

# EDEN 30X60 11<sup>13/16</sup>"X23<sup>5/8</sup>"

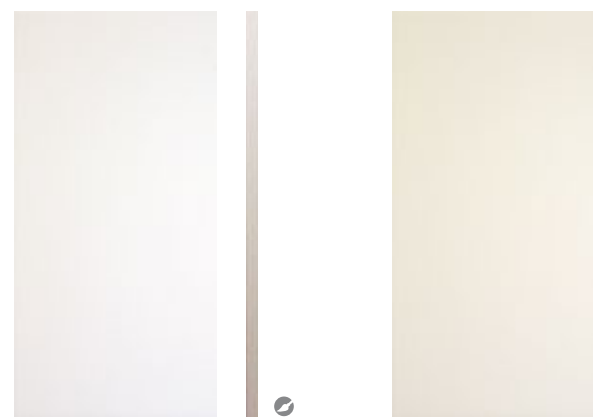

30 x 60 Eden Blanco **37ED407** (02-63)  
 1,5 x 60 Sami 6 Acero **16L365** (13-76)  
 30 x 60 Eden Beige **37ED707** (02-63)

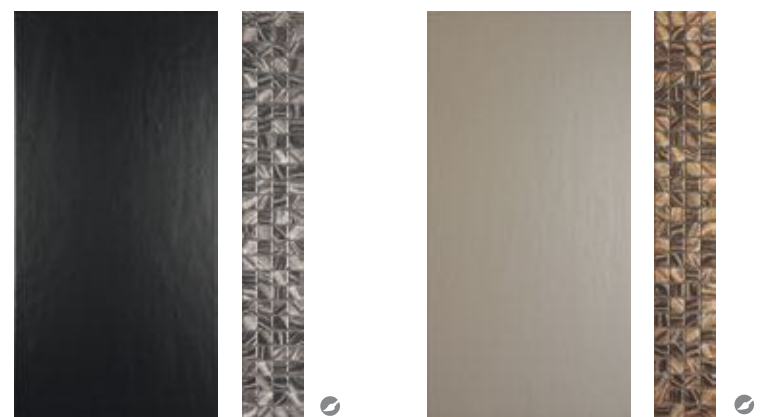

30 x 60 Eden Negro **37ED607** (02-63)  
 9 x 60 Degas-6 Gris **16DE36D** (13-30)  
 30 x 60 Eden Marrón **37ED007** (02-63)  
 9 x 60 Degas-6 Marrón **16DE06D** (13-30)

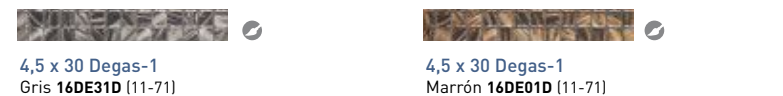

4,5 x 30 Degas-1 Gris **16DE31D** (11-71)  
 4,5 x 30 Degas-1 Marrón **16DE01D** (11-71)

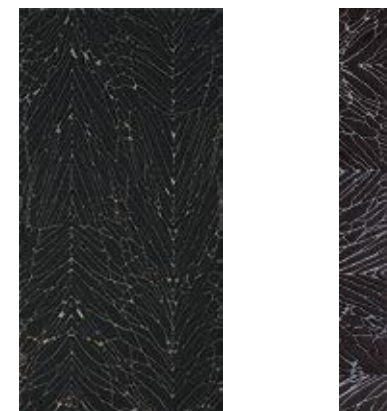

30 x 60 Bosco Negro **17ED60B** (13-95)  
 Beige **17ED70B** (13-95)  
 Blanco **17ED40B** (13-95)  
 Marrón **17ED00B** (13-95)  
 7 x 60 Bosco 6 Negro **16ED66B** (13-11)  
 Beige **16ED76B** (13-11)  
 Blanco **16ED46B** (13-11)  
 Marrón **16ED06B** (13-11)



30x30 Reserva Bobal **41CV10R** (09-05)  
 30x30 Saona Galena **41LY50S** (13-71)



30 x 30 Ethosa Negro **41NB90E** (13-05)  
 30 x 30 Musa Rectangular Negro **69MU-RN** (40-40)  
 30 x 30 Musa Marquina **69MU-MA** (40-40)

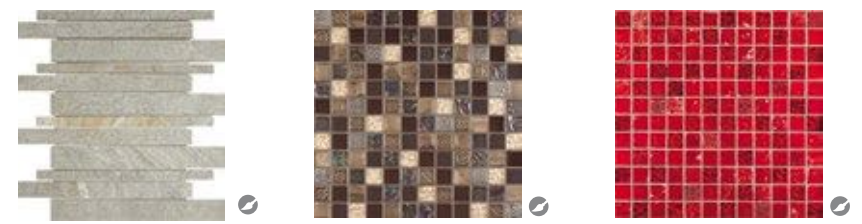

30 x 30 Amadora Antracita **41SI50A** (13-05)  
 30 x 30 Musa Bronce **69MU-BR** (40-40)  
 30 x 30 Musa Rojo **69MU-RO** (40-40)

## COMBINA CON EL PAVIMENTO

MATCHES FLOOR TILES  
 ASSORTIS AUX CARREAUX DE SOL  
 PASST ZU DEN BODENFLIESEN  
 SI ABBINA AL PAVIMENTO  
 PROPONOWANE POŁĄCZENIE Z PŁYTKĄ PODŁOGOWĄ  
 СОЧЕТАЕТСЯ С НАПОЛЬНЫМ ПОКРЫТИЕМ

## MULTIFORMATO

ALPES PÁG.030  
 CUBANA PÁG.110  
 METEOR PÁG.044



III Revestimiento: Eden Blanco y Negro 30 x 60, Bosco Blanco 30 x 60, Bosco 6 Negro 7 x 60.  
 II Mueble: Ada 80 Blanco. Mirror Serie 1 80 x 60.

III Pavimento: Meteor Negro Pulido 60 x 60.

medida cm	nºpzax/box	m²/box	kg/box	boxes/pallet	m²/pallet	kg/pallet
30x60	7	1,26	18,64	48	60,48	894,72



# FINLANDIA / SIBERIA 30X60 11<sup>13/16</sup>"X23<sup>5/8</sup>"



30 x 60 Finlandia Blanco **37FI407** (03-25)  
Blanco **37FI47R** (03-35)

30 x 60 Finlandia Beige **37FI707** (03-25)

30 x 60 Kiel Blanco **31FI427** (03-60)

30 x 60 Siberia Blanco **37SI407** (03-25)  
Blanco **37SI47R** (03-35)

1,5 x 60 Glass 4  
Burdeos **16RA84G** (13-05)  
Marrón **16RA04G** (13-05)  
Azul **16RA54G** (13-05)  
Metal **16PT94G** (13-05)

1,5 x 60 Sami 6  
Oro **16OL26S** (13-76)  
Acero **16OL36S** (13-76)

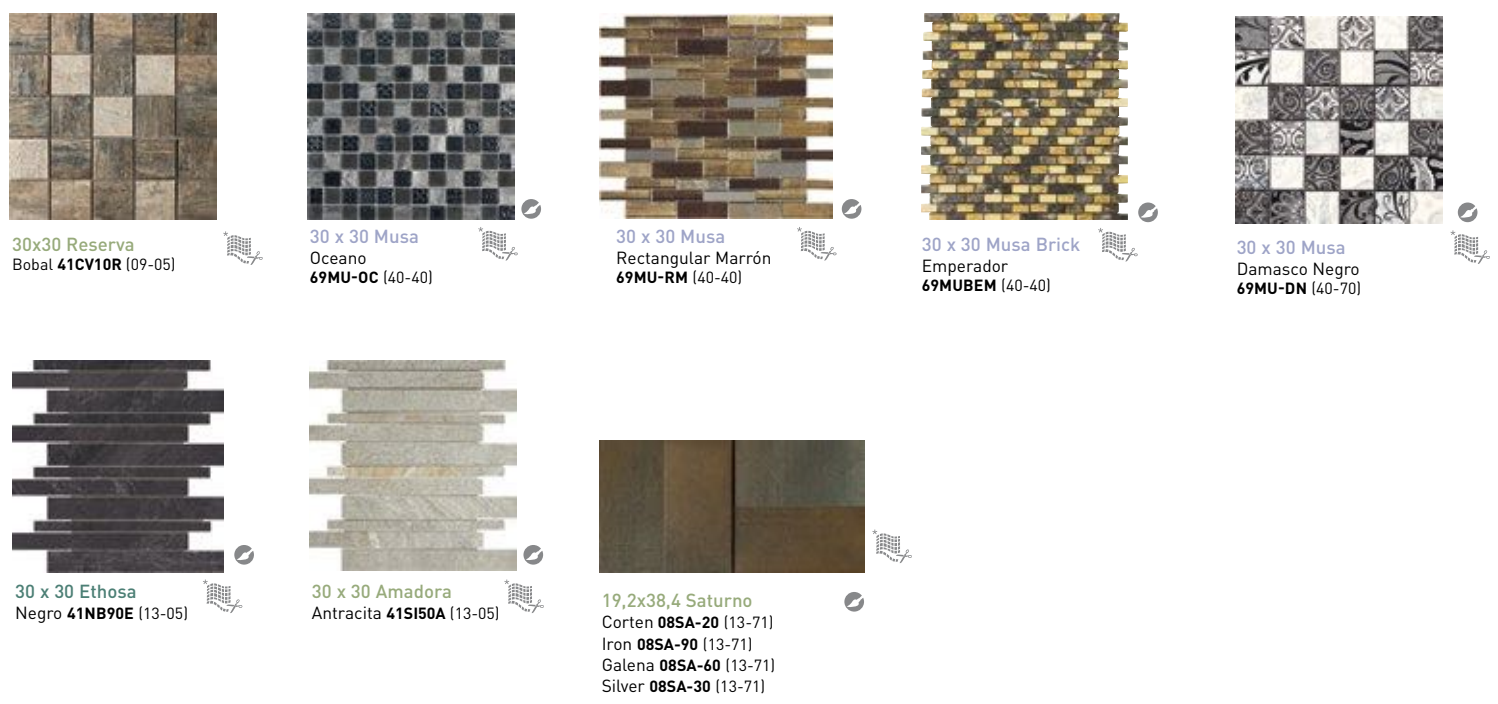

30x30 Reserva Bobal **41CV10R** (09-05)

30 x 30 Musa Oceano **69MU-OC** (40-40)

30 x 30 Musa Rectangular Marrón **69MU-RM** (40-40)

30 x 30 Musa Brick Emperador **69MUBEM** (40-40)

30 x 30 Musa Damasco Negro **69MU-DN** (40-70)

30 x 30 Ethosa Negro **41NB90E** (13-05)

30 x 30 Amadora Antracita **41SI50A** (13-05)

19,2x38,4 Saturno Corten **08SA-20** (13-71)  
Iron **08SA-90** (13-71)  
Galena **08SA-60** (13-71)  
Silver **08SA-30** (13-71)

**COMBINA CON EL PAVIMENTO**  
MATCHES FLOOR TILES  
ASSORTIS AUX CARREAUX DE SOL  
PASST ZU DEN BODENFLIESEN  
SI ABBINA AL PAVIMENTO  
PROPONOWANE POŁĄCZENIE Z PŁYTKĄ PODŁOGOWĄ  
СОЧЕТАЕТСЯ С НАПОЛЬНЫМ ПОКРЫТИЕМ

**MULTIFORMATO**  
BILBAO PÁG.086  
CANAIMA PÁG.102  
HOMESTONE PÁG.126



III Revestimiento: Siberia Blanco 30 x 60.      ≡ Pavimento: Cubana Abeto 19,5 x 120.

□ Mueble: Ada 120 Blanco. Mirror Serie 1 120 x 60.

medida cm	nºpzax/box	m²/box	kg/box	boxes/pallet	m²/pallet	kg/pallet
30x60	7	1,26	18,64	48	60,48	894,72

# KOTA 60 30X60 11<sup>13/16</sup>"X23<sup>5/8</sup>"



30 x 60 Kota\*  
Blanco **30K0407** (03-04)



30 x 60 Duri  
Blanco **30K0447** (03-06)



30 x 60 Yan\*  
Blanco **30K0427** (03-06)



30 x 60 Kota\*  
Beige **30K0707** (03-04)



30 x 60 Duri  
Beige **30K0747** (03-06)



30 x 60 Yan\*  
Beige **30K0727** (03-06)



30 x 60 Kota\*  
Gris **30K0307** (03-04)



30 x 60 Duri  
Gris **30K0347** (03-06)



30 x 60 Yan\*  
Gris **30K0327** (03-06)



30 x 60 Kota\*  
Negro **30K0907** (03-04)



30 x 60 Duri  
Negro **30K0947** (03-06)



30 x 60 Yan\*  
Negro **30K0927** (03-06)



III Revestimiento: Yan Negro 30 x 60.

# ESCORIAL 60X60 23<sup>5/8</sup>"X23<sup>5/8</sup>" 80X80 31<sup>1/2</sup>"X31<sup>1/2</sup>"

PORCELÁNICO  
PORCELAIN TILE

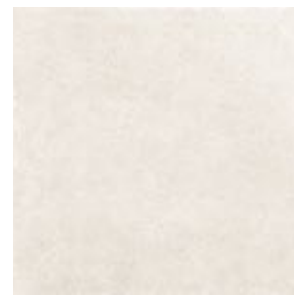

BLANCO

IV



BEIGE

IV



GRIS

IV



NEGRO

IV

(\*) Disponible 31,5x100  
Available 31,5x100  
Angebotene 31,5x100  
Disponibile 31,5x100  
Disponibili 31,5x100  
Dostępny 31,5x100



30 x 30 Musa Cristal Oro  
**69MU-CR** (40-75)



30 x 30 Musa Cristal Plata  
**69MU-CP** (40-75)

medida cm	nºpzax/box	m²/box	kg/box	boxes/pallet	m²/pallet	kg/pallet
30x60	7	1,26	18,64	40	60,48	745,60



# LANDART 60 30X60 11<sup>13/16</sup>"X23<sup>5/8</sup>"

NUEVO NEW



30 x 60 Landart\*  
Blanco **37LD407** (03-04)



30 x 60 Basket\*  
Blanco **37LD417** (03-06)



30 x 60 Square  
Blanco **30LD447** (03-06)

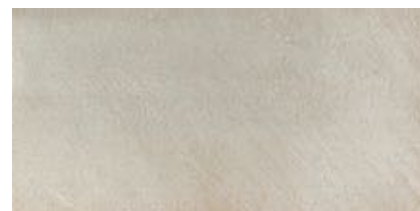

30 x 60 Landart\*  
Gris **37LD307** (03-04)



30 x 60 Basket\*  
Gris **37LD317** (03-06)



30 x 60 Square  
Gris **30LD347** (03-06)

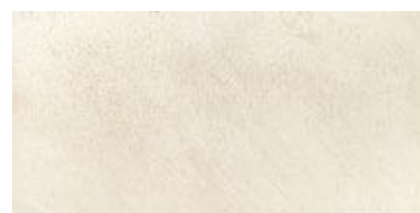

30 x 60 Landart\*  
Beige **37LD707** (03-04)



30 x 60 Basket\*  
Beige **37LD717** (03-06)



30 x 60 Square  
Beige **30LD747** (03-06)

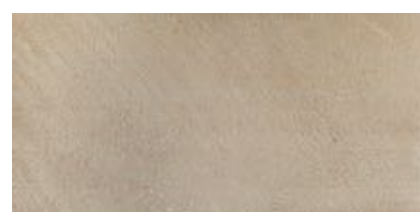

30 x 60 Landart\*  
Taupé **37LD207** (03-04)



30 x 60 Basket\*  
Taupé **37LD217**(03-06)



30 x 60 Square  
Taupé **30LD247** (03-06)



**COMBINA CON EL PAVIMENTO**  
MATCHES FLOOR TILES  
ASSORTIS AUX CARREAUX DE SOL  
PASST ZU DEN BODENFLIESEN  
SI ABBINA AL PAVIMENTO  
PROPONOWANE POŁĄCZENIE Z PŁYTKĄ PODŁOGOWĄ  
СОЧЕТАЕТСЯ С НАПОЛЬНЫМ ПОКРЫТИЕМ

GEA  
60X60 / 60X120 / 80X80

PÁG. 118

(\*) Disponible 31,5x100  
Available 31,5x100  
Angebotene 31,5x100  
Disponibile 31,5x100  
Disponibili 31,5x100  
Dostępny 31,5x100



30 x 30 Musa Cristal Oro  
**69MU-CR** (40-75)



30 x 30 Musa Cristal Plata  
**69MU-CP** (40-75)

medida cm	nºpzax/box	m²/box	kg/box	boxes/pallet	m²/pallet	kg/pallet
30x60	7	1,26	18,64	40	60,48	745,60
31,5x100	4	1,26	19,50	55	69,30	1.072,50





III Revestimiento: Lombardia Beige y Marrón 30 x 60, Monza Beige 20 x 60, Sami 6 Oro.  
Π Mueble: Moon Madera Café 80. Mirror Serie 3 80 x 60.

≡ Pavimento: Meteor Blanco 60x60.

## LOMBARDIA 30X60 11<sup>13/16</sup>"X23<sup>5/8</sup>"



30 X 60 Lombardia Beige **37L0707** (02-63) | 30 X 60 Lombardia Marrón **37L0007** (02-63) | 30 X 60 Lombardia Blanco **37L0407** (02-63) | 30 X 60 Lombardia Antracita **37L0607** (02-63) | 30 X 60 Lombardia Perla **37L0807** (02-63) | 30 X 60 Lombardia Azul **37L0507** (02-63)



30 X 60 Garda Beige **17L0736** (13-81) | Blanco **17L0436** (13-81) | 7,5 x 60 Como Marrón **16L006C** (13-82) | 7,5 x 60 Como Blanco **16L046C** (13-82) | 20 x 60 Monza Blanco **75L040M** (03-30) | Beige **75L070M** (03-30) | 1,5 x 60 Sami 6 Acero **160L36S** (13-76) | Oro **160L26S** (13-76)

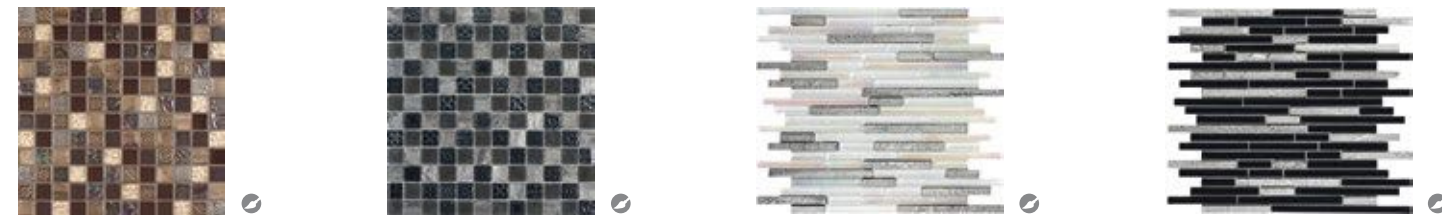

30 x 30 Musa Bronce **69MU-BR** (40-40) | 30 x 30 Musa Oceano **69MU-OC** (40-40) | 30 x 30 Musa Rectangular Blanco **69MU-RB** (40-40) | 30 x 30 Musa Rectangular Negro **69MU-RN** (40-40)



III Revestimiento: Lombardia Blanco 30 x 60, Garda Blanco 30 x 60.

□ Mueble: Ada 60 Blanco. Miror Serie 1 50 x 80.

## MILÁN 45X45 17<sup>3/4</sup>"X17<sup>3/4</sup>"



Blanco **42MN-48** (07-70) IV | Antracita **42MN-68** (07-70) III | Perla **42MN-88** (07-70) IV



Azul **42MN-58** (07-70) III | Beige **42MN-78** (07-70) IV | Marrón **42MN-08** (07-70) III

PORCELÁNICO  
PORCELAIN TILE

medida cm	nºpzax/box	m²/box	kg/box	boxes/pallet	m²/pallet	kg/pallet
30x60	7	1,26	18,64	48	60,48	894,72
45x45 pavimento	5	1,01	23,30	66	66,66	824,00



MARITIMA 30X60 11<sup>13/16</sup>"X23<sup>5/8</sup>"



30 x 60 Báltico  
Blanco 30BT47R (03-12)



30 x 60 Egeo  
Blanco 30EE47R (03-12)



30 x 60 Barents  
Blanco 30BR47R (03-12)



30 x 60 Barents  
Beige 30BR77R (03-12)



30 x 60 Balear  
Blanco 30BT40T (03-13)



30 x 60 Luminor  
17BT93L (13-30)

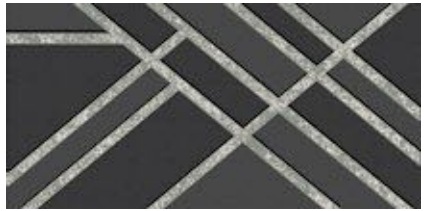

30 x 60 Platinum (set de 2 piezas)  
17BT93P (13-81)



30 x 60 Urano (set de 2 piezas)  
17BT93U (13-77)



NUEVO NEW

III Revestimiento: Egeo Blanco 30 x 60, Platinum 30 x 60. PAVIMENTO: Avenue Negro 60x60 y 15x15.



Balear

medida cm	nºpzax/box	m²/box	kg/box	boxes/pallet	m²/pallet	kg/pallet
30x60	7	1,26	18,64	40	60,48	745,60



# MATERIA 30X60 11 13/16" X 23 5/8"



30 x 60 Materia  
37MT407 (03-29)



3 x 30 Kavala  
Marrón 16CI01K (12-91)



1,5 x 60 Sami 6  
Acero 16OL36S (13-76)



3 x 30 Kavala  
Negro 16CI61K (12-91)

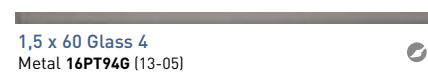

1,5 x 60 Glass 4  
Metal 16PT94G (13-05)



30 x 30 Ethosa  
Negro 41NB90E (13-05)



30 x 30 Amadora  
Antracita 41SI50A (13-05)

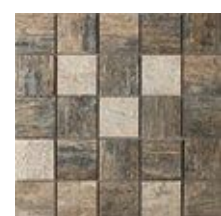

30x30 Reserva  
Bobal 41CV10R (09-05)



30x30 Saona  
Galena 41LY50S (13-71)



30 x 30 Musa  
Rectangular Negro  
69MU-RN (40-40)



30 x 30 Musa  
Rectangular Blanco  
69MU-RB (40-40)



30 x 30 Musa  
Rectangular Marrón  
69MU-RM (40-40)



30 x 30 Musa  
Bronce  
69MU-BR (40-40)

## COMBINA CON EL PAVIMENTO

MATCHES FLOOR TILES  
ASSORTIS AUX CARREAUX DE SOL  
PASST ZU DEN BODENFLIESEN  
SI ABBINA AL PAVIMENTO  
PROPONOWANE POŁĄCZENIE Z PŁYTKA PODŁOGOWA  
СОЧЕТАЕТСЯ С НАПОЛНЫМ ПОКРЫТИЕМ

## MULTIFORMATO

CANAIMA PÁG.106  
ESTAMPA PÁG.124  
METEOR PÁG.044



III Revestimiento: Materia 30 X 60.

medida cm	nºpzax/box	m²/box	kg/box	boxes/pallet	m²/pallet	kg/pallet
30x60	7	1,26	18,64	48	60,48	894,72



# WABI SABI 30X60 11<sup>13/16</sup>"X23<sup>5/8</sup>"



30 x 60 Wabi Concrete  
Blanco **30WC407** (03-04)



30 x 60 Wabi Fabric  
Blanco **30WF407** (03-04)



30 x 60 Wabi Wood  
Blanco **30WW407** (03-05)



30 x 60 Wabi Concrete  
Beige **30WC707** (03-04)



30 x 60 Wabi Fabric  
Beige **30WF707** (03-04)



30 x 60 Wabi Wood  
Beige **30WW707** (03-05)



30 x 60 Wabi Concrete  
Gris **30WC307** (03-04)



30 x 60 Wabi Fabric  
Gris **30WF307** (03-04)



30 x 60 Wabi Wood  
Gris **30WW307** (03-05)

# WABI SABI 60X60 23<sup>5/8</sup>"X23<sup>5/8</sup>"

PORCELÁNICO  
PORCELAIN TILE



60 x 60 Wabi Concrete  
Blanco **52WC45R** (07-82)



60 x 60 Wabi Concrete  
Beige **52WC75R** (07-82)



60 x 60 Wabi Concrete  
Gris **52WC35R** (07-82)



Wabi Fabric  
Wabi Wood  
30X60

Wabi concrete  
60x60



Wabi concrete  
60x60



R10  
C2

Wabi concrete  
60x60



medio

medida cm	nºpzax/box	m²/box	kg/box	boxes/pallet	m²/pallet	kg/pallet
30x60	7	1,26	18,64	40	60,48	745,60

# JAVA 25X75 9<sup>7</sup>/<sub>8</sub>"X29<sup>9</sup>/<sub>16</sub>"

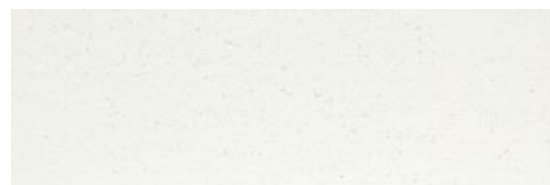

25 x 75 Java  
Blanco **67JA400** (04-05)



25 x 75 Java  
Beige **67JA700** (04-05)



25 x 75 Ceilan  
Blanco **17JA40C** (13-96)



25 x 75 Ceilan  
Beige **17JA70C** (13-96)



25 x 75 Mindanao  
Platino **17JA40M** (13-96)



25 x 75 Mindanao  
Oro **17JA70M** (13-96)



30 x 30 Musa  
Oceano  
**69MU-OC** (40-40)



30 x 30 Musa  
Bronce  
**69MU-BR** (40-40)



25 x 75 Java  
Gris **67JA300** (04-05)



25 x 75 Java  
Tabaco **67JA200** (04-05)



25 x 75 Ceilan  
Gris **17JA30C** (13-96)



25 x 75 Ceilan  
Tabaco **17JA20C** (13-96)



25 x 75 Borneo  
Blanco **17JA40B** (13-80)



25 x 75 Borneo  
Beige **17JA70B** (13-80)

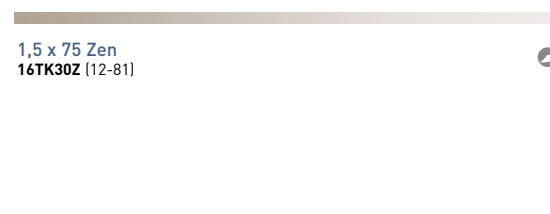

1,5 x 75 Zen  
**16TK30Z** (12-81)

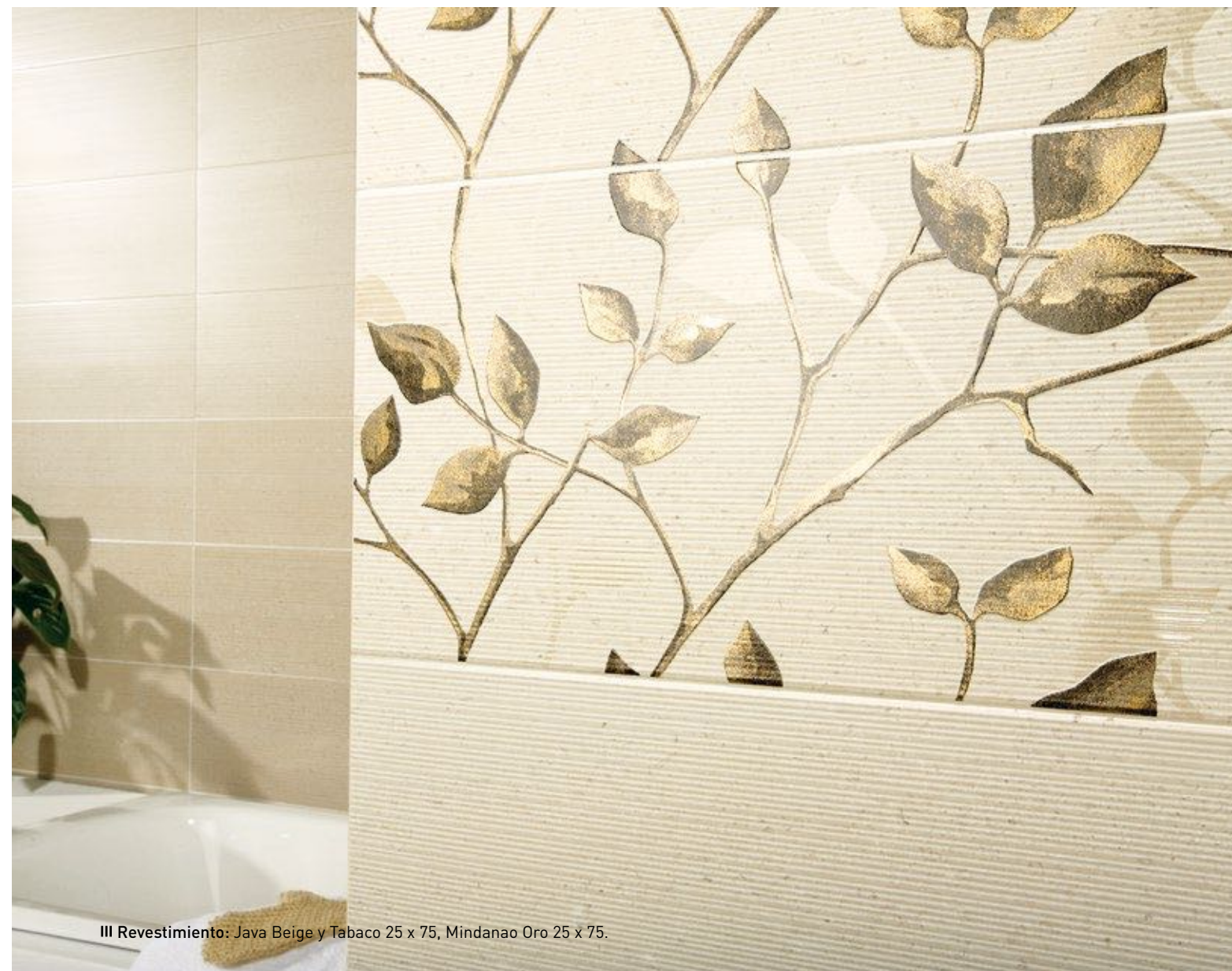

III Revestimiento: Java Beige y Tabaco 25 x 75, Mindanao Oro 25 x 75.

# NEPAL 45 45X45 17<sup>3</sup>/<sub>4</sub>"X17<sup>3</sup>/<sub>4</sub>"

PORCELÁNICO  
PORCELAIN TILE



Blanco **42NP-48** (07-70)

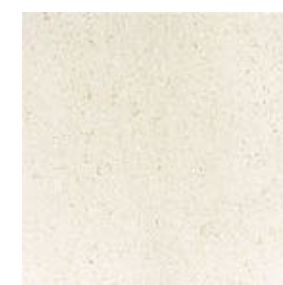

Beige **42NP-78** (07-70)



Tabaco **42NP-28** (07-70)



Gris **42NP-38** (07-70)

medida cm	nºpzax/box	m²/box	kg/box	boxes/pallet	m²/pallet	kg/pallet
25x75	8	1,50	21,90	48	72	1.051,20
45x45 pavimento	5	1,01	23,30	66	66,66	824,00

## MISTRAL 25X75 9<sup>7</sup>/<sub>8</sub>"X29<sup>9</sup>/<sub>16</sub>"

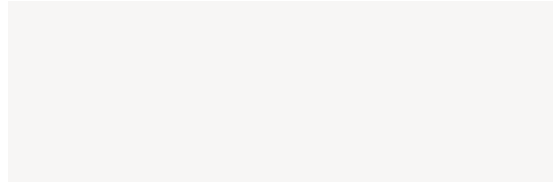

25 x 75 Mistral  
Blanco **67MI400** (00-63)



25 x 75 Brisa  
Blanco **67MI410** (04-22)



25 x 75 Brisa  
Malva **67MI910** (04-22)



25 x 75 Brisa  
Gris **67MI310** (04-22)



25 x 75 Osaka  
Blanco **77MI420** (04-22)



25 x 75 Boreas  
Blanco **67BO400** (04-05)



25 x 75 Brisa  
Naranja **67MI810** (04-22)



25 x 75 Brisa  
Amatista **67MI010** (04-22)



25 x 75 Brisa  
Antracita **67MI610** (04-22)



25 x 75 Sonora  
**17MI305** (18-00)



1,5 x 75 Zen  
**16TK30Z** (12-81)

## JOLLY 30X30 11<sup>13</sup>/<sub>16</sub>"X11<sup>13</sup>/<sub>16</sub>"

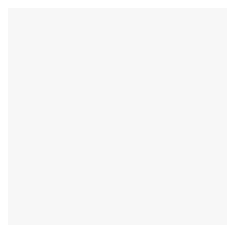

Blanco **35JO-46** (00-80)



Amatista **35JO-D6** (00-80)

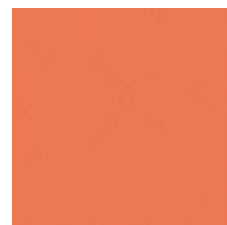

Tango **35JOTA6** (00-80)



Antracita **35JO-96** (00-80)

PAVIMENTO  
FLOOR TILES

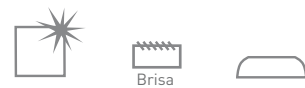

III Revestimiento: Mistral Blanco 25 x 75, Brisa Blanco y Malva 25 x 75, Solano Amatista 25 x 75  
 ≡ Pavimento: Jolly Amatista 30 x 30.  
 □ Mueble: Planet Blanco 60. Mirror Serie 4 Blanco

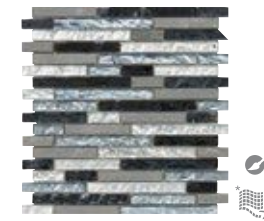

30 x 30 Musa Rectangular  
Gris  
**69MU-RG** (40-40)



30 x 30 Musa Brick  
Sandal  
**69MUBSA** (40-40)



30 x 30 Musa  
Brick Emperador  
**69MUBEM** (40-40)



30 x 30 Musa  
Bronce  
**69MU-BR** (40-40)

medida cm	nºpzax/box	m²/box	kg/box	boxes/pallet	m²/pallet	kg/pallet
25x75	8	1,50	21,90	48	72	1.051,20
30x30	11	1,00	17,20	64	64,00	1.100,80

SIROCO 25X75 9<sup>7</sup>/<sub>8</sub>"X29<sup>9</sup>/<sub>16</sub>"



# SIROCO 25X75 9<sup>7</sup>/<sub>8</sub>"X29<sup>9</sup>/<sub>16</sub>"

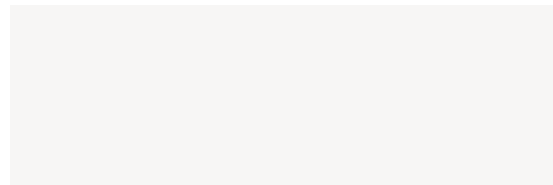

25 x 75 Siroco  
Blanco **67SI400** (00-93)



25 x 75 Siroco  
Negro **67SI9 00** (00-93)



25 x 75 Mar  
Blanco **67SI410** (04-13)



25 x 75 Mar  
Negro **67SI910** (04-13)



25 x 75 Cefiro  
Blanco **67CE400** (00-93)



25 x 75 Cefiro  
Negro **67CE600** (00-93)



25 x 75 Valira  
Blanco **67VA400** (00-93)



25 x 75 Valira  
Negro **67VA900** (00-93)



25 x 75 Veleta  
Blanco **67SI440** (04-22)



25 x 75 Veleta  
Negro **67SI990** (04-22)

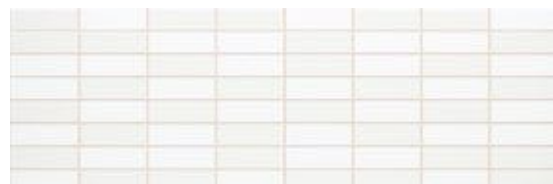

25 x 75 Alisio  
Blanco **67SI420** (04-22)



25 x 75 Alisio  
Negro **67SI920** (04-22)

# MELTEMI 30X60 11<sup>13</sup>/<sub>16</sub>"X23<sup>5</sup>/<sub>8</sub>"

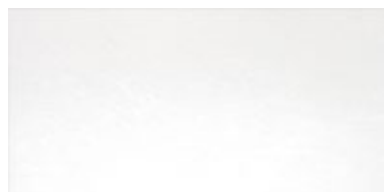

30 x 60 Meltemi  
Blanco **46SR-42** (07-81)



30 x 60 Meltemi  
Negro **46SR-92** (07-81)

PORCELÁNICO  
PORCELAIN TILE



1,5 x 75 Zen  
**16TK30Z** (12-81)



25 x 75 Helios  
Negro **17SI90E** (13-95)



25 x 75 Helios  
Blanco **17SI40E** (13-95)



25 x 75 Viento  
Negro **17SI90V** (13-82)



25 x 75 Viento  
Blanco **17SI40V** (13-82)



30 x 30 Musa Rectangular  
Gris  
**69MU-RG** (40-40)



30 x 30 Musa Brick  
Sandal  
**69MUBSA** (40-40)



30 x 30 Musa  
Carrara  
**69MU-CA** (40-40)

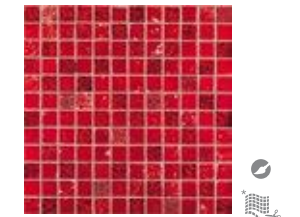

30 x 30 Musa  
Rojo  
**69MU-RO** (40-40)

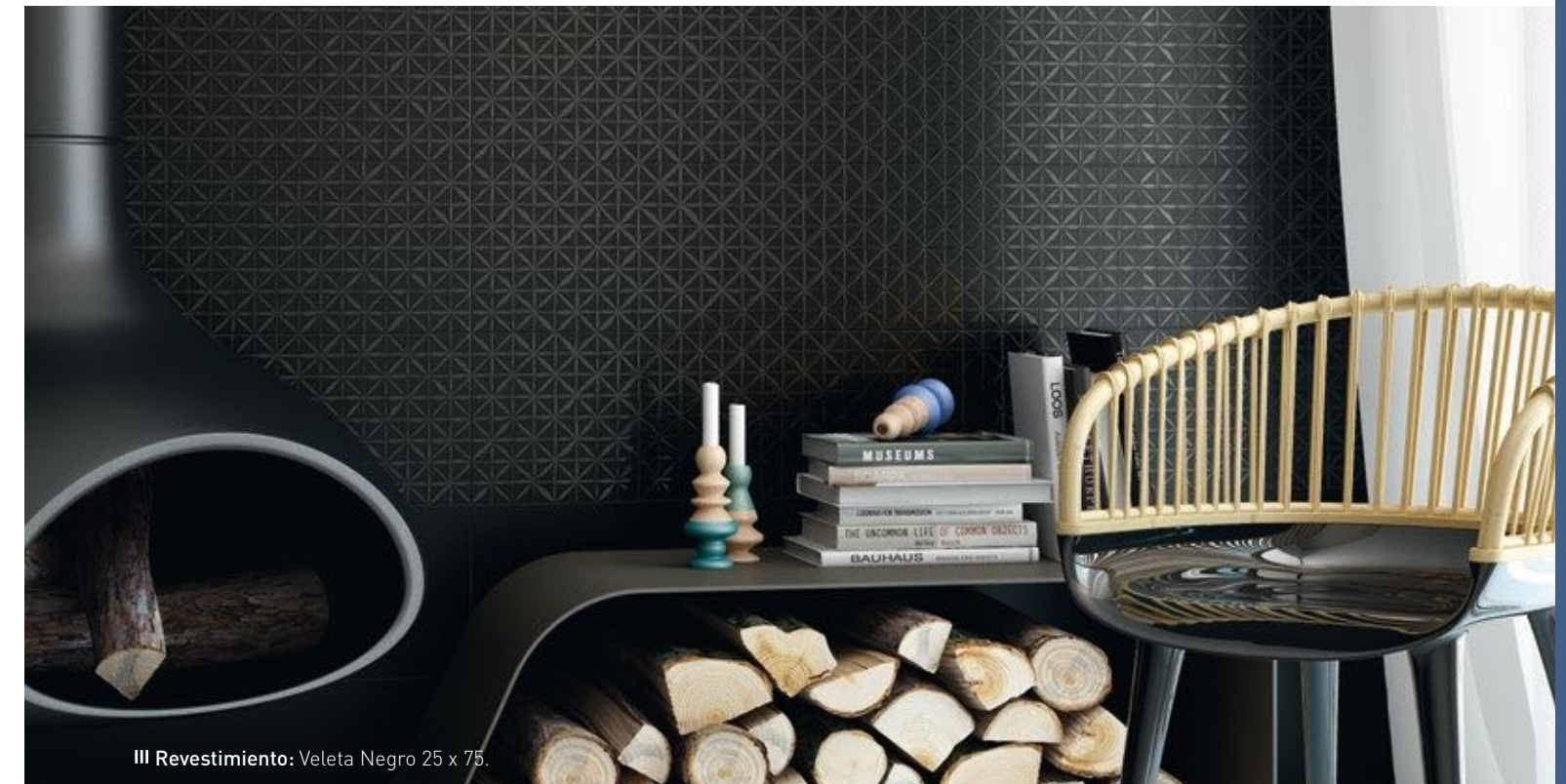

III Revestimiento: Veleta Negro 25 x 75.

medida cm	nºpzax/box	m²/box	kg/box	boxes/pallet	m²/pallet	kg/pallet
25x75	8	1,50	21,90	48	72	1.051,20
30X60	6	1,08	25,80	40	43,20	1.032,00

## BOSTON 25 25X40 9<sup>7</sup>/<sub>8</sub>"X15<sup>6</sup>/<sub>8</sub>"

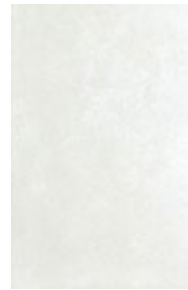

25 x 40 Boston 25  
Blanco **15BS405** (01-30)



25 x 40 Boston 25  
Cemento **15BS105** (01-30)



25 x 40 Boston 25  
Gris **15BS305** (01-30)



25 x 40 Boston 25  
Beige **15BS705** (01-30)



25 x 40 Boston 25  
Antracita **15BS605** (01-30)



25 x 40 Newton  
Blanco **15BS415** (01-40)



25 x 40 Newton  
Cemento **15BS115** (01-40)



25 x 40 Newton  
Gris **15BS315** (01-40)



25 x 40 Newton  
Beige **15BS715** (01-40)



25 x 40 Newton  
Antracita **15BS615** (01-40)



25 x 40 Clío  
Blanco **15BS425** (01-40)



25 x 40 Clío  
Gris **15BS325** (01-40)

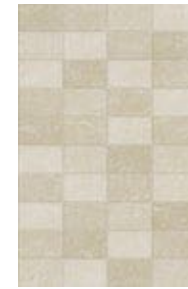

25 x 40 Clío  
Beige **15BS725** (01-40)

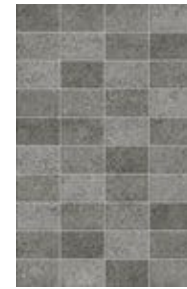

25 x 40 Clío  
Antracita **15BS625** (01-40)



25 x 40 Newport \*  
**15BS335** (01-40)

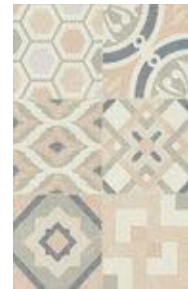

(\*) 4 gráficas diferentes empaquetadas aleatoriamente en cajas de 12 piezas.  
4 different patterns randomly selected and packed in boxes containing 12 pieces.  
4 verschiedene Grafiken, aleatorisch verpackt mit 12 Stück pro Karton.  
4 graphiques différents, empaquetés par cartons de 12 pièces de façon aléatoire.  
4 pezzi diversi, confezionati casualmente in scatole da 12 pezzi cadauna.  
4 verschillende patronen, willekeurig geselecteerd en verpakt in dozen van 12 stuks  
4 różne wzory powierzchni wybierane losowo i zapakowane w pudełka zawierające 12 sztuk.  
4 различных графических рисунков, упакованных путем случайного выбора по 12 штук в коробке.

## BOSTON 45X45 17<sup>3</sup>/<sub>4</sub>"X17<sup>3</sup>/<sub>4</sub>"

PORCELÁNICO  
PORCELAIN TILE



45 x 45 Boston  
Blanco **42B0-48** (07-60)

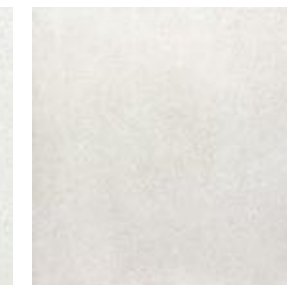

45 x 45 Boston  
Gris **42B0-38** (07-60)



45 x 45 Boston  
Cemento **42B0-18** (07-60)



45 x 45 Boston  
Antracita **42B0-68** (07-60)



45 x 45 Boston  
Beige **42B0-78** (07-60)



Newton



III Revestimiento: Boston Blanco 25 x 40, Newton Blanco 25 x 40, Newport 25 x 40.

III Pavimento: Boston Blanco 45 x 45.

medida cm	nºpzax/box	m²/box	kg/box	boxes/pallet	m²/pallet	kg/pallet
25x40	12	1,20	17,50	54	64,80	945,00
45x45 pavimento	5	1,01	23,30	66	66,66	824,00

CANADÁ / NEVADA 25X40 9<sup>7</sup>/<sub>8</sub>"X15<sup>6</sup>/<sub>8</sub>"

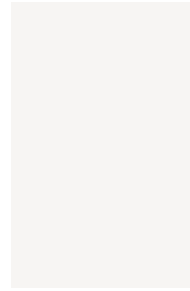

25 x 40 Canadá  
Blanco **15CN405** (07-36)

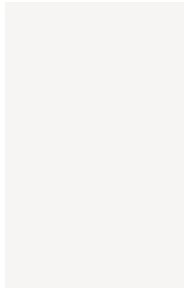

25 x 40 Nevada  
Blanco **15NV405** (07-36)

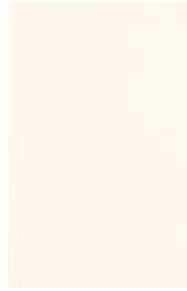

25 x 40 Nevada  
Beige **15NV705** (07-36)



25 x 40 Ottawa  
Blanco **15CN415** (01-50)



30 x 30 Musa  
Ferro  
**69MU-FE** (40-40)

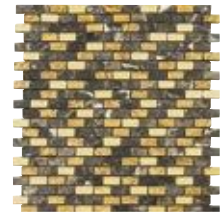

30 x 30 Musa Brick  
Emperador  
**69MUBEM** (40-40)



30 x 30 Ethosa  
Negro **41NB90E** (13-05)



30 x 30 Musa  
Rectangular Marrón  
**69MU-RM** (40-40)



30x30 Saona  
Galena **41LY50S** (13-71)



III Revestimiento: Ottawa Blanco 25 x 40.

□ Mueble: Ada 120 Antracita.

medida cm	nºpzax/box	m²/box	kg/box	boxes/pallet	m²/pallet	kg/pallet
25x40	12	1,20	17,50	54	64,80	945,00



# COLUMBIA 25 25X40 9<sup>7</sup>/<sub>8</sub>"X15<sup>6</sup>/<sub>8</sub>"

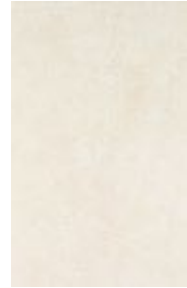

25 x 40 Columbia 25  
Beige **15CL705** (07-46)



25 x 40 Jasper  
Marrón **17CL03J** (13-60)  
Antracita **17CL63J** (13-60)



25 x 40 Columbia 25  
Marrón **15CL005** (07-46)



25 x 40 Fraser  
Marrón **17CL03F** (13-15)  
Beige **17CL73F** (13-15)  
Blanco **17CL43F** (13-15)  
Gris **17CL33F** (13-15)  
Antracita **17CL63F** (13-15)



25 x 40 Columbia 25  
Blanco **15CL405** (07-46)



25 x 40 Columbia 25  
Gris **15CL305** (07-46)



25 x 40 Vernon  
Blanco **15CL415** (07-62)  
Beige **15CL715** (07-62)



25 x 40 Columbia 25  
Antracita **15CL605** (07-46)

**COMBINA CON EL PAVIMENTO**  
MATCHES FLOOR TILES  
ASSORTIS AUX CARREAUX DE SOL  
PASST ZU DEN BODENFLIESEN  
SI ABBINA AL PAVIMENTO  
PROPONOWANE POŁĄCZENIE Z PŁYTKĄ PODŁOGOWĄ  
СОЧЕТАЕТСЯ С НАПОЛЬНЫМ ПОКРЫТИЕМ

**COLUMBIA 45**  
Blanco, Gris, Antracita,  
Beige, Marrón.

PÁG. 282



III Revestimiento: Vernon Beige 25 x 40.

medida cm	nºpzax/box	m²/box	kg/box	boxes/pallet	m²/pallet	kg/pallet
25x40	12	1,20	17,50	54	64,80	945,00
45x45 pavimento	5	1,01	23,30	66	66,66	824,00



## REIMS 25X40 9<sup>7/8</sup>"X15<sup>6/8</sup>"



25x40 Reims  
Blanco **15RE405** (01-30)

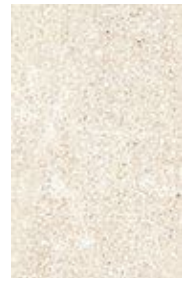

25x40 Reims  
Marfil **15RE705** (01-30)



25x40 Reims  
Gris **15RE305** (01-30)



25x40 Nimes  
Blanco **15RE445** (01-30)



25x40 Nimes  
Marfil **15RE745** (01-30)



25x40 Nimes  
Gris **15RE345** (01-30)



25x40 Beziers  
Blanco **15RE415** (01-30)



25x40 Beziers  
Marfil **15RE715** (01-30)



25x40 Beziers  
Gris **15RE315** (01-30)



25x40 Narbonne  
Blanco **15RE435** (01-40)



25x40 Narbonne  
Marfil **15RE735** (01-40)



25x40 Narbonne  
Gris **15RE335** (01-40)



25x40 Vesla  
**15RE755** (01-40)

## REIMS 30X30 11<sup>13/16</sup>"X11<sup>13/16</sup>"



30x30 Reims  
Blanco **40RE-40** (01-35)



30x30 Reims  
Marfil **40RE-70** (01-35)



30x30 Reims  
Gris **40RE-30** (01-35)

PORCELÁNICO  
PORCELAIN TILE



30x30



30x30  
25x40



8 mm (25x40)



9 mm (30x30)



30x30



alto



30x30



III Revestimiento: Reims 25 Blanco 25x40, Beziers Blanco 25x40.

medida cm	nºpzax/box	m <sup>2</sup> /box	kg/box	boxes/pallet	m <sup>2</sup> /pallet	kg/pallet
25x40	12	1,20	17,50	54	64,80	945,00
30x30 pavimento	10	0,90	20,70	48	43,20	993,00

# ATACAMA 20x60 7<sup>7</sup>/<sub>8</sub>"x23<sup>5</sup>/<sub>8</sub>"

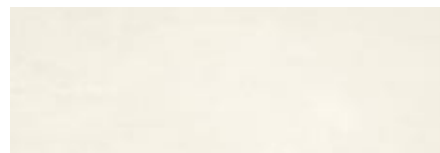

20x60 Atacama  
Nieve **75AT000** (01-41)



20x60 Atacama  
Blanco **75AT400** (01-41)



20x60 Atacama  
Beige **75AT700** (01-41)



20x60 Atacama  
Tabaco **75AT200** (01-41)



20x60 Atacama  
Gris **75AT300** (01-41)



20x60 Atacama  
Marengo **75AT500** (01-41)



20x60 Atacama  
Negro **75AT900** (01-41)



14,3x60 Bariloche  
Negro **16AT96L** (13-76)  
Marrón **16AT26L** (13-76)

1,5 x 60 Sami 6  
Acero **160L365** (13-76)



20x33,3 Viedma  
Nieve **24AT00V** (03-15)  
Marfil **24AT70V** (03-15)  
Marrón **24AT20V** (03-15)  
Negro **24AT90V** (03-15)

### COMBINA CON EL PAVIMENTO

MATCHES FLOOR TILES  
ASSORTIS AUX CARREAUX DE SOL  
PASST ZU DEN BODENFLIESEN  
SI ABBINA AL PAVIMENTO  
PROPONOWANE POLACZENIE Z PLYTKA PODLOGOWA  
СОЧЕТАЕТСЯ С НАПОЛЬНЫМ ПОКРЫТИЕМ

### MULTIFORMATO

ATACAMA  
Blanco, Gris, Marengo,  
Negro, Beige, Tabaco  
PÁG.032



III Revestimiento: Atacama Tabaco y Blanco 20x60, Viedma Marfil 20 x 33,3.

≡ Pavimento: Atacama Tabaco 60x60, Paine Tabaco 30 x 30.

medida cm	nºpzax/box	m²/box	kg/box	boxes/pallet	m²/pallet	kg/pallet
20x60	9	1,08	20,00	48	51,84	960,00

# NEBRASKA 20X60 7<sup>7</sup>/<sub>8</sub>"X23<sup>5</sup>/<sub>8</sub>"



20 x 60 Nebraska  
Blanco 75NE400 (01-41)



20 x 60 Nebraska  
Negro 75NE900 (01-41)



20 x 60 Fremont  
Blanco 17NE43F (13-73)



20 x 60 Fremont  
Negro 17NE93F (13-73)



1,5 x 60 Sami 6  
Acero 160L36S (13-76)



20 x 60 Valentine\*  
75NE990 (03-10)



30 x 30 Musa Fossil  
Antracita 69MU-FA (40-40)



30,9 x 31,1 Musa Klimt  
Antracita 69MU-KA (40-60)

[\*] 2 gráficas diferentes empaquetadas aleatoriamente en cajas de 9 piezas.  
2 different patterns randomly selected and packed in boxes containing 9 pieces.  
2 verschiedene Grafiken, aleatorisch verpackt mit 9 Stück pro Karton.  
2 graphiques différents, empaquetés par cartons de 9 pièces de façon aléatoire.  
2 pezzi diversi, confezionati casualmente in scatole da 9 pezzi cadauna.  
2 verschillende patronen, willekeurig geselecteerd en verpakt in dozen van 9 stuks  
2 różne wzory powierzchni wybierane losowo i zapakowane w pudełka zawierające 9 sztuk.  
2 различных графических рисунков, упакованных путем случайного выбора по 9 штук в коробке.

**COMBINA CON EL PAVIMENTO**  
MATCHES FLOOR TILES  
ASSORTIS AUX CARREAUX DE SOL  
PASST ZU DEN BODENFLIESEN  
SI ABBINA AL PAVIMENTO  
PROPONOWANE POŁĄCZENIE Z PŁYTKĄ PODŁOGOWĄ  
СОЧЕТАЕТСЯ С НАПОЛЬНЫМ ПОКРЫТИЕМ

ALPES  
Negro  
MELTEMI  
Negro

PÁG.030  
PÁG.312



III Revestimiento: Nebraska Negro 20 x 60, Fremont Negro 20 x 60, Valentine 20 x 60. ≡ Pavimento: Patagonia Encina 19,5 x 120.

medida cm	nºpzax/box	m²/box	kg/box	boxes/pallet	m²/pallet	kg/pallet
20x60 relieve	9	1,08	20,00	48	51,84	960,00



MOSAICO  
MOSAIC

MOSAÏQUES  
MOSAIKE  
MOSAICI  
MOZAIKI  
MOZAÏEK  
МОЗАИКА



**32,7X32,7** 12<sup>7/8</sup>" X 12<sup>7/8</sup>"

CIRENE	328
SIGNIA	332
VELIA	333

**30X30** 11<sup>13/16</sup>" X 11<sup>13/16</sup>"

MUSA	330
------	-----

CIRENE 32,7X32,7 12<sup>7/8</sup>"X12<sup>7/8</sup>"



32,7 x 32,7 Cirene  
Cuarzo  
69CI-CU (40-10)

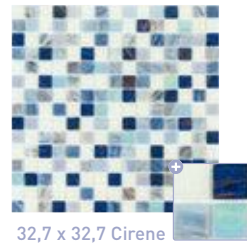

32,7 x 32,7 Cirene  
Cielo  
69CI-CI (40-10)

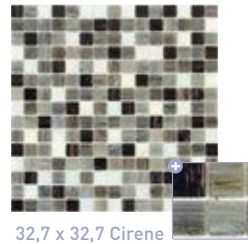

32,7 x 32,7 Cirene  
Gris  
69CI-GR (40-10)

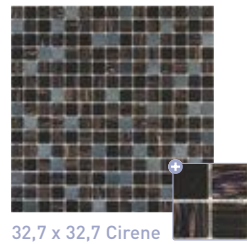

32,7 x 32,7 Cirene  
Onix  
69CI-ON (40-10)

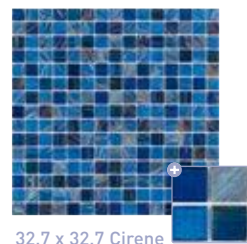

32,7 x 32,7 Cirene  
Azul  
69CI-AZ (40-10)

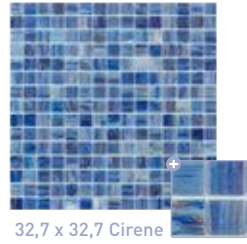

32,7 x 32,7 Cirene  
Celeste  
69CI-CL (40-10)



32,7 x 32,7 Cirene  
Turquesa  
69CI-TU (40-10)



32,7 x 32,7 Cirene  
Verde  
69CI-VE (40-10)



32,7 x 32,7 Cirene  
Rosa  
69CI-RO (40-70)

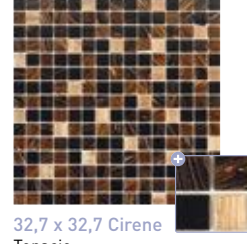

32,7 x 32,7 Cirene  
Topacio  
69CI-TO (40-10)



32,7 x 32,7 Cirene  
Ambar  
69CI-AM (40-10)

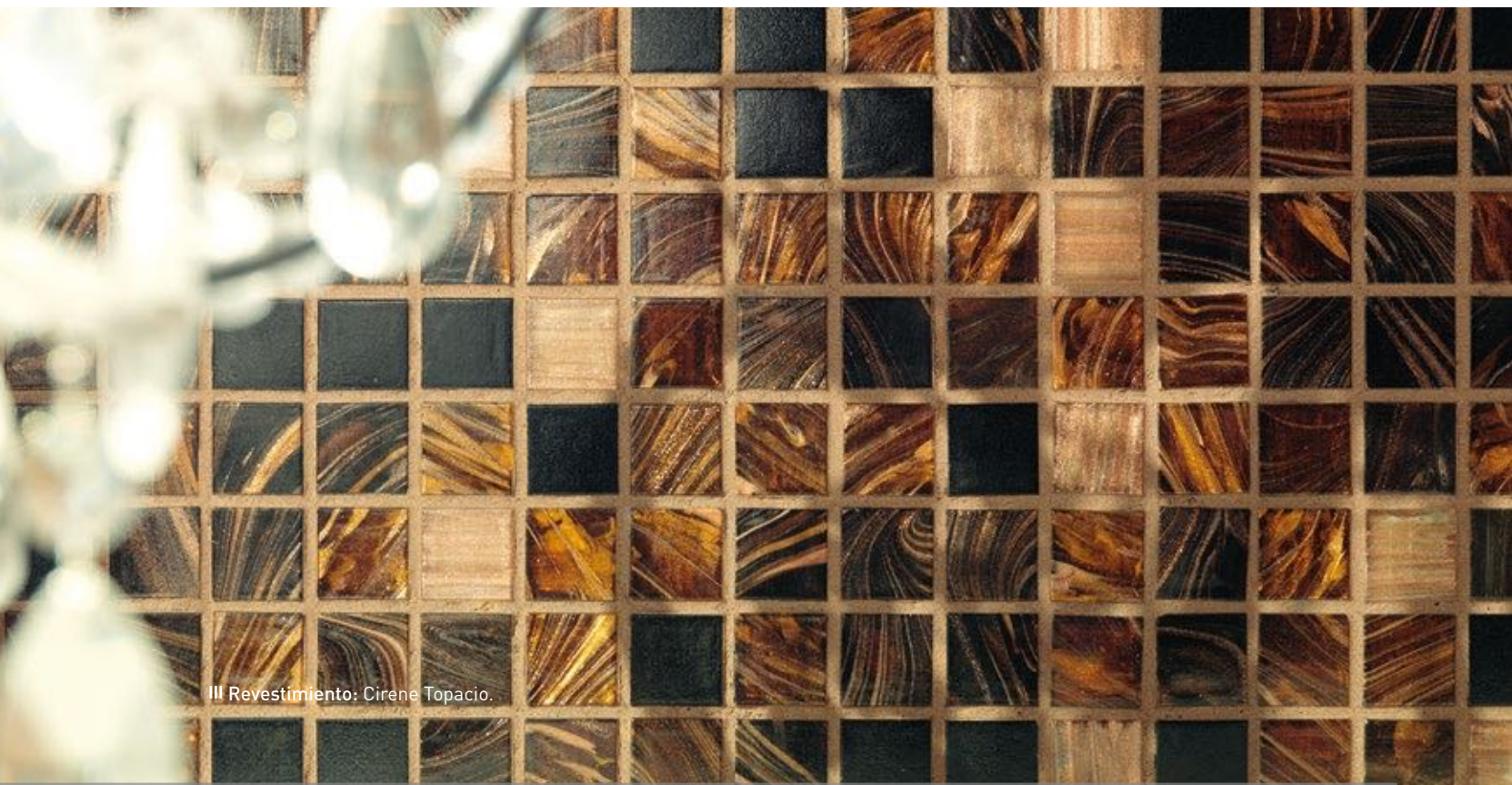

III Revestimiento: Cirene Topacio.



III Revestimiento: Cirene Rosa





30 x 30 Musa Carrara  
69MU-CA (40-40)



30 x 30 Musa Damascado  
69MU-DA (40-40)



30 x 30 Musa Silver  
69MU-SI (40-40)



30 x 30 Musa Cobre  
69MU-CO (40-60)

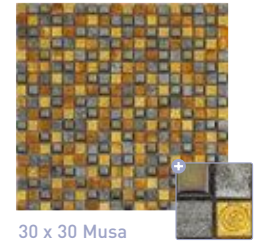

30 x 30 Musa Ambar  
69MU-AM (40-40)



30 x 30 Musa Marquina  
69MU-MA (40-40)



30,9 x 31,1 Musa Klimt Marrón  
69MU-KM (40-60)

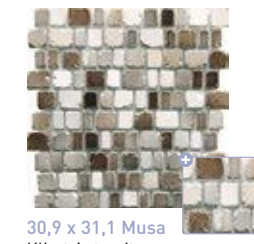

30,9 x 31,1 Musa Klimt Antracita  
69MU-KA (40-60)



30 x 30 Musa Fossil Beige  
69MU-FB (40-40)



30 x 30 Musa Fossil Antracita  
69MU-FA (40-40)



30 x 30 Musa Titanio  
69MU-TI (40-40)

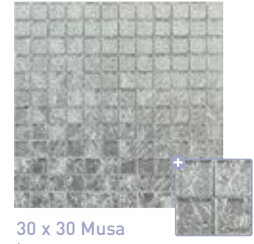

30 x 30 Musa Luna  
69MU-LU (40-60)

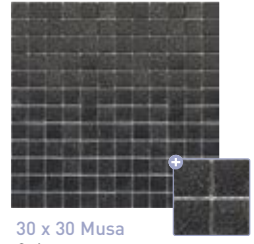

30 x 30 Musa Onix  
69MU-ON (40-60)



32,7 x 32,7 Musa Gold  
69MU-GO (40-80)



30 x 30 Musa Oceano  
69MU-OC (40-40)

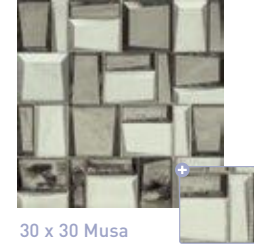

30 x 30 Musa Cristal Plata  
69MU-CP (40-75)



30 x 30 Musa Cristal Oro  
69MU-CR (40-75)



30 x 30 Musa Ferro  
69MU-FE (40-40)



30 x 30 Musa Bronce  
69MU-BR (40-40)



30 x 30 Musa Rojo  
69MU-RO (40-40)



26,4 x 27,4 Musa Exagono Marrón  
69MU-EM (40-70)



26,4 x 27,4 Musa Exagono Negro  
69MU-EN (40-70)



30 x 30 Musa Brick Sandal  
69MUBSA (40-40)



30 x 30 Musa Brick Emperador  
69MUBEM (40-40)



30 x 30 Musa Brick Capuccino  
69MUBCA (40-40)

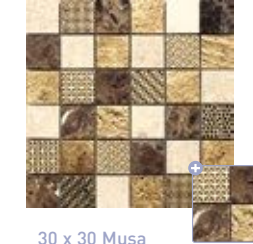

30 x 30 Musa Damasco Marrón  
69MU-DM (40-70)



30 x 30 Musa Damasco Negro  
69MU-DN (40-70)



30 x 30 Musa Rectangular Negro  
69MU-RN (40-40)



30 x 30 Musa Rectangular Gris  
69MU-RG (40-40)



30 x 30 Musa Rectangular Blanco  
69MU-RB (40-40)



30 x 30 Musa Rectangular Marrón  
69MU-RM (40-40)



III Revestimiento: Musa Bronce



**SIGNIA** 32,7X32,7 12<sup>7/8</sup>"X12<sup>7/8</sup>"

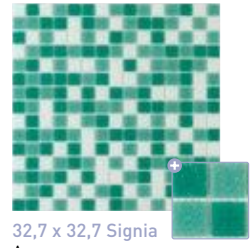

32,7 x 32,7 Signia  
Acqua  
69SI-AC (40-00)



32,7 x 32,7 Signia  
Verde  
69SI-VE (40-00)



32,7 x 32,7 Signia  
Azul  
69SI-AZ (40-00)

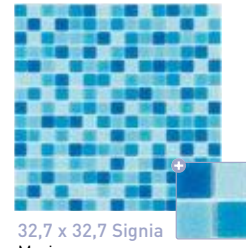

32,7 x 32,7 Signia  
Marino  
69SI-MA (40-00)

**VELIA** 32,7X32,7 12<sup>7/8</sup>"X12<sup>7/8</sup>"



32,7 x 32,7 Velia  
Cube Perla  
69VECP (40-10)

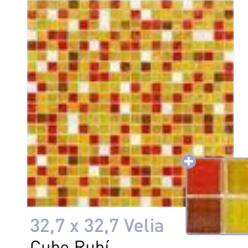

32,7 x 32,7 Velia  
Cube Rubí  
69VECR (40-10)



32,7 x 32,7 Velia  
Cube Miel  
69VECM (40-10)

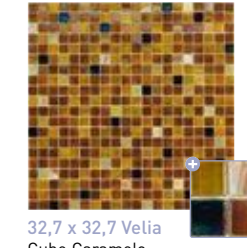

32,7 x 32,7 Velia  
Cube Caramelo  
69VECA (40-10)

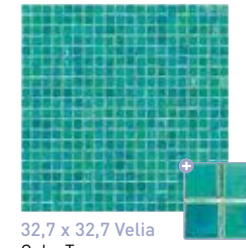

32,7 x 32,7 Velia  
Cube Turquesa  
69VECT (40-10)



III Revestimiento: Signia verde y Acqua.



III Revestimiento: Velia Cube Caramelo.





## MUEBLE BAÑO BATHROOM FURNITURE

MEUBLES DE SALLE DE BAINS  
BADMÖBEL  
ARREDAMENTO BAGNO  
MEBLE ŁAZIENKOWE  
BADKAMERMEUBELS  
МЕБЕЛЬ ДЛЯ ВАННЫХ КОМНАТ

ADA	336
AQUA	338
ASTER	342
MOON	344
PLANET	346
ESPEJOS / MIRRORS	348
CARACTERÍSTICAS TÉCNICAS TECHNICAL CHARACTERISTICS	350



# ADA 60 / 80 / 100 / 120

## MEDIDAS MUEBLE (MM) / UNIT DIMENSIONS / MESURES MEUBLE / MAßE SCHRANK / MISURE MOBILE / WYMIARY MEBLA / AFMETINGEN VAN DE MEUBELS / РАЗМЕРЫ МЕБЕЛИ

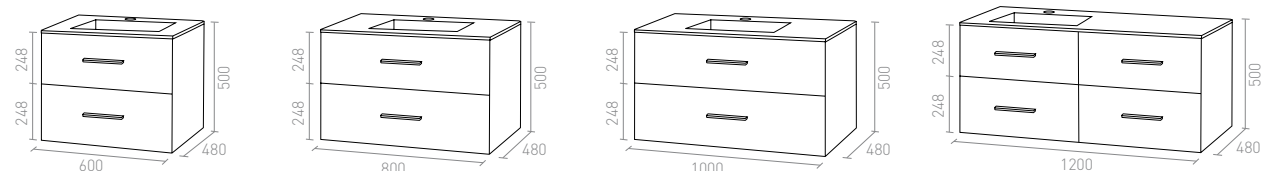

	Ada 60	Ada 80	Ada 100	Ada 120
BLANCO	<b>68A60BL</b>	<b>68A80BL</b>	<b>68A100BL</b>	<b>68A120BL</b>
ANTRACITA	<b>68A60AN</b>	<b>68A80AN</b>	<b>68A100AN</b>	<b>68A120AN</b>
ROJO	<b>68A60RO</b>	<b>68A80RO</b>	<b>68A100RO</b>	<b>68A120RO</b>

## ENCIMERAS / COUNTERS / PLANS DE TOILETTE / WASCHTISCHE / TOP / BLATY LAZIENKOWE / WERKBLADEN / СТОЛЕШНИЦЫ

Solid Surface (mm.)

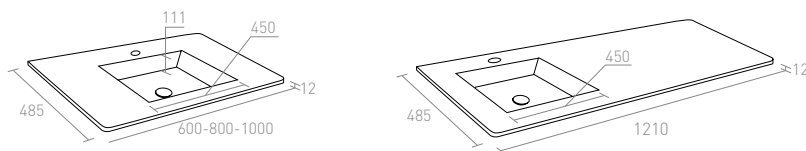

Solid Surface 60	<b>68E60R3</b>
Solid Surface 80	<b>68E80R3</b>
Solid Surface 100	<b>68E100R3</b>
Solid Surface 120	<b>68E120R3</b>

## MUEBLES AUXILIARES / BATHROOM CABINETS / MEUBLES D'APPOINT / EINZELMÖBEL / MOBILI AUSILIARI / MEBLE POMOCNICZE / AANVULLENDE MEUBELS / ВСПОМОГАТЕЛЬНЫЕ ПРЕДМЕТЫ МЕБЕЛИ

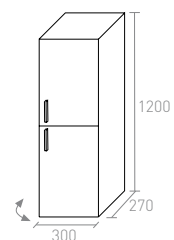

Tirador en el lado izquierdo.  
Apertura hacia la derecha.  
Handle on the left side.  
Opens to the right.  
Tirette sur le côté gauche.  
Ouverture vers la droite.  
Griff auf der linken Seite.  
Öffnung auf der rechten Seite.  
Maniglia sul lato sinistro.  
Apertura verso destra.  
Uchwyt z lewej strony.  
Otwierane na prawo.  
Handgreep aan de linkerkant.  
Opent naar rechts.  
Ручка с левой стороны.  
Открытие направо.

Columna Ada Blanco	<b>68CADBL</b>
Columna Ada Antracita	<b>68CADAN</b>
Columna Ada Rojo	<b>68CADRO</b>

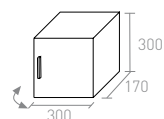

Tirador en el lado izquierdo.  
Apertura hacia la derecha.  
Handle on the left side.  
Opens to the right.  
Tirette sur le côté gauche.  
Ouverture vers la droite.  
Griff auf der linken Seite.  
Öffnung auf der rechten Seite.  
Maniglia sul lato sinistro.  
Apertura verso destra.  
Uchwyt z lewej strony.  
Otwierane na prawo.  
Handgreep aan de linkerkant.  
Opent naar rechts.  
Ручка с левой стороны.  
Открытие направо.

Cubo Ada Blanco	<b>68BADBL</b>
Cubo Ada Antracita	<b>68BADAN</b>
Cubo Ada Rojo	<b>68BADRO</b>

## COLORES Y ACABADOS / COLOURS AND FINISHES / COULEURS ET FINITION / FARBEN UND FINISHS / COLORI E FINITURE / KOLORY I WYKOŃCZENIA / KLEUREN EN AFWERKINGEN / ЦВЕТА И ОТДЕЛКИ

Lacado Brillo / Gloss Lacquer / Laqué Brillant / Glänzed lackiert / Laccato lucido / Lakierowane z połyskiem / Glans gelakt / Лакированный блестящий



Blanco

Antracita

Rojo



▣ Mueble: Ada 120 Antracita. Encimera Solid Surface 120. Mirror Serie 1 50 x 80.





□ Mueble: Aqua 120 seno izq. blanco. Encimera MineralMarmo seno izq. 120. Mueble cajonero 60 blanco. Cubo aqua blanco. Mirror serie 2 60x120.

MEDIDAS MUEBLE (MM) / UNIT DIMENSIONS / MESURES MEUBLE / MAßE SCHRANK / MISURE MOBILE / WYMIARY MEBLA / AFMETINGEN VAN DE MEUBELS / РАЗМЕРЫ МЕБЕЛИ

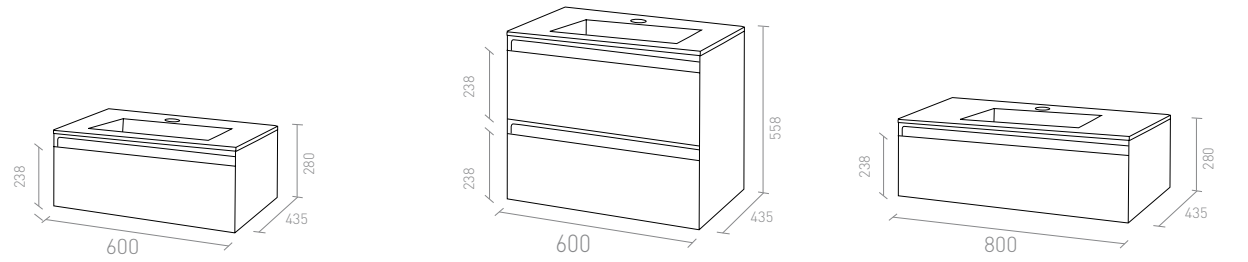

	Aqua 60	Aqua 60 2 cajones	Aqua 80
BLANCO	<b>68Q60BL</b>	<b>68Q6BL2</b>	<b>68Q80BL</b>
ANTRACITA	<b>68Q60AN</b>	<b>68Q6AN2</b>	<b>68Q80AN</b>
ENCINA	<b>68Q60NC</b>	<b>68Q6NC2</b>	<b>68Q80NC</b>
ARCE	<b>68Q60AR</b>	<b>68Q6AR2</b>	<b>68Q80AR</b>

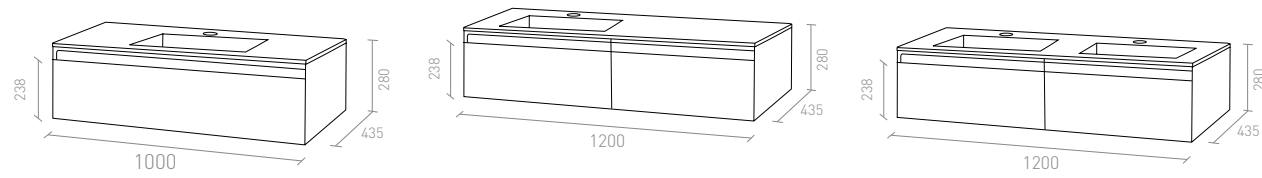

	Aqua 100	Aqua 120 seno izq.	Aqua 120 doble seno
BLANCO	<b>68Q10BL</b>	<b>68Q13BL</b>	<b>68Q12BL</b>
ANTRACITA	<b>68Q10AN</b>	<b>68Q13AN</b>	<b>68Q12AN</b>
ENCINA	<b>68Q10NC</b>	<b>68Q13NC</b>	<b>68Q12NC</b>
ARCE	<b>68Q10AR</b>	<b>68Q13AR</b>	<b>68Q12AR</b>

ENCIMERAS / COUNTERS / PLANS DE TOILETTE / WASCHTISCHE / TOP / BLATY ŁAZIENKOWE / WERKBLADEN / СТОЛЕШНИЦЫ

Porcelana / Porcelain (mm)

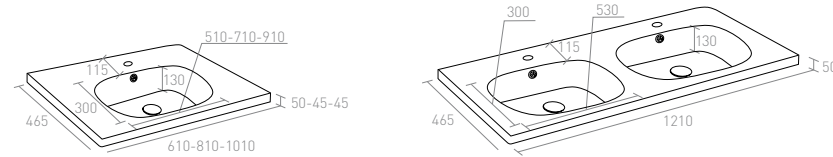

Los lavabos de porcelana de la serie Aqua pueden colocarse suspendidos y exentos de mueble cajonero.

The ceramic wash basins in the Aqua series can be wall mounted without the need for a vanity unit.

Les lavabos en céramique de la série Aqua peuvent être posés suspendus et sans meuble à tiroir.

Die Keramikwaschtische der Serie Aqua können an der Wand hängend und ohne Unterschrank mit Schubladen montiert werden.

I lavabi in ceramica della serie Aqua possono essere installati sospesi e senza cassettiera.

De keramische wastafels uit de Aqua serie kunnen aan de wand opgehanden worden los van het lade meubel.

Ceramiczne umywalki z serii Aqua mogą być podwieszane i instalowane same, bez szafki z szufladami.

Керамические умывальные раковины серии Aqua могут устанавливаться как подвесные, а также без предмета мебели с ящиками.

Encimera Porcelana 60	<b>68E60P4</b>
Encimera Porcelana 80	<b>68E80P4</b>
Encimera Porcelana 100	<b>68E10P4</b>
Encimera Porcelana 120	<b>68E12P4</b>

MineralMarmo(mm)

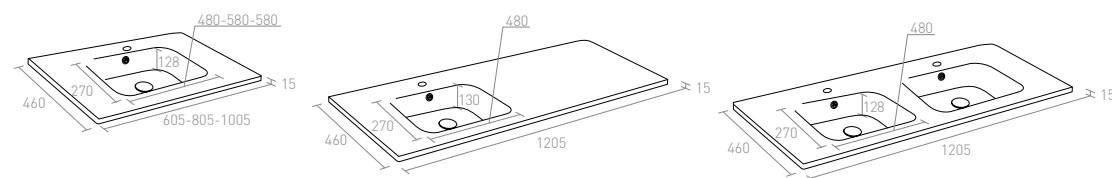

Encimera MinerlMarmo 60	<b>68E60M1</b>
Encimera MinerlMarmo 80	<b>68E80M1</b>
Encimera MinerlMarmo 100	<b>68E10M1</b>
Encimera MinerlMarmo seno izq. 120	<b>68E12M1</b>
Encimera MinerlMarmo doble seno 120	<b>68E12M2</b>

MUEBLES AUXILIARES / BATHROOM CABINETS / MEUBLES D'APPOINT / EINZELMÖBEL / MOBILI AUSILIARI / MEBLE POMOCNICZE / AANVULLENDE MEUBELS / ВОСПОМОГАТЕЛЬНЫЕ ПРЕДМЕТЫ МЕБЕЛИ

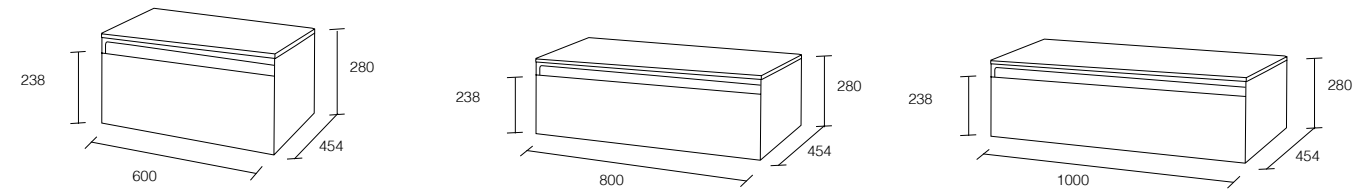

Cajonero Aqua Blanco	<b>68Q6BLT</b>	Cajonero Aqua Blanco	<b>68Q8BLT</b>	Cajonero Aqua Blanco	<b>68Q1BLT</b>
Cajonero Aqua Antrac.	<b>68Q6ANT</b>	Cajonero Aqua Antrac.	<b>68Q8ANT</b>	Cajonero Aqua Antrac.	<b>68Q1ANT</b>
Cajonero Aqua Encina	<b>68Q6NCT</b>	Cajonero Aqua Encina	<b>68Q8NCT</b>	Cajonero Aqua Encina	<b>68Q1NCT</b>
Cajonero Aqua Arce	<b>68Q6ART</b>	Cajonero Aqua Arce	<b>68Q8ART</b>	Cajonero Aqua Arce	<b>68Q1ART</b>

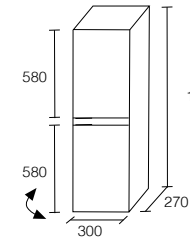

Tirador en el lado izquierdo. Apertura hacia la derecha. Handle on the left side. Opens to the right. Tirette sur le côté gauche. Ouverture vers la droite. Griff auf der linker Seite. Öffnung auf der rechten Seite. Maniglia sul lato sinistro. Apertura verso destra. Uchwyt z lewej strony. Otwierane na prawo. Handgreep aan de linkerkant. Opent naar rechts. Ручка с левой стороны. Открывание направо.

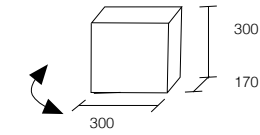

Tirador en el lado izquierdo. Apertura hacia la derecha. Handle on the left side. Opens to the right. Tirette sur le côté gauche. Ouverture vers la droite. Griff auf der linker Seite. Öffnung auf der rechten Seite. Maniglia sul lato sinistro. Apertura verso destra. Uchwyt z lewej strony. Otwierane na prawo. Handgreep aan de linkerkant. Opent naar rechts. Ручка с левой стороны. Открывание направо.

Columna Aqua Blanco	<b>68CAQBL</b>	Cubo Aqua Blanco	<b>68BAQBL</b>
Columna Aqua Antracita	<b>68CAQAN</b>	Cubo Aqua Antracita	<b>68BAQAN</b>
Columna Aqua Encina	<b>68CAQNC</b>	Cubo Aqua Encina	<b>68BAQNC</b>
Columna Aqua Arce	<b>68CAQAR</b>	Cubo Aqua Arce	<b>68BAQAR</b>

COLORES Y ACABADOS / COLOURS AND FINISHES / COULEURS ET FINITION / FARBEN UND FINISHES / COLORI E FINITURE / KOLORY I WYKOŃCZENIA / KLEUREN EN AFWERKINGEN / ЦВЕТА И ОТДЕЛКИ

Lacado Brillo / Gloss Lacquer / Laqué Brillant / Glänzend lackiert / Laccato lucido / Lakierowane z potyskiem / Glans gelakt / Лакированный блестящий

Madera / Wood / Bois / Holz / Legno / Drewno / Hout / Дерево



Blanco



Antracita



Arce



Encina

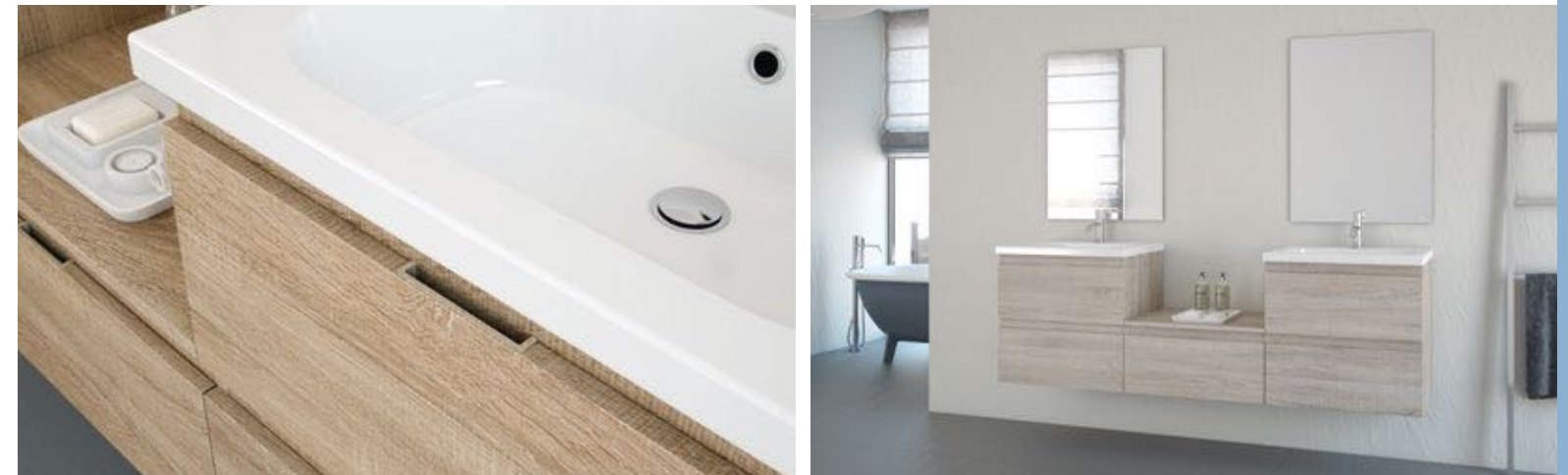

▣ Mueble: Aqua 60 2 cajones Arce (2 unidades). Encimera porcelana 60 (2 unidades). Mueble cajonero 60 Arce. Mirror serie 5 80x60.



# ASTER 60 / 80 / 100 / 120

## MEDIDAS MUEBLE (MM) / UNIT DIMENSIONS / MESURES MEUBLE / MAßE SCHRANK / MISURE MOBILE / WYMIARY MEBLA / AFMETINGEN VAN DE MEUBELS / РАЗМЕРЫ МЕБЕЛИ

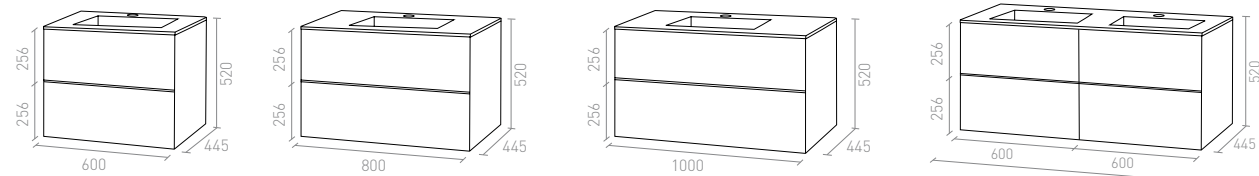

Aster 60

Aster 80

Aster 100

Aster 120

FRESNO	<b>68S60FE</b>	<b>68S80FE</b>	<b>68S10FE</b>
CEDRO	<b>68S60CE</b>	<b>68S80CE</b>	<b>68S10CE</b>
EBANO	<b>68S60EB</b>	<b>68S80EB</b>	<b>68S10EB</b>
BLANCO	<b>68S60BL</b>	<b>68S80BL</b>	<b>68S10BL</b>
CHOCOLATE	<b>68S60CH</b>	<b>68S80CH</b>	<b>68S10CH</b>
GRIS	<b>68S60GR</b>	<b>68S80GR</b>	<b>68S10GR</b>

Composición dos módulos de 60cm.  
Composition of two 60cm modules.  
Composition deux modules de 60cm.  
Schränkkomposition aus zwei 60-cm-Elementen.  
Composizione per due mobili da 60 cm.  
Zestaw dwóch modułów o szerokości 60 cm każdy.  
Samenstelling twee modules van 60cm.  
Состоящий из двух модулей по 60 см каждый.

## ENCIMERAS / COUNTERS / PLANS DE TOILETTE / WASCHTISCHE / TOP / BLATY ŁAZIENKOWE / WERKBLADEN / СТОЛЕШНИЦЫ

Porcelana / Porcelain (mm)

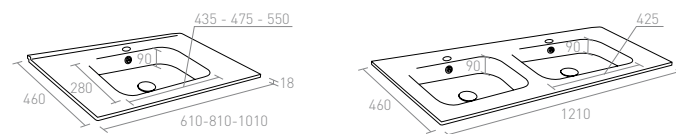

Encimera de doble seno para dos muebles de 60cm.  
Counter for double basin for two 60cm units.  
Plan de toilette à double creux pour vasque pour deux meubles de 60cm.  
Doppelbecken für zwei 60-cm-Schränke.  
Doppio lavabo per due mobili da 60 cm.  
Blat z dwiema umywalkami o szerokości 60 cm każda.  
Werkblad met dubbele wasbak voor twee modules van 60cm.  
Двойной умывальник со столешницей для двойного комплекта шкафов по 60 см каждый.

Encimera Porcelana 60	<b>68E60P3</b>
Encimera Porcelana 80	<b>68E80P3</b>
Encimera Porcelana 100	<b>68E10P3</b>
Encimera Porcelana 120	<b>68E12P3</b>

## MUEBLES AUXILIARES / BATHROOM CABINETS / MEUBLES D'APPOINT / EINZELMÖBEL / MOBILI AUSILIARI / MEBLE POMOCNICZE / AANVULLENDE MEUBELS / ВСПОМОГАТЕЛЬНЫЕ ПРЕДМЕТЫ МЕБЕЛИ

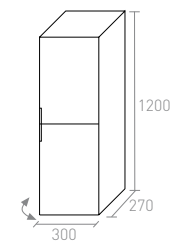

Tirador en el lado izquierdo.  
Apertura hacia la derecha.  
Handle on the left side.  
Opens to the right.  
Tirette sur le côté gauche.  
Ouverture vers la droite.  
Griff auf der linker Seite.  
Öffnung auf der rechten Seite.  
Maniglia sul lato sinistro.  
Apertura verso destra.  
Uchwyt z lewej strony.  
Otwierane na prawo.  
Handgreep aan de linkerkant.  
Opent naar rechts.  
Ручка с левой стороны.  
Открытие направо.

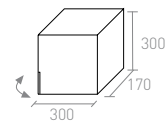

Tirador en el lado izquierdo.  
Apertura hacia la derecha.  
Handle on the left side.  
Opens to the right.  
Tirette sur le côté gauche.  
Ouverture vers la droite.  
Griff auf der linker Seite.  
Öffnung auf der rechten Seite.  
Maniglia sul lato sinistro.  
Apertura verso destra.  
Uchwyt z lewej strony.  
Otwierane na prawo.  
Handgreep aan de linkerkant.  
Opent naar rechts.  
Ручка с левой стороны.  
Открытие направо.

Columna Aster Fresno	<b>68CASFE</b>	Cubo Aster Fresno	<b>68BASFE</b>
Columna Aster Cedro	<b>68CASCE</b>	Cubo Aster Cedro	<b>68BASCE</b>
Columna Aster Ebano	<b>68CASEB</b>	Columna Aster Ebano	<b>68BASEB</b>
Columna Aster Blanco	<b>68CASBL</b>	Cubo Aster Blanco	<b>68BASBL</b>
Columna Aster Chocolate	<b>68CASCH</b>	Cubo Aster Chocolate	<b>68BASCH</b>
Columna Aster Gris	<b>68CASGR</b>	Cubo Aster Gris	<b>68BASGR</b>

## COLORES Y ACABADOS / COLOURS AND FINISHES / COULEURS ET FINITION / FARBEN UND FINISHS / COLORI E FINITURE / KOLORY I WYKOŃCZENIA / KLEUREN EN AFWERKINGEN / ЦВЕТА И ОТДЕЛКИ

Lacado Brillo / Gloss Lacquer / Laqué Brillant / Glänzed lackiert / Laccato lucido / Lakierowane z potyskiem / Glans gelakt / Лакированный блестящий

Madera / Wood / Bois / Holz / Legno / Drewno / Hout / Дерево



▣ Mueble: Aster Ebano 100. Encimera Porcelana 100. Mirror Serie 5 60 x 80. Cubo Aster Ebano.

# MOON 49 / 55 / 60 / 80 / 100

## MEDIDAS MUEBLE (MM) / UNIT DIMENSIONS / MESURES MEUBLE / MAßE SCHRANK / MISURE MOBILE / WYMIARY MEBLA / AFMETINGEN VAN DE MEUBELS / РАЗМЕРЫ МЕБЕЛИ

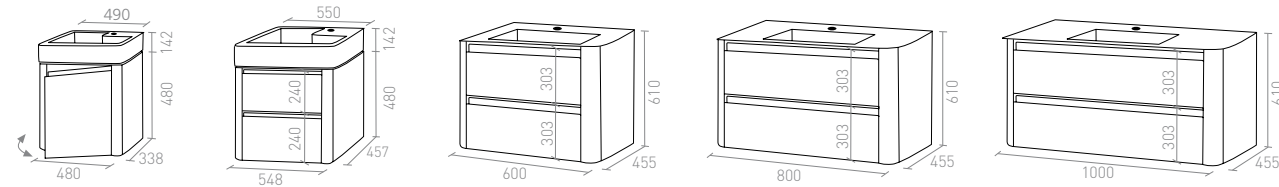

Moon Compacto 49    Moon Compacto 55    Moon 60    Moon 80    Moon 100

MADERA NOGAL	<b>68C49NO</b>	<b>68C55NO</b>	<b>68M60NO</b>	<b>68M80NO</b>	<b>68M10NO</b>
MADERA CAFÉ	<b>68C49CF</b>	<b>68C55CF</b>	<b>68M60CF</b>	<b>68M80CF</b>	<b>68M10CF</b>
PISTACHO	<b>68C49PI</b>	<b>68C55PI</b>	<b>68M60PI</b>	<b>68M80PI</b>	<b>68M10PI</b>
MORA	<b>68C49MR</b>	<b>68C55MR</b>	<b>68M60MR</b>	<b>68M80MR</b>	<b>68M10MR</b>
ARABICA	<b>68C49AR</b>	<b>68C55AR</b>	<b>68M60AR</b>	<b>68M80AR</b>	<b>68M10AR</b>

## ENCIMERAS / COUNTERS / PLANS DE TOILETTE / WASCHTISCHE / TOP / BLATY ŁAZIENKOWE / WERKBLADEN / СТОЛЕШНИЦЫ

Porcelana / Porcelain (mm.)

Solid Surface (mm.)

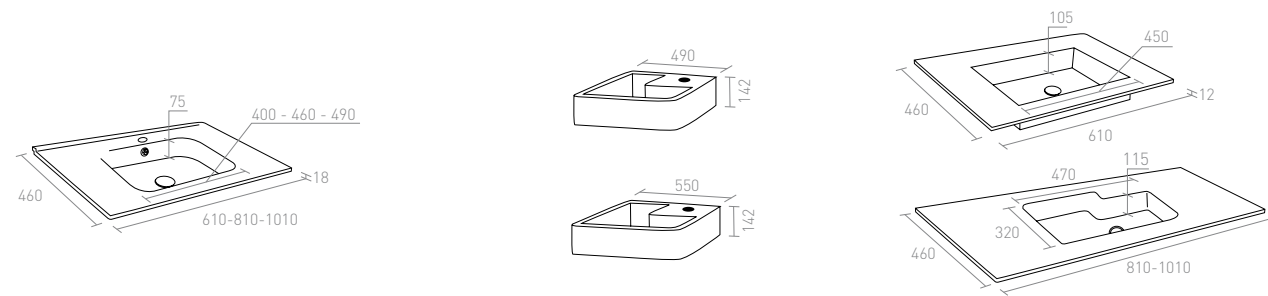

Porcelana 60	<b>68E60P2</b>
Porcelana 80	<b>68E80P2</b>
Porcelana 100	<b>68E10P2</b>

Solid Surface 49	<b>68E49R1</b>	Solid Surface 60	<b>68E60R2</b>
Solid Surface 55	<b>68E55R1</b>	Solid Surface 80	<b>68E80R2</b>
		Solid Surface 100	<b>68E10R2</b>

## COLORES Y ACABADOS / COLOURS AND FINISHES / COULEURS ET FINITION / FARBEN UND FINISHS / COLORI E FINITURE / KOLORY I WYKOŃCZENIA / KLEUREN EN AFWERKINGEN / ЦВЕТА И ОТДЕЛКИ

Madera / Wood / Bois / Holz / Legno / Drewno / Hout / Дерево

Lacado Brillo / Gloss Lacquer / Laqué Brillant / Glänzed lackiert / Laccato lucido / Lakierowane z potyskiem / Glans gelakt / Лакированный блестящий



Madera Nogal



Madera Café



Pistacho



Mora



Arabica



▣ Mueble: Moon Compacto 55 Mora. Encimera Solid Surface Compacto 55. Mirror Serie 4 Blanco D50.



# PLANET 60 / 80 / 100 / 120

## MEDIDAS MUEBLE (MM) / UNIT DIMENSIONS / MESURES MEUBLE / MAßE SCHRANK / MISURE MOBILE / WYMIARY MEBLA / AFMETINGEN VAN DE MEUBELS / РАЗМЕРЫ МЕБЕЛИ

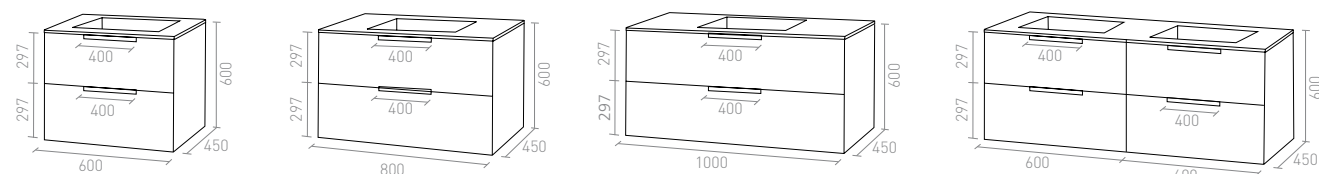

Planet 60

Planet 80

Planet 100

Planet 120

BLANCO	<b>68P60BL</b>	<b>68P80BL</b>	<b>68P100BL</b>
NEGRO	<b>68P60NG</b>	<b>68P80NG</b>	<b>68P100NG</b>
CHOCOLATE	<b>68P60CH</b>	<b>68P80CH</b>	<b>68P100CH</b>
BURDEOS	<b>68P60BU</b>	<b>68P80BU</b>	<b>68P100BU</b>

Compuesto por dos módulos de 60cm.  
Composition of two 60cm modules.  
Composition deux modules de 60cm.  
Schränkkomposition aus zwei 60-cm-Elementen.  
Composizione per due mobili da 60 cm.  
Zestaw dwóch modułów o szerokości 60 cm każdy.  
Samenstelling twee modules van 60cm.  
Состоящий из двух модулей по 60 см каждый.

## ENCIMERAS / COUNTERS / PLANS DE TOILETTE / WASCHTISCHE / TOP / BLATY ŁAZIENKOWE / WERKBLADEN / СТОЛЕШНИЦЫ

### Porcelana / Porcelain (mm.)

### Solid Surface (mm.)

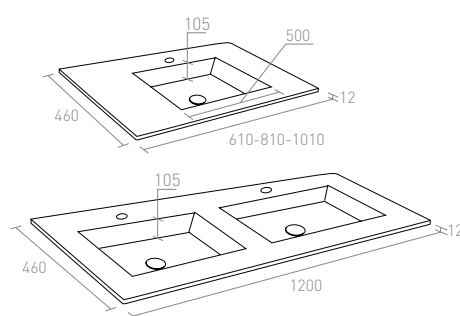
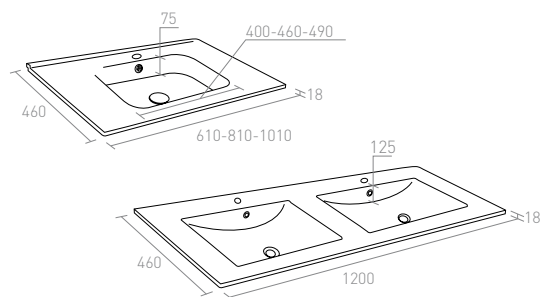

Encimera de doble seno para dos muebles de 60cm.  
Counter for double basin for two 60cm units.  
Plan de toilette à double creux pour vasque pour deux meubles de 60cm.  
Doppelbecken für zwei 60-cm-Schränke.  
Doppio lavabo per due mobili da 60 cm.  
Blat z dwiema umywalkami o szerokości 60 cm każda.  
Werkblad met dubbele wasbak voor twee modules van 60cm.  
Двойной умывальник со столешницей для двойного комплекта шкафов по 60 см каждый.

Porcelana 60	<b>68E60P1</b>
Porcelana 80	<b>68E80P1</b>
Porcelana 100	<b>68E10P1</b>
Porcelana 120	<b>68E12P1</b>

Solid Surface 60	<b>68E60R1</b>
Solid Surface 80	<b>68E80R1</b>
Solid Surface 100	<b>68E10R1</b>
Solid Surface 120	<b>68E12R1</b>

## MUEBLES AUXILIARES / BATHROOM CABINETS / MEUBLES D'APPOINT / EINZELMÖBEL / MOBILI AUSILIARI / MEBLE POMOCNICZE / AANVULLENDE MEUBELS / ВСПОМОГАТЕЛЬНЫЕ ПРЕДМЕТЫ МЕБЕЛИ

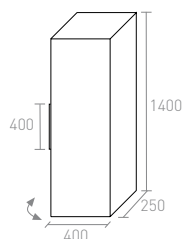

Tirador en el lado izquierdo.  
Apertura hacia la derecha.  
Handle on the left side.  
Opens to the right.  
Tirette sur le côté gauche.  
Ouverture vers la droite.  
Griff auf der linken Seite.  
Öffnung auf der rechten Seite.  
Maniglia sul lato sinistro.  
Apertura verso destra.  
Uchwyt z lewej strony.  
Otwierane na prawo.  
Handgreep aan de linkerkant.  
Opent naar rechts.  
Ручка с левой стороны.  
Открытие направо.

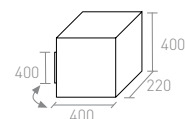

Tirador en el lado izquierdo.  
Apertura hacia la derecha.  
Handle on the left side.  
Opens to the right.  
Tirette sur le côté gauche.  
Ouverture vers la droite.  
Griff auf der linken Seite.  
Öffnung auf der rechten Seite.  
Maniglia sul lato sinistro.  
Apertura verso destra.  
Uchwyt z lewej strony.  
Otwierane na prawo.  
Handgreep aan de linkerkant.  
Opent naar rechts.  
Ручка с левой стороны.  
Открытие направо.

Columna Planet Blanco	<b>68CPLBL</b>
Columna Planet Negro	<b>68CPLNG</b>
Columna Planet Chocolate	<b>68CPLCH</b>
Columna Planet Burdeos	<b>68CPLBU</b>

Cubo Planet Blanco	<b>68BPLBL</b>
Cubo Planet Negro	<b>68BPLNG</b>
Cubo Planet Chocolate	<b>68BPLCH</b>
Cubo Planet Burdeos	<b>68BPLBU</b>

## COLORES Y ACABADOS / COLOURS AND FINISHES / COULEURS ET FINITION / FARBEN UND FINISHS / COLORI E FINITURE / KOLORY I WYKOŃCZENIA / KLEUREN EN AFWERKINGEN / ЦВЕТА И ОТДЕЛКИ

Laminado Brillo / Gloss Laminate / Laminé Brillant / Glänzted laminiert / Laminato lucido / Laminowane z połyskiem / Glans Laminaat / Ламинированный блестящий



Blanco Negro Chocolate Burdeos



▣ Mueble: Planet 60 Chocolate (2 unidades). Encimera Solid Surface 120. Mirror Serie 1 60 x 120.



SERIE 1

800x500 / 600x800 / 600x1000 / 600x1200 mm

Mirror Serie 1 60x80	<b>68M1S80</b>
Mirror Serie 1 60x100	<b>68M1S10</b>
Mirror Serie 1 60x120	<b>68M1S12</b>
Mirror Serie 1 80x50	<b>68M1S50</b>

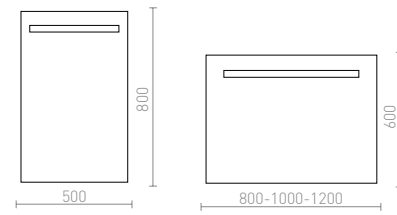

Espejo rectangular biselado. Iluminación lineal, franja superior iluminada con leds.  
 Rectangular bevelled mirror. Strip lighting, upper edge lit by LEDs.  
 Miroir rectangulaire biseauté. Eclairage linéaire, frange supérieure éclairé par des DEL.  
 Rechteckiger Spiegel, geschliffen. Lineare Beleuchtung, oberer Teil mit LED-Beleuchtung.  
 Specchio rettangolare bisellato. Illuminazione lineare, fascia superiore illuminata a led.  
 Prostokątne lustro o ściętych krawędziach. Oświetlenie linowe LED w górnej części.  
 Rechthoekige, afgeschuinde spiegel. Lineaire verlichting, bovenste rand verlicht met leds  
 Прямоугольное зеркало со скошенным краем, линейное освещение, верхняя полоса со светодиодной подсветкой.

SERIE 2

600x600 / 600x800 / 600x1000 / 600x1200 mm

Mirror Serie 2 60x60	<b>68M2S60</b>
Mirror Serie 2 60x80	<b>68M2S80</b>
Mirror Serie 2 60x100	<b>68M2S10</b>
Mirror Serie 2 60x120	<b>68M2S12</b>

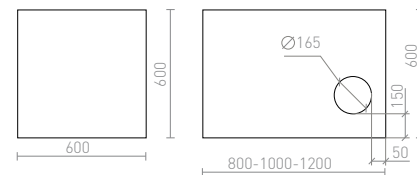

Espejo rectangular biselado con lupa de aumento 3x1. Retroiluminado con leds.  
 Rectangular bevelled mirror with 3x magnifier. Backlit with LEDs.  
 Miroir rectangulaire biseauté avec loupe de grossissement 3x. Rétro-éclairage par des DEL.  
 Rechteckiger Spiegel geschliffen, mit Vergrößerungsspiegel (3-fach). LED-Hinterbeleuchtung.  
 Specchio rettangolare bisellato con ingrandimento 3x1. Retroilluminato a led.  
 Prostokątne lustro o ściętych krawędziach z lusterkiem powiększającym 3x1. Podświetlenie tylne LED.  
 Rechthoekig, afgeschuinde spiegel met vergrootglas 3x1. Van achter verlicht met leds.  
 Прямоугольное зеркало со скошенной кромкой, с увеличительным стеклом 3 x 1. Задняя светодиодная подсветка.

SERIE 3

800x500 / 600x800 / 600x1000 / 600x1200 mm

Mirror Serie 3 60x80	<b>68M3S80</b>
Mirror Serie 3 60x100	<b>68M3S10</b>
Mirror Serie 3 60x120	<b>68M3S12</b>
Mirror Serie 3 80x50	<b>68M3S50</b>

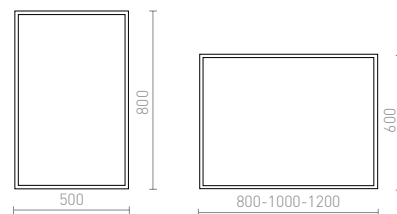

Espejo marco aluminio. Specchio cornice alluminio  
 Mirror in aluminum frame. Lustro w aluminiowej oprawie.  
 Miroir cadre aluminium. Spiegel met een aluminium lijst.  
 Spiegel mit Aluminiumrahmen. Зеркало в алюминиевой раме

SERIE 4

Ø 500 mm / Ø 700 mm

Blanco Burdeos Negro

Mirror Serie 4 Burdeos D50	<b>68M4S5R</b>
Mirror Serie 4 Blanco D50	<b>68M4S5B</b>
Mirror Serie 4 Negro D50	<b>68M4S5N</b>
Mirror Serie 4 Burdeos D70	<b>68M4S7R</b>
Mirror Serie 4 Blanco D70	<b>68M4S7B</b>
Mirror Serie 4 Negro D70	<b>68M4S7N</b>

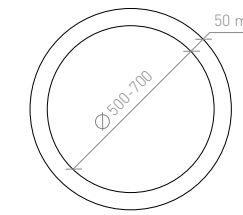

Espejo redondo sobre cristal brillo.  
 Round mirror on bright glass.  
 Miroir rond sur verre brillant.  
 Runder Spiegel auf Glanzkristall.  
 Specchio rotondo su vetro lucido.  
 Okrągłe lustro na wypolerowanym szkło.  
 Ronde spiegel op glanzend glas.  
 Круглое зеркало на стекле с блеском.

SERIE 5

800x600 / 600x800 / 600x1000 / 600x1200 mm

Mirror Serie 5 80x60	<b>68M5S60</b>
Mirror Serie 5 60x80	<b>68M5S80</b>
Mirror Serie 5 60x100	<b>68M5S10</b>
Mirror Serie 5 60x120	<b>68M5S12</b>

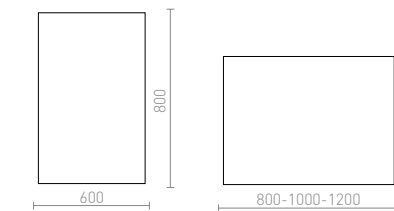

Espejo microbiselado.  
 Microbeveled mirror.  
 Miroir micro - biseauté  
 Spiegel mit Mikro-Fase.  
 Specchio microbisellato.  
 Lustro o lekko ściętych krawędziach.  
 Micro-afgeschuinde spiegel.  
 Зеркало со скошенной микроромкой.



ENCIMERAS SOLID SURFACE SOLID SURFACE COUNTERS / PALN DE TOILETTE SOLID SURFACE / WASCHTISCHE SOLID SURFACE  
TOP SOLID SURFACE / BLATY ŁAZIENKOWE SOLID SURFACE / WERKBLADEN SOLID SURFACE / СТОЛЕШНИЦЫ SOLID SURFACE

Características Técnicas

Superficie sólida de resina e hidróxido de alúmina.

Esta superficie es no porosa, lo que facilita su limpieza e impide la presencia de las bacterias.

La superficie sólida SolidSurface permite su renovación periódica ante la aparición de rayas o manchas difíciles de eliminar, de modo que el producto puede mantener su aspecto original con un mantenimiento sencillo.

Technical features

Solid surface of resin and aluminum hydroxide.

This surface is not porous, which makes cleaning easier and prevents the appearance of bacteria.

Due to its solid surface, SolidSurface allows for the periodic renovation of the basin if hard-to-remove stains or scratches appear, so the product can keep its original appearance with simple maintenance.

Spécifications techniques

Surface solide de résine et hydroxyde d'aluminium.

Cette surface n'est pas poreuse, ce qui permet un facile nettoyage qui empêche l'apparition de bactéries.

La surface solide de SolidSurface permet le renouvellement régulier de rayures ou tâches qui peuvent devenir difficiles à nettoyer dans le cas d'un autre matériel, de sorte que le produit peut garder son aspect original avec un simple maintien.

Technische Daten

Feste Oberfläche aus Harz und Tonerdehydrat.

Diese Oberfläche ist nicht porös, daher leicht zu reinigen und bakterienabweisend.

Die feste Oberfläche SolidSurface kann, wenn Kratzer oder schwer zu entfernende Flecken entstehen, regelmäßig erneuert werden. Ein einfacher Pflegevorgang, durch den SolidSurface immer wieder wie neu aussehen kann.

Caratteristiche tecniche

Solid Surface di resina e idrossido di alluminio.

Questa superficie non è porosa, il che ne agevola la pulizia e impedisce la proliferazione dei batteri.

In caso di graffi o macchie difficili da rimuovere, è possibile ripristinare l'aspetto originale della Solid Surface con una semplice manutenzione.

Właściwości techniczne

Solidna powierzchnia z konglomeratu żywicy i wodorotlenku glinu.

Jest to powierzchnia nieporowata, łatwa do utrzymania w czystości i odporna na rozwój bakterii.

Trwałą powierzchnia SolidSurface można okresowo odnowić w razie pojawienia się rys czy trudnych do wyeliminowania plam, przez co zachowuje swój pierwotny wygląd dzięki prostym zabiegom pielęgnacyjnym.

Technische kenmerken

Solide oppervlak van hars en aluminiumhydroxide.

Het oppervlak is niet poreus, dit maakt het eenvoudiger te reinigen en voorkomt de aanwezigheid van bacteriën.

Dankzij het solide oppervlak SolidSurface is het mogelijk dat periodiek te vervangen wanneer er krassen of moeilijk te verwijderen vlekken op komen, dat maakt dat het product zijn oorspronkelijke uiterlijk behoudt en zeer weinig onderhoud nodig heeft.

Технические характеристики

Твердая поверхность из смолы и гидроксида алюминия.

Эта поверхность не пористая, благодаря чему она легче очищается и препятствует наличию бактерий.

Твердая поверхность SolidSurface допускает периодическое обновление при появлении трудновыводимых царапин или пятен, поэтому для сохранения первоначального внешнего вида изделия не требуется сложного ухода.



ESPECIFICACIONES COMUNES COMMON SPECIFICATIONS / SPÉCIFICATIONS COMMUNES / GEMEINSAME SPEZIFIKATIONEN / SPECIFICHE COMUNI / СЕЧНУ ОБЉНЕ / ALGEMENE SPECIFICATIES / ОБЩИЕ СПЕЦИФИКАЦИИ

CARACTERÍSTICA / CHARACTERISTIC / CARACTÉRISTIQUES / EIGENSCHAFT / CARATTERISTICA / WŁAŚCIWOŚCI / KENMERK / ХАРАКТЕРИСТИКА	ESPECIFICACIÓN / SPECIFICATION / SPÉCIFICATIONS / SPEZIFIKATION / SPECIFICA / WŁAŚCIWOŚCI / SPECIFICATIE / СПЕЦИФИКАЦИЯ	ENSAYO / TEST METHOD / MÉTHODE D'ESSAI / PRÜFMETHODE / PROVA / PRŮBA / PROEF / ИСПЫТАНИЕ
Resistencia al calor radiante / Resistance to radiant heat Résistance à la chaleur radiante / Beständigkeit gegen strahlende Wärme Resistenza al calore radiante / Wytrzymałość cieplna / Weerstand tegen stralingswarmte / Устойчивость к нагреванию от солнечного света	600 s	NEMA LD 3-3.10
Expansión térmica / Thermal expansion / Expansion thermique Wärmeausdehnung / Espansione termica / Rozszerzalność cieplna / Thermische expansie / Тепловое расширение	≤ 5,4*105 mm/mm °C	ASTM E 228
Resistencia a la flexión / Flexural resistance / Résistance au fléchissement / Biegefestigkeit / Resistenza alla flessione / Odporność na nacisk / Buigsterkte / Прочность на изгиб	≥ 27,8 Мпа	ASTM D 790
Módulo de flexión / Flexural modulus / Module de fléchissement / Biegemodul / Modulo di flessione / Степень Гибкости	≥ 6895 Мпа	ASTM D 790
Dureza Barcol / Barcol hardness / Dureté Barcol / Barcol-Härte / Durezza Barcol / Twardość wg Barcola / Barcol hardheid / Твердость по Барколю	50-70	ASTM D 2583
Planitud / Flatness / Planéité / Ebenflächigkeit / Planarità Płaskość / Vlakheid / Плоскостность	≤ 1,6 mm	ISSFA SST 4.1-00
Resistencia al impacto / Impact resistance / Résistance à l'impact / Schlagfestigkeit / Resistenza all'impatto / Wytrzymałość na uderzenie / Slagvastheid / Устойчивость к ударам	Pasa a 1525 mm	ISSFA SST 6.1-00

ESPECIFICACIONES PARA MATERIALES ESTÁNDAR / SPECIFICATIONS FOR STANDARD MATERIALS / SPÉCIFICATIONS POUR MATÉRIAUX STANDARDS / SPEZIFIKATIONEN FÜR STANDARDMATERIAL / SPECIFICHE PER MATERIALI STANDARD / STANDARDOWE SPECYFIKACJE TWORZYWA / SPECIFICATIES VOOR STANDAARDMATERIALEN / СПЕЦИФИКАЦИИ ДЛЯ СТАНДАРТНЫХ МАТЕРИАЛОВ

CARACTERÍSTICA / CHARACTERISTIC / CARACTÉRISTIQUES / EIGENSCHAFT / CARATTERISTICA / WŁAŚCIWOŚCI / KENMERK / ХАРАКТЕРИСТИКА	ESPECIFICACIÓN / SPECIFICATION / SPÉCIFICATIONS / SPEZIFIKATION / SPECIFICA / WŁAŚCIWOŚCI / SPECIFICATIE / СПЕЦИФИКАЦИЯ	ENSAYO / TEST METHOD / MÉTHODE D'ESSAI / PRÜFMETHODE / PROVA / PRŮBA / PROEF / ИСПЫТАНИЕ
Comportamiento frente a los microorganismos / Fungal resistance / Comportement face aux micro-organismes / Verhalten gegenüber Mikroorganismen Comportamento nei confronti dei microrganismi / Odporność na mikroorganizmy Bestendigheid tegen micro-organismen / Поведение по отношению к микроорганизмам	sin crecimiento / no growth sans croissance / Kein Wachstum non proliferano / nie odnotowano wzrostu geen groei / не размножаются	ASTM G21
Resistencia a las bacterias / Bacterial resistance Résistance aux bactéries / Widerstand gegen Bakterien Resistenza ai batteri / Odporność na bakterie / Bestendigheid tegen bacteriën / Устойчивость к бактериям	sin crecimiento / no growth sans croissance / Kein Wachstum non proliferano / nie odnotowano wzrostu geen groei / не размножаются	ASTM G22
Consistencia del color / Colour consistency Consistance de la couleur / Farbkonsistenz / Consistenza del colore Jednorodność koloru / Kleurconsistentie / Консистенция цвета	pasa / passes / passe / bestanden prova superata / próba zdana / voldoend / пройдено	ISSFA SST 2.1-00
Resistencia al manchado / Stain resistance Résistance aux taches / Fleckfestigkeit / Resistenza alle macchie / Odporność na plamy / Vlekbestendigheid / Устойчивость к пятнам	<52	ISSFA SST 3.1-00
Defectos visuales / Visual defects Défauts visuels / Visuelle Mängel / Difetti visivi Widoczne defekty / Visuele defecten / Визуальные дефекты	pasa / passes / passe / bestanden prova superata / próba zdana / voldoend / пройдено	ISSFA SST 5.1-00
Resistencia a la luz / Light resistance Résistance à la lumière / Lichtfestigkeit / Resistenza alla luce Odporność na światło / Lichtbestendigheid / Устойчивость к свету	sin efecto / no effect sans effet / Keine Wirkung nessuna alterazione / bez zmian geen waarneembaar effect / без эффекта	ISSFA SST 7.1-00
Resistencia al agua hirviendo / Boiling water resistance Résistance à l'eau bouillante / Beständigkeit gegen kochendes Wasser Resistenza all'acqua bollente / Odporność na wrzątek Bestand tegen kokend water / Устойчивость к кипящей воде	sin efecto / no effect sans effet / Keine Wirkung nessuna alterazione / bez zmian geen waarneembaar effect / без эффекта	ISSFA SST 8.1-00
Resistencia a altas temperaturas / Resistance to high temperatures Résistance aux hautes températures / Beständigkeit gegen hohe Temperaturen Resistenza alte temperature / Odporność na wysokie temperatury Bestand tegen kokend water / Устойчивость к высоким температурам	sin efecto / no effect sans effet / Keine Wirkung nessuna alterazione / bez zmian geen waarneembaar effect / без эффекта	ISSFA SST 9.1-00

ENCIMERAS MINERALMARMO® / MINERALMARMO® COUNTERS / PLAN DE TOILETTE MINERALMARMO® / WASCHTISCHE MINERALMARMO / TOP MINERALMARMO® / BLATY ŁAZIENKOWE MINERALMARMO® / WERKBLADEN MINERALMARMO® / СТОЛЕШНИЦЫ MINERALMARMO®

Características Técnicas

Mineralmarmo® es un material compuesto por minerales naturales y resina poliéster. La limpieza habitual de MineralMarmo® garantiza la conservación de su perfección original e impide la aparición de desgaste con el pasar del tiempo. Se aconseja no usar ácidos y bases fuertes (como el ácido clorhídrico y soda cáustica) cetonas (acetona), disolventes clorados (trielina) y productos usados en el sector de la pintura.

Technical features

MineralMarmo® is a material made up of natural minerals with polyester resin. Regular cleaning ensures that the natural beauty of MineralMarmo® is preserved, and prevents signs wear and tear. Some aggressive chemicals may damage the surface of MineralMarmo®. The use of strong acids and bases (such as hydrochloric acid and caustic soda), ketenes (acetone), chlorinated solvents (trichloroethylene) and painting related products is not recommended.

Spécifications techniques

Le MineralMarmo® est un matériau composé de minéraux naturels et de résine polyester. Le nettoyage fréquent du MineralMarmo® garantit le maintien de son éclat d'origine, sans laisser apparaître aucun signe d'usure au fil du temps. Certaines substances chimiques agressives attaquent les surfaces en MineralMarmo®. Aussi est-il vivement déconseillé d'utiliser des acides et des bases fortes (comme par exemple l'acide chlorhydrique et la soude caustique), des cétones (acétone), des solvants chlorurés (trichloréthylène) ainsi que les produits utilisés dans le domaine du vernissage.

Technische Daten

Mineralmarmo® ist ein Material bestehend aus natürlichen Mineralen und Polyesterharz. Mit einer normalen Reinigung von MineralMarmo® wird gewährleistet, dass die ursprüngliche Perfektion erhalten bleibt und verhindert Abnutzungserscheinungen im Lauf der Zeit. Von der Benutzung von starken Säuren oder Laugen (wie Salzsäure oder Natronlauge), Ketonen (Azeton), gechlorten Lösungsmitteln (Trichlorethen) und Produkten, die im Zusammenhang mit Malerfarben benutzt werden, ist abzuraten.

Caratteristiche tecniche

Mineralmarmo® è un materiale composto da minerali naturali e da resina poliester. La pulizia regolare di Mineralmarmo® ne garantisce la conservazione in perfetto stato e impedisce la comparsa di tracce d'usura con l'andar del tempo. Si consiglia di non usare acidi e basi forti (quali acido cloridrico e soda caustica), chetoni (acetone), solventi clorati (trielina) e prodotti usati nel settore della verniciatura.

Właściwości techniczne

Mineralmarmo® is een materiaal dat bestaat uit natuurlijke mineralen en polyesterhars. Als MineralMarmo® regelmatig gereinigd wordt behoudt het zijn oorspronkelijke perfectie en wordt slijtage in de loop van de tijd voorkomen. Er wordt aangeraden geen zuren en sterke basen (zoals zoutzuur en natronloog) ketonen (aceton), chloorhoudende oplosmiddelen (trichloorethen) en producten die gebruikt worden in de verfsector te gebruiken.

Technische kenmerken

Mineralmarmo® to materiał składający się z naturalnych minerałów i żywicy poliestrowej. Codzienna pielęgnacja MineralMarmo® gwarantuje zachowanie właściwości materiału i zapobiega pojawianiu się oznak zużycia z biegiem czasu. Zaleca się nie stosować kwasów i mocnych zasad (takich jak kwas solny czy soda kaustyczna), ketonów (aceton), rozpuszczalników chlorowanych (trichloroeten), czy produktów stosowanych do farb.

Технические характеристики

Mineralmarmo — это материал, состоящий из натуральных минералов и полиэфирной смолы. Обычная чистка MineralMarmo® гарантирует его сохранение в первоначальном идеальном виде и препятствует изнашиванию с течением времени. Рекомендуется не использовать сильные кислотные и щелочные средства (например, хлористоводородную кислоту или каустическую соду), кетоны (ацетон), хлорированные растворители (трихлорэтилен) и средства, применяемые в сфере окраски.

ESPECIFICACIONES COMUNES COMMON SPECIFICATIONS / SPÉCIFICATIONS COMMUNES / GEMEINSAME SPEZIFIKATIONEN / SPECIFICHE COMUNI / СЕЧУ ОГОЛНЕ / ALGEMENE SPECIFICATIES / ОБЩИЕ СПЕЦИФИКАЦИИ

CARACTERÍSTICA / CHARACTERISTIC / CARACTÉRISTIQUES / EIGENSCHAFT / CARATTERISTICA / WŁAŚCIWOŚCI / KENMERK / ХАРАКТЕРИСТИКА	ESPECIFICACIÓN / SPECIFICATION / SPÉCIFICATIONS / SPEZIFIKATION / SPECIFICA / WŁAŚCIWOŚCI / SPECIFICATIE / СПЕЦИФИКАЦИЯ	ENSAYO / TEST METHOD / MÉTHODE D'ESSAI / PRÜFMETHODE / PROVA / PRÓBA / PROEF / ИСПЫТАНИЕ
Conformidad marcado CE / CE mark conformity / Conformité marquage CE / Konformität CE-Kennzeichnung / Conformità marchio CE / Voldoet aan CE marking / Zgodność z normami CE / Соответствие маркировке CE	obtenida / achieved	UNEN 14688:2007
Densidad / Density / Densité / Dichte / Densità / Dichtheid / Gęstość / Плотность	1.7-2.0 g/cm <sup>3</sup>	Metodo Interno / Internal method
Absorción del agua despues de 48 horas / Water absorption after 48 hours / Absorption d'eau après 48 heures / Wasserabsorption nach 48 Stunden / Assorbimento d'acqua dopo 48 ore / Wateropname na 48 uur / Wchłanianie wody po upływie 48 godzin / Поглощение воды через 48 часов	<0,2 %	UNI EN 62:2001
Dureza Barcol / Barcol hardness / Dureté Barcol / Barcol-Härte / Durezza Barcol / Twardość wg Barcola / Barcol hardheid / Твердость по Барколю	50 Barcol Scale	ASTM D 2583-81
Contacto con alimentos-migración global/ Contact with foodstuff-overall migration / Contact avec aliments-migration totale / Kontakt mit Lebensmitteln-allgemeine Migration / Contatto con alimenti-migrazione complessiva / Contact met levensmiddelen-Totale migratie / Kontakt z jedzeniem – migracja globalna / Контакт с пищевыми продуктами – глобальная миграция	Agua destilada / Distilled water: 0.7 mg/ dm <sup>2</sup> Ácido acético / Acetic acid3%: 3.8 mg/ dm <sup>2</sup> Etanol / Ethanol 10%: 1.2 mg/ dm <sup>2</sup>	UNI EN 1186:2003
Coefficiente de expansión térmica lineal desde 10° a +20 °C / Coefficient of longitudinal thermal expansion from 10° to +20 °C / Coefficient d'expansion thermique linéaire de 10° à +20 °C / Koeffizient der linearen Wärmeausdehnung von 10° bis +20 °C / Coefficiente d'espansione termica lineare da 10° a +20 °C / Logitudinale termale uitzettingscoëfficiënt van -10 tot + 20°C / Współczynnik rozszerzalności cieplnej liniowej od 10° do +20 °C / Коэффициент линейного теплового расширения от 10° до +20 °C	34,3=µm/m °C	ASTM E 831:2006
Coefficiente de expansión térmica lineal desde 75° a +125 °C / Coefficient of longitudinal thermal expansion from 75° to +125 °C / Coefficient d'expansion thermique linéaire de 75° à +125 °C / Koeffizient der linearen Wärmeausdehnung von 75° bis +125 °C / Coefficiente d'espansione termica lineare da 75° a +125 °C / Logitudinale termale uitzettingscoëfficiënt van 75 tot + 125°C / Współczynnik rozszerzalności cieplnej liniowej od 75° do +125 °C / Коэффициент линейного теплового расширения от 75° до +125 °C	85,7=µ m/m °C	ASTM E 831:2006
Resistencia a la flexión / Flexing resistance / Résistance à la flexion / Biegefestigkeit / Resistenza a flessione / Buigweerstand / Odporność na zginanie / Прочность на изгиб	32.3 MPa	EN ISO 178:2003
Resistencia a la flexión-Módulo de elasticidad / Flexing resistance-Coefficient of elasticity / Résistance à la flexion-Module d'élasticité / Biegefestigkeit-Elastizitätsmodul / Resistenza a flessione-Modulo elastico / Buigweerstand-Elasticiteitscoëfficiënt / Odporność na zginanie-Modul elastyczności / Прочность на изгиб-Модуль упругости	9102 MPa	EN ISO 178:2003
Resistencia a la tracción / Tensile strength / Résistance à la traction / Zugfestigkeit / Resistenza a trazione / Treksterkte / Odporność na ścieranie / Прочность на растяжение	19.8 MPa	EN ISO 527:1996
Resistencia a la tracción-Extensión de rotura / Tensile strength-Elongation at rupture / Résistance à la traction-Module de rupture/ Zugfestigkeit-Bruchdehnung / Resistenza a trazione-Allungamento a rottura / Treksterkte -Rek na breuk / Odporność na ścieranie-Stopień uszkodzenia / Прочность на растяжение-Удлинение при разрыве	0.26%	EN ISO 527:1996
Resistencia a la tracción-Módulo de elasticidad / Tensile strength-Coefficient of elasticity / Résistance à la traction-Module d'élasticité / Zugfestigkeit-Elastizitätsmodul / Resistenza a trazione-Modulo elastico / Treksterkte -Elasticiteitscoëfficiënt / Odporność na ścieranie-Modul elastyczności / Прочность на растяжение-Модуль упругости	10330 MPa	EN ISO 527:1996
Resistencia al impacto (10mm de espesor) / Impact strenght (10 mm thickness) / Résistance à l'impact (10mm d'épaisseur) / Stofffestigkeit (10 mm Dicke) / Resistenza all'urto (10 mm di spessore) / Slagvastheid (10 mm dikte) / Odporność na uderzenie (10mm grubości) / Прочность на удар (10 мм толщины)	2 joule	UNI 10442:1995
Resistencia al calor seco / Dry heat resistance / Résistance à la chaleur sèche / Beständigkeit gegen trockene Wärme / Resistenza al calore secco / Droge lucht weerstand / Odporność na suche gorąco / Устойчивость к воздействию сухого тепла	5 to 120 °C	EN 12722:1997
Resistencia al calor húmedo / Wet heat resistance / Résistance à la chaleur humide / Beständigkeit gegen feuchte Wärme / Resistenza al calore umido / Vochtige warmte weerstand / Odporność na wilgotne gorąco / Устойчивость к воздействию влажного тепла	5 to 100 °C	EN 12721:1997
Resistencia al choque térmico / Thermal stress resistance / Résistance au choc thermique / Beständigkeit gegen Temperaturschwankungen / Resistenza agli sbalzi termici / Thermische belastingsweerstand / Odporność na szok termiczny / Устойчивость к тепловому удару	level 5	UNI 9429:1989



## CARACTERÍSTICAS TÉCNICAS TECHNICAL CHARACTERISTICS

CARACTÉRISTIQUES TECHNIQUES  
TECHNISCHE EIGENSCHAFTEN  
CARATTERISTICHE TECNICHE  
WŁAŚCIWOŚCI TECHNICZNE  
TECHNISCHE KENMERKEN  
ТЕХНИЧЕСКИЕ ХАРАКТЕРИСТИКИ

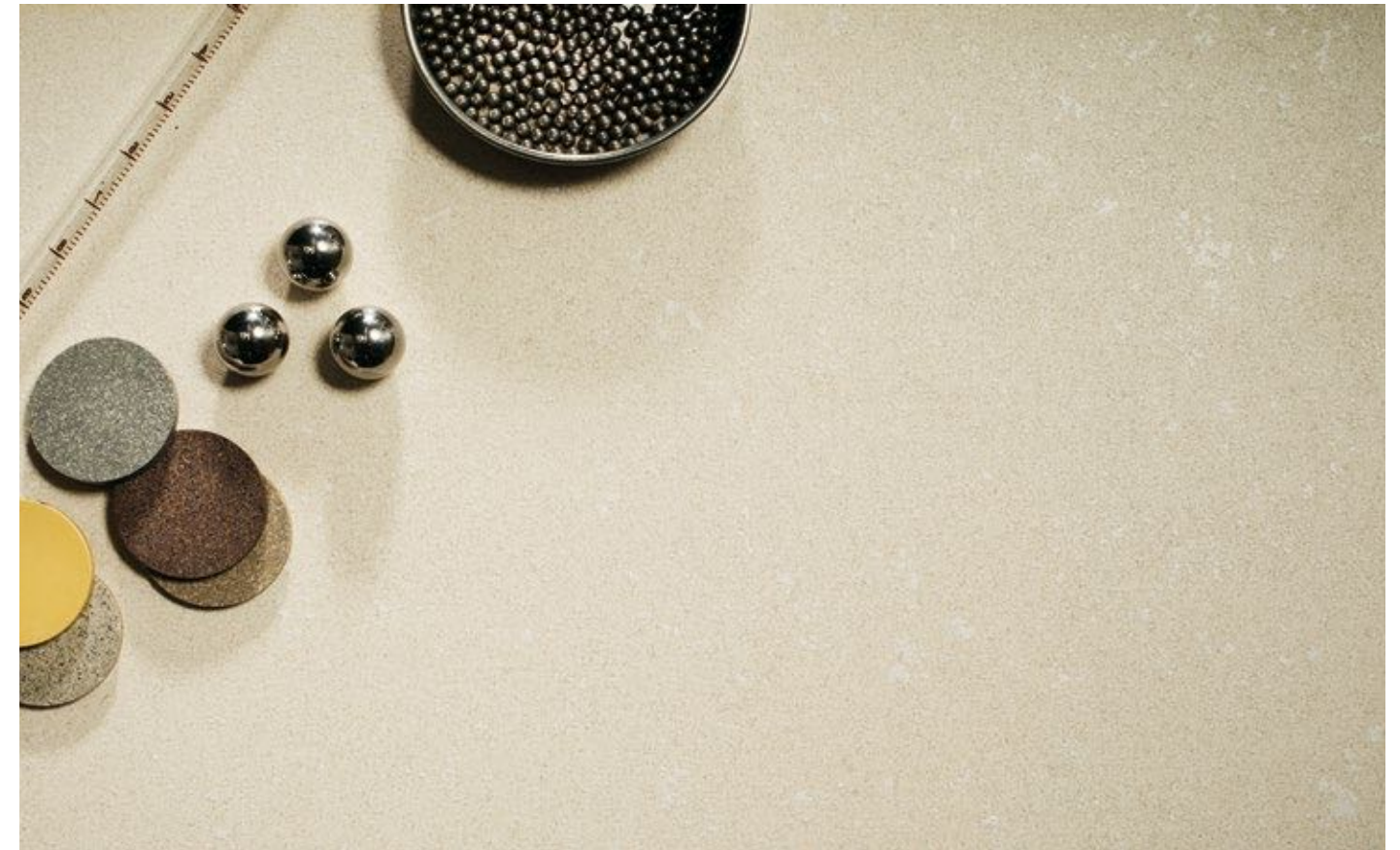

### **CERTIFICADOS**

CERTIFICATIONS / ZERTIFIKATE / CERTIFICATS / CERTIFICAZIONI /  
CERTYFIKATY / CERTIFICATIONS / СЕРТИФИКАТЫ

### **EJEMPLOS DE COLOCACIÓN**

TILE LAYOUT PATTERNS / EXEMPLES DE POSE / VERLEGUNGSBEISPIELE / ESEMPI DI POSA IN OPERA /  
PROPOZYCJA UŁOŻENIA PŁYTEK / LEGPATRONEN / ПРИМЕР УКЛАДКИ

### **PIEZAS ESPECIALES**

SPECIAL TILE PIECES / PIÈCES SPÉCIALES / FORMTEILE / PEZZI SPECIALI / PEZZI SPECIALI / ELEMENTY SPECJNE  
BIJZONDERE TEGELS / СПЕЦИАЛЬНЫЕ ИЗДЕЛИЯ

### **SIMBOLOGÍA**

SYMBOLS / SYMBOLES / SYMBOLE / SIMBOLOGIA/ PARAMETRY / SYMBOLEN / СИМВОЛЫ

### **PACKING LIST**

PACKAGING SPECIFICATIONS / SPÉCIFICATIONS D'EMBALLAGE / VERPACKUNGSDATEN / SPECIFICHE DELL'IMBALLAGGIO /  
SPECYFIKACJA PAKOWANIA / VERPAKKINGSGEGEVENS / ОПИСАНИЕ УПАКОВКИ

### **ÍNDICE DE PIEZAS**

PRODUCT INDEX / INDEX DES PIÈCES / ARTIKELVERZEICHNIS / INDICE DEI PEZZI / WYKAZ ELEMENTÓW /  
OVERZICHT VAN DE PRODUCTEN / УКАЗАТЕЛЬ ИЗДЕЛИЙ

CARACTERÍSTICAS TÉCNICAS

TECHNICAL CHARACTERISTICS / CARACTÉRISTIQUES TECHNIQUES / TECHNISCHE EIGENSCHAFTEN / CARATTERISTICHE TECNICHE / WŁAŚCIWOŚCI TECHNICZNE / TECHNISCHE KENMERKEN / ТЕХНИЧЕСКИЕ ХАРАКТЕРИСТИКИ

PORCELÁNICO PORCELAIN TILES														
SERIE SERIES	REFERENCIA REFERENCE	UNE-EN ISO 10545-3 AA*	UNE-EN ISO 10545-4 R-F*	UNE-EN ISO 10545-9 R-CH-T*	UNE-EN ISO 10545-11 R-C*	UNE-EN ISO 10545-14 M*	UNE-EN ISO 10545-13 A-L* A-P* A*/B*	UNE-EN ISO 10545-7 PEI*	UNE-EN ISO 10545-12 R-HE*	NORMA DIN 51 130	NORMA ASTM-C1028-96 FD FW	UNE-ENV 12633 /2003	NORMA DIN 51097	NORMA BS 7676 PTV WET 45
LORD	BLANCO, MARFIL	<0,3%	>45N/mm²	Resiste	Resiste	5	GA GA GLA	IV	Resiste	R-9	>0,6 >0,6	Class 1	A	
	ANTRACITA	<0,3%	>45N/mm²	Resiste	Resiste	5	GA GA GLA	IV	Resiste	R-9	>0,6 >0,6	Class 1	A	

PORCELÁNICO PORCELAIN TILES														
SERIE SERIES	REFERENCIA REFERENCE	UNE-EN ISO 10545-3 AA*	UNE-EN ISO 10545-4 R-F*	UNE-EN ISO 10545-9 R-CH-T*	UNE-EN ISO 10545-11 R-C*	UNE-EN ISO 10545-14 M*	UNE-EN ISO 10545-13 A-L* A-P* A*/B*	UNE-EN ISO 10545-7 PEI*	UNE-EN ISO 10545-12 R-HE*	NORMA DIN 51 130	NORMA ASTM-C1028-96 FD FW	UNE-ENV 12633 /2003	NORMA DIN 51097	NORMA BS 7676 PTV WET 45
MILAN	BLANCO, BEIGE, PERLA	<0,3%	>45N/mm²	Resiste	Resiste	5	GA GA GLA	IV	Resiste	R-9	>0,6 >0,6	Class 1	A	36+
	MARRÓN, AZUL, ANTRACITA	<0,3%	>45N/mm²	Resiste	Resiste	5	GA GA GLA	IV	Resiste	R-9	>0,6 >0,6	Class 1	A	36+

PORCELÁNICO TÉCNICO / TODO MASA PORCELAIN TILES / FULL BODY														
SERIE SERIES	REFERENCIA REFERENCE	UNE-EN ISO 10545-3 AA*	UNE-EN ISO 10545-4 R-F*	UNE-EN ISO 10545-9 R-CH-T*	UNE-EN ISO 10545-11 R-C*	UNE-EN ISO 10545-14 M*	UNE-EN ISO 10545-13 A-L* A-P* A*/B*	UNE-EN ISO 10545-7 PEI*	UNE-EN ISO 10545-12 R-HE*	NORMA DIN 51 130	NORMA ASTM-C1028-96 FD FW	UNE-ENV 12633 /2003	NORMA DIN 51097	NORMA BS 7676 PTV WET 45
ALPES	BLANCO, GRAFITO, NEGRO	<0,1%	>50N/mm²	Resiste	-	5	UA UA ULA	<150mm²	Resiste	R-10	>0,6 >0,6	Class 1	A	36+
ATACAMA	NEGRO, MARENGO, TAB, GRIS, BL, BGE	<0,1%	>50N/mm²	Resiste	-	5	UA UA ULA	<150mm²	Resiste	R-9	>0,6 >0,6	Class 1	A	-

PAVIMENTO WHITE BODY											
SERIE SERIES	REFERENCIA REFERENCE	UNE-EN ISO 10545-3 AA*	UNE-EN ISO 10545-4 R-F*	UNE-EN ISO 10545-9 R-CH-T*	UNE-EN ISO 10545-11 R-C*	UNE-EN ISO 10545-14 M*	UNE-EN ISO 10545-13			UNE-EN ISO 10545-7 PEI*	UNE-EN ISO 10545-12 R-HE*
							A-L*	A-P*	A*/B*		
BUSAN	BLANCO	<3%	>40N/mm <sup>2</sup>	Resiste	Resiste	5	GA	GA	GLA	IV	Resiste
JOLLY	TANGO, LAGO	<3%	>40N/mm <sup>2</sup>	Resiste	Resiste	5	GA	GA	GLA	II	Resiste
JOLLY	ROJO, NEGRO, ANTRACITA	<3%	>40N/mm <sup>2</sup>	Resiste	Resiste	5	GA	GA	GLA	III	Resiste
JOLLY	BLANCO, AZUL, PERLA, MARENGO, BEIGE, NUZZ	<3%	>40N/mm <sup>2</sup>	Resiste	Resiste	5	GA	GA	GLA	IV	Resiste
JOLLY	NARANJA, AMATIS, MARRÓN, OCRE, VERDE	<3%	>40N/mm <sup>2</sup>	Resiste	Resiste	5	GA	GA	GLA	IV	Resiste
JOLLY	PISTACHO, PRUSIA, GRIS, LIMA	<3%	>40N/mm <sup>2</sup>	Resiste	Resiste	5	GA	GA	GLA	IV	Resiste
KAZAN	GRIS, BEIGE	<3%	>40N/mm <sup>2</sup>	Resiste	Resiste	5	GA	GA	GLA	III	Resiste
TUTSI	BL, BGE, NAR, RJO, MARRÓN, GRIS, ANTRACITA	<3%	>40N/mm <sup>2</sup>	Resiste	Resiste	5	GA	GA	GLA	IV	Resiste
TURKANA	ANTRACITA, BEIGE, MARINO, BURDEOS	<3%	>40N/mm <sup>2</sup>	Resiste	Resiste	5	GA	GA	GLA	III	Resiste
TURKANA	AMARILLO, VERDE	<3%	>40N/mm <sup>2</sup>	Resiste	Resiste	5	GA	GA	GLA	IV	Resiste
TURKANA	BLANCO, NARANJA, LIMÓN, PISTACHO	<3%	>40N/mm <sup>2</sup>	Resiste	Resiste	5	GA	GA	GLA	IV	Resiste
ZERMATT	BLANCO, BEIGE	<3%	>40N/mm <sup>2</sup>	Resiste	Resiste	5	GA	GA	GLA	IV	Resiste

MOSAICO MOSAICS / MOSAIQUES / MOSAIKE / MOSAICI / MOZAIKI / ΜΟΣΑΙΚΑ	
<p>Este producto debido a su fabricación artesanal y al empleo de materiales especiales en su elaboración (piedras naturales, vidrio, metales, resinas, etc.) puede presentar variaciones de calibre, textura, diseño y tono. Estas variaciones dan al producto una personalidad propia y unas características irrepetibles. Por todo ello no se admitirán reclamaciones por estos motivos. Todas las series de Grespania Mosaico se pueden usar como pavimento y revestimiento, excepto la serie MUSA que debe utilizarse exclusivamente para revestimiento. Para otros usos rogamos consulte con nuestro departamento comercial. La serie MUSA no es resistente a los ataques químicos ácidos y alcalinos. Utilizar materiales adhesivos y de rejuntado neutros para la colocación, eliminando los restos antes del fraguado con esponja o trapo y empleando detergentes neutros, sin frotar.</p>	
<p>As a result of its craft manufacture and the use of special materials in its production (natural stone, glass, metals, resins, etc.), there may be variations in the gauge, texture, design and shade of this product. These variations give the product its own personality and uniqueness. For this reason, no claims will be accepted on the grounds of these variations. All the series of Grespania Mosaico can be used on floors and walls, except the MUSA series, which is to be used exclusively as a wall-covering. For other uses please contact our sales department. The MUSA collection is not resistant to acid nor alkaline. Use neutral adhesives and grouting materials when laying always removing the remains prior to cleaning with a sponge or flannel and using neutral detergents without scrubbing.</p>	
<p>En raison de sa fabrication artisanale et de l'emploi de matériaux spéciaux pour son élaboration (pierres naturelles, verre, métaux, résines, etc...), ce produit peut présenter des variations de calibre, texture, conception et tonalité. Ces variations donnent au produit une personnalité propre et des caractéristiques sans égales. C'est pourquoi aucune réclamation ne sera admise sur ces points. Toutes les séries de Mosaïque Grespania peuvent être employées comme pavement ou revêtement à l'exception de la série MUSA qui ne doit être utilisée que pour le revêtement. Pour d'autres usages, nous vous prions de consulter notre service commercial. La série MUSA ne résiste pas aux attaques chimiques acides ou alcalines. Utiliser une colle et des produits de jointoiement neutres pour la mise en oeuvre, en éliminant les résidus avant leur séchage, à l'aide d'une éponge ou d'un chiffon, et des détergents neutres, sans frotter.</p>	
<p>Aufgrund seiner handwerklichen Herstellung und der dabei verwendeten besonderen Materialien (Natursteine, Glas, Metalle, Harze usw.) kann das Produkt Abweichungen hinsichtlich der Maße, der Textur, des Designs und des Farbtons aufweisen. Diese Abweichungen verleihen dem Produkt seinen besonderen Charakter und machen es unverwechselbar und einzigartig, daher sind Reklamationen aus diesem Grund ausgeschlossen. Grundsätzlich können alle Mosaikfliesen-Serien von Grespania als Boden- oder Wandbelag verwendet werden, die Serie MUSA ist allerdings ausschließlich als Wandbelag geeignet. Für andere Anwendungszwecke wenden Sie sich bitte an unsere Verkaufsabteilung. Die Serie MUSA gegen säuren und alkalischen Chemikalienangriffen nicht widerstandsfähig. Bitte neutrale Kleb- und Verfugungsmaterialien verwenden, Restbestände vor der Reinigung mit einem Schwamm oder Tuch, ohne zu frotieren, mit neutralem Putzmittel entfernen.</p>	
<p>Data la produzione artigianale e l'impiego di materiali speciali nella lavorazione (pietre naturali, vetro, metalli, resine, ecc.), questo prodotto può presentare variazioni di calibro, texture, forma e tonalità. Queste variazioni conferiscono al prodotto una personalità unica e caratteristiche irripetibili. Non saranno perciò accolti i reclami riguardanti questi aspetti. Tutte le serie di mosaici di Grespania possono essere impiegate sia per pavimenti che per rivestimenti, eccetto la serie MUSA che è destinata esclusivamente al rivestimento. Per altri usi consultare il nostro ufficio commerciale. La serie Musa non è resistente agli attacchi chimici delle sostanze acide e alcaline. Utilizzare materiali adesivi e di posa neutri, eliminando l'eccedenza con una spugna o stoffa utilizzando detergenti neutri, senza strofinare.</p>	
<p>W przypadku tego produktu, ze względu na jego nieprzemysłowy sposób wykonania przy użyciu specjalnych materiałów (naturalnych kamieni, szkła, metali, żywicy, itp.) mogą występować różnice kalibru, tekstury, wzoru i tonacji. Różnice sprawiają, że produkt ten jest oryginalny i posiada niepowtarzalne cechy. Dlatego też nie będą przyjmowane reklamacje z powodu ich występowania. Wszystkie serie Mozaiki Grespania mogą być stosowane do wykładania zarówno ścian jak i podłóg, poza serią MUSA, którą należy stosować wyłącznie do wykładania ścian. W przypadku innych zastosowań, prosimy o kontakt z działem sprzedaży. Kolekcja / seria Musa nie jest odporna na kontakt z kwasami i zasadami. Zalecamy użycie neutralnych klejów i materiałów do układania spoin, usuwając resztki przed utwardzeniem gąbką lub szmatką i przy użyciu neutralnych detergentów, bez tarcia.</p>	
<p>Dit product kan dankzij de ambachtelijke productie en het gebruik van bijzondere materialen bij de vervaardiging ervan (natuursteen, glas, metalen, hars, enz.) variaties vertonen in grootte, textuur, ontwerp en tint. Deze variaties verlenen het product een eigen persoonlijkheid en unieke eigenschappen. En dit is de reden waarom er geen klachten voor deze motieven geaccepteerd worden. Alle Mozaïek series van Grespania kunnen gebruikt worden als vloer- en wandtegels, behalve de MUSA serie die exclusief als wandtegel gebruikt dient te worden. Voor overige toepassingen vragen wij u contact op te nemen met onze afdeling Verkoop. De Musa collectie is niet bestand tegen zuur of alkaline. Gebruik neutrale lijm- en voegproducten, verwijder tijdens verwerking altijd de resten vóór de schoonmaak met een spons en gebruik geen schuurmiddelen.</p>	
<p>Данная продукция была изготовлена с применением ручных методов, при этом были использованы особые материалы (натуральные камни, стекло, металлы, смолы и т. д.), поэтому ее размеры, текстура, дизайн и тон могут варьироваться. Это варьирование придает продукции собственную индивидуальность и неповторимые характеристики. Поэтому рекламации, мотивированные соответствующими причинами, не принимаются. Все серии мозаики Grespania могут использоваться для напольных покрытий и облицовки стен, кроме серии MUSA, которая должна применяться исключительно для облицовки стен. Перед использованием мозаики для иных целей, пожалуйста, проконсультируйтесь с нашим коммерческим отделом. Серия MUSA не устойчива к химическому воздействию кислот и щелочей. Используйте нейтральные клеи и затирочные материалы для укладки, удаляя остатки до того как они затвердеют мягкой губкой, используйте нейтральные моющие средства, не тереть.</p>	



SERIE SERIE	MEDIDA FORMAT	COLOR COULEUR	ACABADO FINITION	ENSAYO TEST
<b>LYON</b>	80X80 cm	TODOS/TOUS	RELIEVE	U4 P3 E3 C2
	80X80 cm	TODOS/TOUS	NATURAL	U4 P3 E3 C2
	60X60 cm	TODOS/TOUS	RELIEVE	U4 P4 + E3 C2
	60X60 cm	TODOS/TOUS	NATURAL	U4 P4 + E3 C2
	30X60 cm	TODOS/TOUS	RELIEVE	U4 P3 E3 C2
	30X60 cm	TODOS/TOUS	NATURAL	U4 P3 E3 C2
<b>LYON 12 MM</b>	30X60 cm	GRIS, MARFIL, GALENA	NATURAL	U4 P4 + E3 C2
	30X60 cm	GRIS, MARFIL, GALENA	RELIEVE	U4 P4 + E3 C2
<b>ALPES</b>	60X120/30X60 cm	TODOS/TOUS	TODOS/TOUS	U4 P3 E3 C2
	60X60 cm	TODOS/TOUS	TODOS/TOUS	U4 P4 + E3 C2
<b>ATACAMA</b>	60X60/45X45 cm	TODOS/TOUS	TODOS/TOUS	U4 P4 + E3 C2
	30X60 cm	TODOS/TOUS	TODOS/TOUS	U4 P3 E3 C2
<b>METEOR</b>	60X60 cm	TODOS/TOUS	NATURAL	U4 P4 + E3 C2
	60X60 cm	TODOS/TOUS	RELIEVE	U4 P4 + E3 C2
	60X60 cm	TODOS/TOUS	PULIDO	U3 P3 E3 C2
	30X60 cm	TODOS/TOUS	NATURAL	U4 P3 E3 C2
	30X60 cm	TODOS/TOUS	RELIEVE	U4 P3 E3 C2
	30X60 cm	TODOS/TOUS	PULIDO	U3 P3 E3 C2
	30X30 cm	TODOS/TOUS	NATURAL	U4 P4 + E3 C2
	30X30 cm	TODOS/TOUS	RELIEVE	U4 P4 + E3 C2
	30X30 cm	TODOS/TOUS	PULIDO	U3 P3 E3 C2
	<b>METEOR 15MM</b>	60X60 cm	BLANCO, GRIS, ANTRACITA, MARENGO	NATURAL

## UPEC

**Vous pourrez trouver toutes les nouvelles informations concernant les produits GRESPANIA certifiés par le CSTB, sur l'adresse suivante: <http://ow.ly/PSxsD>**

**La información actualizada de los productos de Grespania certificados por CSTB pueden encontrarse en la siguiente dirección: <http://ow.ly/PSxsD>**

The updated information on the CSTB certified Grespania products can be found following this link: <http://ow.ly/PSxsD>

SERIE SERIE	MEDIDA FORMAT	COLOR COULEUR	ACABADO FINITION	ENSAYO TEST
<b>STARK</b>	60X60 cm	TODOS/TOUS	NATURAL	U4 P4 + E3 C2
<b>STARK</b>	60X120 cm	TODOS/TOUS	NATURAL	U4 P3 E3 C2
<b>STARK 15MM</b>	60X60 cm	ANTRACITA, CEMENTO, GRIS, MARENGO, MARFIL, NEGRO, TAUPE	NATURAL	U4 P4S E3 C2

## CERTIFICADOS

CERTIFICATIONS / ZERTIFIKATE / CERTIFICATS / CERTIFICAZIONI  
CERTYFIKATY / CERTIFICATIONS / СЕРТИФИКАТЫ



### CERTIFICADO ISO 14001

Grespania cuenta con un **sistema de gestión ambiental** estructurado y certificado según directrices de la norma **ISO 14001**, sometido a auditorías externas realizadas anualmente, que permite identificar, evaluar y minimizar el impacto de la actividad productiva en el entorno.

Grespania has an **environmental management system** structured and certified strictly according to the guidelines set by **ISO 14001**. This system is subject to yearly external audits that detect, evaluate and minimise the effect the production activity may have on the environment.

Grespania applique un **système de gestion environnementale** structuré et certifié selon les directives de la norme **ISO 14001**, ce système étant soumis une fois par an à des audits externes ; il a pour objet d'identifier, d'évaluer et de minimiser l'impact des activités de production sur l'environnement.

Grespania dispone di un **sistema di gestione ambientale** - strutturato e certificato secondo le direttrici della norma **ISO 14001** e sottoposto ad audit esterni effettuati ogni anno - che consente di individuare, valutare e minimizzare l'impatto dell'attività produttiva sull'ambiente.

Grespania besitzt ein strukturiertes und nach den Richtlinien der Norm **ISO 14001** zertifiziertes Umweltmanagementsystem, das jedes Jahr externen Prüfungen unterzogen wird. Dadurch kann die Auswirkung der Produktionstätigkeit auf die Umwelt festgestellt, bewertet und auf ein Minimum reduziert werden.

Grespania posiada System Zarządzania Środowiskowego stworzony według normy **ISO 14001**, poddawany co roku procedurom audytu zewnętrznego, który pozwala na identyfikację, ocenę i minimalizację wpływu procesu produkcyjnego na otoczenie.

Grespania heeft een gestructureerd **milieubeheersysteem** gecertificeerd volgens richtlijnen van de norm **ISO 14001**, en het systeem is onderworpen aan jaarlijkse externe audits, waarmee de impact die de activiteit op de omgeving heeft kan worden geïdentificeerd, beoordeeld en minimaliseren.

Grespania имеет **систему экологического менеджмента** с хорошо разработанной структурой, сертифицированную в соответствии с директивами нормы **ISO 14001**. Эта система ежегодно подвергается внешнему аудиту, что позволяет определять, оценивать и сводить к минимуму воздействие производственной деятельности компании на окружающую среду.

### CERTIFICADO ISO 9001

Se tiene implantado un **sistema de calidad** acorde con las especificaciones establecidas en la norma internacional **UNE EN ISO 9001**, la cual establece los requisitos necesarios para garantizar la calidad en las etapas de diseño, desarrollo, producción y comercialización.

We have implemented a **Quality System** according to the **UNE EN ISO 9001** International regulation, which sets the requirements to guarantee quality during the stages of design, development, production and sales.

La société met en œuvre un **système de gestion de la qualité** conforme aux spécifications contenues dans la norme internationale **UNE EN ISO 9001**, qui définit les exigences à réunir pour garantir la qualité dans les phases de conception, de développement, de production et de commercialisation.

È stato instaurato un **sistema di qualità** in adempimento delle specifiche della norma internazionale **UNE EN ISO 9001**, che stabilisce i requisiti necessari per garantire la qualità nelle fasi di progettazione, sviluppo, produzione e commercializzazione.

Die Firma hat ein **Qualitätskontrollsystem** entsprechend den in der internationalen Norm **UNE EN ISO 9001** festgelegten Bestimmungen eingerichtet, wo die notwendigen Anforderungen angegeben werden, um die Qualität in den Design-, Entwicklungs-, Produktions- und Kommerzialisierungsphasen zu gewährleisten.

Wprowadziliśmy **system zarządzania jakością**, zgodnie z wytycznymi ustanowionymi przez międzynarodowy system **UNE EN ISO 9001**, który to ustanawia niezbędne do spełnienia wymogi mające na celu zapewnienie kontroli jakości na wszystkich etapach projektu, produkcji i komercjalizacji.

Het bedrijf heeft een **kwaliteitsmanagementsysteem** overeenkomstig de bepalingen neergelegd in de internationale norm **NE EN ISO 9001**, hierin zijn de noodzakelijke voorwaarden bepaald voor het garanderen van kwaliteit in de verschillende fase: ontwerp, ontwikkeling, productie en verkoop.

В компании внедрена система качества в соответствии со спецификациями, установленными международной нормой **UNE EN ISO 9001**, которая определяет требования, необходимые для гарантии качества на различных этапах создания дизайна, разработки, производства и коммерческой реализации.

### DECLARACIÓN DE CONTENIDO REICLADO DECLARATION OF RECYCLED CONTENT

23% en el porcelánico / 74,90% en revestimiento.  
23% in the case of porcelain tiles / 74,90% in the case of white body wall tiles.  
23% dans le cas du grès cérame / 74,90% dans celui des carreaux de mur.  
23% per il porcellanato / 74,90% per il rivestimento.

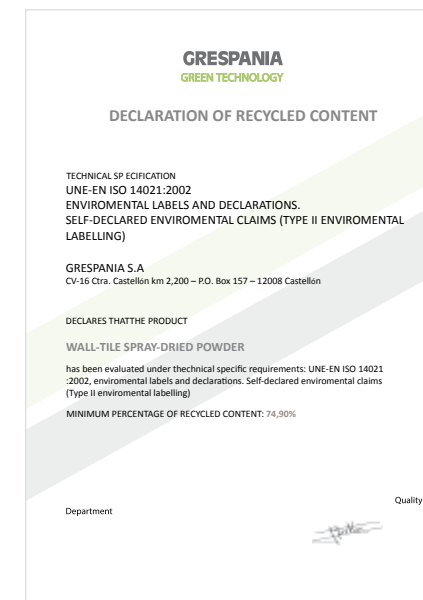

23% bei Feinsteinzeug / 74,90% bei Wandfliesen.  
23% w przypadku gresu / 74,90% w płytkach.  
23% voor porseleinen tegels / 74,90% voor bekleding  
23% в керамограните / 74,90% в плитке для облицовки стен



### DECLARACIÓN AMBIENTAL DE PRODUCTO TIPO III

Se tiene además una declaración ambiental de producto tipo III, según la norma ISO 14025, que mide el impacto medioambiental de la pieza cerámica a lo largo de todo su ciclo de vida, desde que las materias primas son extraídas de la tierra hasta que la pieza concluye su vida útil.

### ENVIRONMENTAL TYPE III PRODUCT CERTIFICATE

Furthermore, Grespania has an environmental type III product certificate also in accordance with ISO 14025. This certificate measures the environmental impact of the ceramic tile throughout its life span, from the moment raw materials are extracted, all the way during usage right up until the moment the ceramic tile is removed from its application and ceases to be used.

### DÉCLARATION ENVIRONNEMENTALE DE PRODUIT DE TYPE III

La société bénéficie en outre d'une déclaration environnementale de produit de type III selon la norme ISO 14025, qui mesure l'impact environnemental de la pièce en céramique tout au long du cycle de vie de cette dernière, de l'extraction matières premières de la terre à la fin du cycle de vie utile de la pièce.

### DICHIARAZIONE AMBIENTALE DEL PRODOTTO TIPO III

Inoltre, dispone della dichiarazione ambientale del prodotto tipo III, in base alla norma ISO 14025, che misura l'impatto ambientale del pezzo in ceramica nell'arco di tutto il suo ciclo di vita, cioè dall'estrazione delle materie prime dal suolo fino alla fine della vita utile del pezzo.

### UMWELTPRODUKTERKLÄRUNG TYP III

Außerdem hat die Firma eine Umweltprodukterklärung Typ III gemäß der Norm ISO 14025, mit der die Auswirkung der Keramikfliese auf die Umwelt im Verlauf ihres gesamten Bestehens gemessen wird, angefangen vom Abbau des dafür erforderlichen Rohstoffe aus der Erde bis hin zur Fliese nach Beendigung ihrer Lebensdauer.

### DEKLARACJĘ ŚRODOWISKOWĄ TYPU III

Wdrożyliśmy również dla naszych produktów deklarację środowiskową typu III, zgodnie ze standardem ISO 14025, która mierzy wpływ płytki ceramicznej na środowisko w trakcie całego jej cyklu życia, od momentu wydobycia surowca, aż do końca okresu jej użytkowania.

### MILIEUVERKLARING VAN HET PRODUCT

Tevens is het product gecertificeerd met een milieuverklaring type III volgens de ISO norm 14025, waarmee het milieueffect van de keramische tegel gedurende zijn volledige levensduur bepaald wordt, vanaf het moment waarop de grondstoffen gewonnen worden tot aan het moment dat het product verwijderd wordt van zijn toepassing aan het einde van de gebruiksfase.

### ЭКОЛОГИЧЕСКУЮ ДЕКЛАРАЦИЮ НА ПРОДУКЦИЮ ТИПА III

Кроме того, компания оформила экологическую декларацию на продукцию типа III, в соответствии с нормой ISO 14025. В этой декларации измеряется воздействие керамической плитки на окружающую среду в течение всего ее жизненного цикла, от выемки сырья из почвы до полного окончания срока службы изделия.

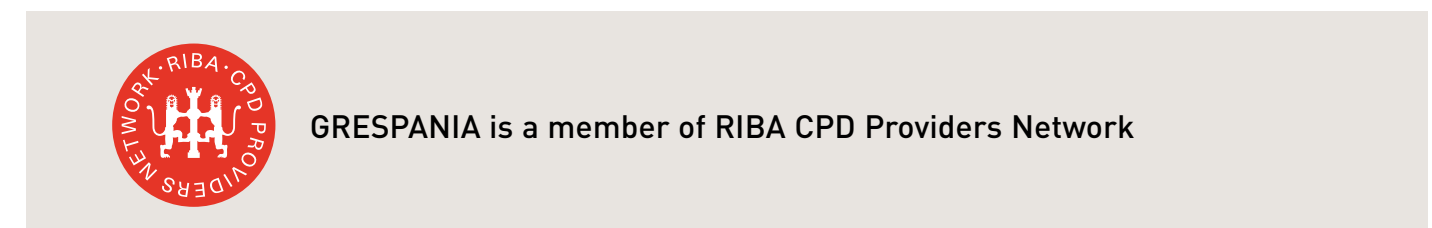







## PIEZAS ESPECIALES

SPECIAL TILE PIECES / PIÈCES SPÉCIALES / FORMTEILE / PEZZI SPECIALI / PEZZI SPECIALI / ELEMENTY SPECJALNE / BIJZONDERE TEGELS / СПЕЦИАЛЬНЫЕ ИЗДЕЛИЯ

### RODAPIÉ

Skirting tile / Plinthe / Fußleiste / Battiscopa / Cokolik / Plinten / Плинтус



### PELDAÑO PORCELÁNICO ESCUADRA

Square-edged porcelain tread / Marche en grès cérame à angle droit / Feinsteinzeug-Trittstufe, rechtwinklig / Gradino in porcellanato a squadra / Stopnica kant prosty gres porcelanowy / Porseleinen Traptredetegel Gekantrecht

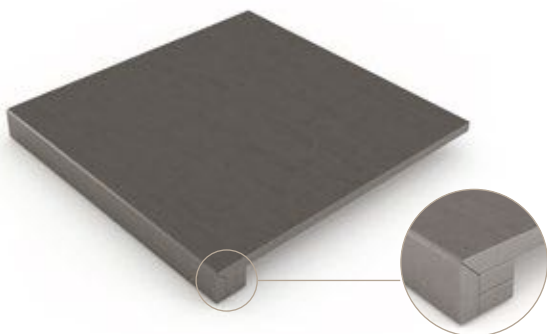

### PELDAÑO PORCELÁNICO ESCUADRA ANGULAR

Square-edged porcelain corner tread / Marche en grès cérame angulaire à angle droit / Feinsteinzeug-Ecktrittstufe, rechtwinklig / Gradino in porcellanato angolare a squadra / Stopnica narožna kant prosty gres porcelanowy / Porseleinen Hoekige Traptredetegel Gekantrecht / Ступенька из керамогранита угловая, с накладными валиками

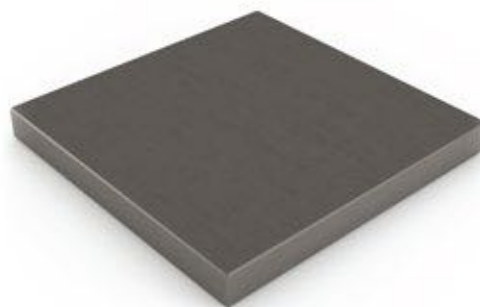

### PELDAÑO PORCELÁNICO ROMO HUELLA

Grooved porcelain step-tread / Marche en grès cérame rainurée et bout arrondi / Nez de marche en grès cérame avec courbe technique / Feinsteinzeug Stufenfliesen Mit Rille / Gradino in Porcellanico tecnico con pedata incisa / Stopnica ryflowana/ Porseleinen Gegroefd Tredevlak / Ступенька из технического керамогранита с неглубокими пропилами

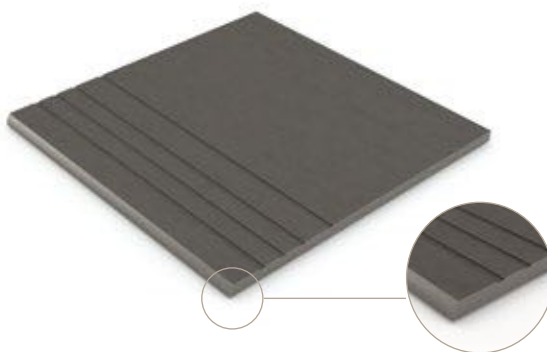

## SIMBOLOGÍA

SYMBOLS / SYMBOLES / SIMBOLE / SIMBOLOGIA / SIMBOLE / SYMBOLEN / УСЛОВНЫЕ ОБОЗНАЧЕНИЯ

	<b>porcelánico técnico todo masa</b> through-body porcelain tiles Grès cérame technique pleine masse durchgefärbtes Feinsteinzeug porcellanato tecnico tutta massa gres porcelanowy nieszkliwiony jednolity w masie full body tegels полнотельный технический керамогранит		<b>relieve</b> relief Reliefs Relieffliesen rilievo fakturove relief рельефная		<b>recomendable no colocar trabado a mitad de pieza</b> not to be laid with staggered tile joints Ne pas poser avec des joints décalés nicht mit versetzten Fugen verlegen si sconsiglia la posa in opera sfalsata nie zaleca się układania na zrąb er wordt aangeraden deze niet versprongen te leggen halverwege de tegel не рекомендуется укладка «вразбежку»
	<b>pasta coloreada</b> coloured-body Pâte colorée gefärbter Scherben pasta colorata kolorowe tworzywo płytki coloured body окрашенная глина		<b>liso</b> smooth Lisse glatt liscio gładkie vlak гладкая		<b>pieza especial</b> special tile pieces Pièces spéciales Formteil pezzo speciale element specjalny bijzondere tegel специальное изделие
	<b>antideslizante</b> anti-slip Antidérapant rutschhemmend antiscivolo antyślizgowe anti-slip противоскользкая		<b>espesor</b> thickness Épaisseur Dicke spessore grubość dikte толщина		<b>mallado</b> mesh-mounted Pièces sur filet auf Netz su rete mocowane na siatce net van gaas на сетке
	<b>brillo</b> glossy Brillant glänzend lucido potysk glans блестящая		<b>destonificado alto</b> Variety of shade: high Niveau de variation de tons : élevé Grad unterschiedlicher Farbnuancen: hoch variazione di tonalità: alta tonacja: duża różnica w tonacji tinten variatie: hoog степень вариативности тона: высокая		<b>decorado mallado</b> mesh-mounted décors Décors sur filet Dekorteile auf Netz decorato su rete wzór mocowany na siatce gedecoreerd met net van gaas с декором, на сетке
	<b>mate</b> matt Mat matt opaco matowe mat матовая		<b>destonificado medio</b> shade variation: medium Niveau de variation de tons : moyen Grad unterschiedlicher Farbnuancen: mittel variazione di tonalità: media tonacja: średnia różnica w tonacji tinten variatie: gemiddeld степень вариативности тона: средняя		
	<b>mate-brillo</b> matt-glossy Mat-Brillant matt-glänzend opaco-lucido matowe-potysk glans-mat матовая-блестящая		<b>destonificado suave</b> shade variation: low Niveau de variation de tons : faible Grad unterschiedlicher Farbnuancen: gering variazione di tonalità: leggera tonacja: niewielka różnica w tonacji tinten variatie: licht степень вариативности тона: низкая		
	<b>rectificado</b> rectified Rectifié kalibriert rettificato rektyfikowane gerectificeerd с выровненными краями (ректифицированный)	 <b>NORMA DIN 51097</b> <b>NORMA DIN 51130</b> <small>UNE-EN 12633/2003</small>			
	<b>no rectificado</b> non-rectified Non rectifié nicht kalibriert non rettificato nierektyfikowane niet gerectificeerd с невыровненными краями (не ректифицированный)		<b>junta mínima recomendada</b> minimum width of tile joint Largeur minimum de joint recommandée empfohlene Fugenmindestbreite fuga minima consigliata zalecana minimalna fuga aanbevolen minimum voeg рекомендуемый минимальный размер шва		





## ÍNDICE DE PIEZAS

PRODUCT INDEX / INDEX DES PIÈCES / ARTIKELVERZEICHNIS / INDICE DEI PEZZI / WYKAZ ELEMENTÓW /  
OVERZICHT VAN DE PRODUCTEN / УКАЗАТЕЛЬ ИЗДЕЛИЙ

# A

ABACO CALACATA <b>N</b>	224
ABACO PALADIO <b>N</b>	224
ABADIA	062
ADA	336
ADO	210
ALBORAN	220
ALISIO	312
ALMENA	084
ALPES <b>T</b>	030
ALSACIA	194, 217
ALTAI	066
ALUMINIO 100	195, 198, 200, 204, 221
AMADORA	170
AMAZONIA	068
AMBRAS 1, 2, 3	157
AMIENS	229
ANTARTIDA	246, 276
ANTICA	107
AQUA	340
ARVADA	126
ASPEN	126
ASTER	342
ASTORGA	256
ASTORGA 6	256
ATACAMA <b>T</b>	032
ATACAMA 20X60	322
ATELIER <b>N</b>	191
ATLAS	072
ATLAS 20MM	010
AUSTIN	198
AUSTIN 60X60	198
AUTOMNE	274
AVALON	076
AVALON 20MM	012
AVENUE	080

# B

BAGMATI	131
BAHAMAS	246
BAHIA	068, 160
BALEAR <b>N</b>	220
BALEAR 60	300

BÁLTICO <b>N</b>	220, 250
BALTICO 60 <b>N</b>	300
BARENTS 60 <b>N</b>	300
BARENTS 100 <b>N</b>	220
BARILOCHE	322
BASEL	194
BASEL 60X60	194
BASILEA	082
BASKET <b>N</b>	214, 294
BAU	250
BELLVER	084
BELUKHA	066
BEZIERS	228
BEZIERS 25	320
BILBAO	086
BOREAL	200, 217
BOREAS	308
BORNEO	306
BOSCO	288
BOSCO 6	288
BOSTON	090
BOSTON 25	314
BOSTON 90	254
BOTNIA	251
BOULDER	126
BRISA	308
BROADWAY 59, 119	145
BRON <b>T</b>	043
BYRON	266

# C

CALACATA	094
CALACATA ABUJARDADO	094
CALACATA 25	095
CALDERA <b>N</b> <b>T</b>	038
CAMBRIDGE	098
CANADA	316
CANAIMA	102
CANYON	176
CARPET 1, 2	176
CASTILLA	256
CAUCASO 20MM	014

CAVA	106
CEDAR	198
CEFIRO	312
CEILAN	306
CELOSIA CALACATA <b>N</b>	225
CENTER <b>T</b>	034
CEZANNE	282
CEZANNE 3	282
CHARTRES	229
CHICAGO	278
CHILOÉ <b>T</b>	032
CIBELES	272
CIBELES 1	272
CIMA	031
CINTIA	204
CIRCLE <b>N</b>	245
CIRENE	328
CITY	034
CLIO	314
CLUB	266
COLOSO 1, 2	159
COLUMBIA 25	318
COLUMBIA 45	282
COLUMBIA 60	282
COMO	298
COMOX	283
COREA	258
CRETA	286
CRETA 45X45	286
CRYSTAL	202
CUBANA	110

# D

DANBY CALACATA <b>N</b>	225
DANBY PALADIO <b>N</b>	225
DEDALO	128
DEGAS 1, 6	282, 288
DESSAU	250
DETROIT 1, 3	278
DICE <b>N</b>	244
DOCK	112
DOCK 20MM	016

DOTS	261
DURI <b>N</b>	292

# E

ECLAT	274
EDEN	288
EGEO 60 <b>N</b>	300
EGEO 100 <b>N</b>	220
ELIOT	268
ELISA	205
ESCORIAL <b>N</b>	116
ESTIVALE	275
ESTUCO	260
ESTUCO 60X60	260
ETHOSA <b>T</b>	277, 288

# F

FERRARA	094
FESTOS	287
FEZ 5	278
FINLANDIA	290
FONTENAY 119, 78	141
FORLI	094, 156
FRAGUA	180
FRASER	318
FREMONT	324
FUTURA	264

# G

GALA	204
GALA 60X60	206
GARDA	298
GEA	120
GEA 20MM	018
GLASS 4	290
GOBI	067
GOLDEN GATE	237
GRADINA <b>N</b>	232

GRID	214
GRUMANT <b>N</b>	221

# H

HABANA <b>N</b>	124
HARVARD	255
HELIOS	313
HEXAGON <b>N</b>	244
HEXAGONAL CALACATA	225
HEXAGONAL PALADIO	225
HOMESTONE	126
HOPEN <b>N</b>	220

# I

ICARIA	128
ICARO	287

# J

JACQUARD	228
JASPER	318
JAVA	306
JOLLY	184
JUNO	180
JUPITER <b>T</b>	046

# K

KANSAS	278
KAPLAN	254
KARA <b>N</b>	221
KATMANDU	130
KAVALA	278, 302
KIEL	290
KILIM	262
KILIM 60X60	261
KOTA 60 <b>N</b>	292
KOTA 100	210

# L

LABRADOR <b>N</b>	220
LANDART 60 <b>N</b>	294
LANDART 100	214
LAR	108
LAVICA <b>N</b> <b>T</b>	038
LAVICA 20MM <b>N</b> <b>T</b>	020
LEYRE 1, 2	170
LIEBANA	136, 140
LIEJA	132
LINE	034
LINE WHITE&CO	244
LOCARNO	258
LOGIA <b>N</b>	233
LOMBARDIA	298
LORD	266
LORD 60X60	267
LORENA <b>N</b>	194, 200, 220
LUCCA	094
LUMINOR <b>N</b>	300
LUXOR	216
LYON <b>T</b>	042
LYON 20MM <b>T</b>	022

# M

MADISON 1, 5	278
MAGISTER <b>N</b>	233
MAGMA <b>N</b> <b>T</b>	038
MANTO <b>N</b> <b>T</b>	038
MANTOVA	156
MAR	312
MARIANNE	206
MARITIMA 60 <b>N</b>	300
MARITIMA 100 <b>N</b>	220
MARMOREA CALACATA <b>N</b>	224
MARMOREA PALADIO <b>N</b>	224
MARTE <b>T</b>	046
MASALA	131
MATERIA	302

## ÍNDICE DE PIEZAS

PRODUCT INDEX / INDEX DES PIÈCES / ARTIKELVERZEICHNIS / INDICE DEI PEZZI / WYKAZ ELEMENTÓW /  
OVERZICHT VAN DE PRODUCTEN / УКАЗАТЕЛЬ ИЗДЕЛИЙ

MATRIX	Ⓟ	055
MELTEMI		312
MERLIN		202
METEOR	Ⓟ	046
MILAN		298
MILENIO		236
MINDANAO		306
MISTRAL		308
MODENA		094
MONASTERIO		062
MONTBLANC		258
MONTREAL	Ⓝ Ⓟ	050
MONTREAL 20MM	Ⓝ Ⓟ	024
MONZA		298
MOON		344
MORGANA		076
MURALLA		084
MUSA		330
MYSTIC		090

## N

NANCY		194
NARBONNE		229
NARBONNE 25		320
NARTEX		062
NARVAL		200
NEBRASKA		324
NEPAL		270
NEPAL 45X45		271, 307
NERVION		086
NEVADA		316
NEWPORT		314
NEWTON		314
NEXO	Ⓟ	054
NIJO		268
NIMES		228
NIMES 25		320
NOAM	Ⓟ	055

## O

OASIS		276
ONNE	Ⓝ	204
OSAKA		308
OTAWA		316

## P

PADOVA 1, 2, 3		156
PAINE	Ⓟ	032
PALACE AGATA		157
PALACE CALACATA		156
PALACE CARRARA		158
PALACE CREMA		158
PALACE DUNE		150
PALACE INDALO		158
PALACE MADRÁS		158
PALACE MERCURE	Ⓝ	136
PALACE NEW YORK	Ⓝ	144
PALACE PALISANDRO		148
PALACE PORT LAURENT	Ⓝ	140
PALACE RODAS		159
PALACE 90 CARRARA		272
PANDORA		202
PAONIA		126
PARK	Ⓟ	034
PATAGONIA		160
PATAGONIA 20MM		026
PAULAR 1, 2, 3		149, 150
PEDRIZA 1, 6		258, 276
PENELOPE		206
PLANET		346
PLATINIUM	Ⓝ	300
POBLET 2		162
PREMIUM	Ⓝ	245
PRINTEMPS		274
PULSO		176

## Q

QUELUZ		170
--------	--	-----

## R

RAVENNA		156
RECIFE		068, 160
RECTORIA		062
REIMS		228
REIMS 25		320
REIMS 30X30		320
RESERVA		108
REX 59, 119		148
ROBINE		229
RODANO	Ⓟ	043

## S

SABLIER		274
SAHEL		073
SAMI 6		282, 288
SANTA JUSTA		236
SAONA	Ⓟ	043
SAREK		276
SARLAT	Ⓝ	232
SATURNO		180
SAYANNES		067
SELENE		205, 211, 215, 221, 225, 229, 233
SHERWOOD		164
SHERPA		260
SIBERIA		290
SIDNEY	Ⓝ	168
SIGNIA		332
SINTRA		170
SIROCO		312
SKYLINE		172
SOFIA		206

SOLIDO	Ⓟ	055
SONORA		308
SPATULA	Ⓝ	190
SQUARE		294
STARK	Ⓟ	056
STEEL		221, 225
STRIPE	Ⓝ	124
SUECIA		276

## T

TALLIN		220, 250
TALOS		286
TAPIS		262
TEMPO		176
TERAI		270
TEXAS		198
TEXTURE	Ⓝ	188
THEO		210
TIROL	Ⓝ	244
TITAN	Ⓟ	058
TOPKAPI 1, 2, 3		157
TORELLO CALACATA		094
TORELLO PALACE CALACATA		156
TRAVIS		198
TRENTO		156
TUBQAL		073
TURKANA		185

## U

UNION	Ⓟ	054
URANO	Ⓝ	300

## V

VALENTINE		324
VALIRA		312
VALLE	Ⓟ	031
VELETA		312
VELIA		333
VERNON		318

VESLA		320
VESUBIO		247
VIEDMA		322
VIENTO		313
VOSGOS		194
VULCANIC	Ⓝ Ⓟ	038
VULCANO		180
VULCANO 100		236

## W

WABI CONCRETE	Ⓝ	240
WABI CONCRETE 60	Ⓝ	304
WABI FABRIC	Ⓝ	240
WABI FABRIC 60	Ⓝ	304
WABI SABI	Ⓝ	240, 304
WABI SABI 60X60	Ⓝ	241, 304
WABI WOOD	Ⓝ	240
WABI WOOD 60	Ⓝ	304
WALDORF		172
WALL		260
WALTER		215
WAVE		261
WHITE&CO	Ⓝ	244
WINDSOR		268

## Y

YAN	Ⓝ	211, 292
YOHO		282
YOHO 1, 6		282
YUSO 1, 2, 3	Ⓝ	140
YUSTE 1, 2, 3	Ⓝ	140, 148

## Z

ZAMBEZE	Ⓟ	052
ZEN		306, 308, 313
ZEUS		150
ZÓCALO CARRARA		272

Ⓝ  
nuevo  
new / nouveau / neu / nuovo / nowość / новое

Ⓟ  
porcelánico técnico todo masa  
through-body porcelain tiles  
Grès cérame technique pleine masse  
durchgefärbtes Feinsteinzeug  
porcelanato tecnico tutta massa  
gres porcelanowy nieszkliwiony jednolity w masie  
полнотельный технический керамогранит



GRESPANIA S.A.  
CV-16 Ctra. Castellón-Alcora Km.2,200  
P.O. BOX 157 / 12080 CASTELLÓN - SPAIN  
Tlf. +34 964 344 411 / Fax +34 964 344 401  
mail@grespania.com / www.grespania.com

---

GRESPANIA S.A dispone de un sistema de gestión certificado de acuerdo a las normas ISO 9001:2015 certificado N° 44 100 127697 e ISO 14001:2015 certificado N° 44 104 127697 en sus plantas de NULES y CASTELLON

---

GRESPANIA S.A. uses a managment system within its' facilities of Nules and Castellón in accordance with ISO 9001:2015 certificate N° 44 100 127697 and ISO 14001:2015 certificate N° 44 104 127697

*[www.grespania.com](http://www.grespania.com)*